

PMC-550D

Low-voltage Motor Protection and Control Device

User Manual

Version: 1.1

April 7, 2026





DANGER AND WARNING

This equipment can only be installed by professionals and the manufacturer will bear no responsibility for the failures caused by operations which do not conform to this manual.

Electric shock, Fire or Explosion

- Installation and maintenance of the meter should only be performed by the qualified persons.
- Before any operation on the equipment, voltage input and power supply should be isolated and the secondary windings of all the current transformers should be short-circuited.
- Please ensure that all incoming AC power and other power sources are turned OFF before any operation on the meter.
- All the mechanical components, doors and lids should be put in place before supplying power to the equipment.
- Please input rated voltage to the running equipment.

Failure to abide by the abovementioned instructions may result in severe injury.

This manual may not be reproduced in whole or in part by any means without the express written permission from CET Inc.

The information contained in this manual is believed to be accurate at the time of publication; however, CET Inc. assumes no responsibility for any errors which may appear here and reserves the right to make changes without notice. Please consult CET Inc. or your local representative for the latest product specifications.

Table of Contents

Chapter 1 Introduction	1
1.1 Overview	1
1.2 Features	1
1.3 PMC-550D's Application in Motor Control and Protection Circuit	4
1.4 Getting more information.....	4
Chapter 2 Installation	5
2.1 Relay Interface	5
2.2 HMI Display Module	6
2.3 Optional PMC-KT Interface	6
2.4 Optional PMC-KR Interface	7
2.5 Optional PMC-KI Interface	7
2.6 Current Transducers and Accessories	8
2.6.1 PMC-MTA Motor Current Transducers.....	8
2.6.2 MTA Cables	8
2.6.3 PMC-MIR Residual Current Transducers.....	8
2.7 Dimensions	9
2.7.1 Relay's Dimensions	9
2.7.2 HMI Module's Dimensions.....	9
2.7.3 Expansion Module's Dimensions	9
2.7.4 Terminal Dimensions	10
2.7.5 PMC-MTA Dimensions	10
2.7.6 PMC-MIR Dimensions	11
2.7.7 NTC Transducer Dimensions	13
2.8 Mounting	14
2.8.1 DIN-Rail Mounting for Relay and Expansion Modules.....	14
2.8.2 Panel Cutout Mounting for HMI Module.....	14
2.9 Connections with other modules.....	14
2.9.1 HMI Module Connection.....	15
2.9.2 Optional PMC-KT Module Connection	15
2.9.3 Optional PMC-KR Module Connection.....	16
2.10 PMC-MTA Wiring	16
2.11 Digital Output Wiring	17
2.12 Digital Input Wiring	18
2.13 Residual Current Input Wiring	18
2.14 Power Supply Wiring.....	18
2.15 Analog Output Wiring	18
2.16 Communications Wiring	18
2.16.1 RS-485 Wiring	19
2.16.2 Optional PROFIBUS Wiring.....	19
2.16.3 Ethernet Wiring	20
2.17 PTC/NTC Thermistor Connection	21
2.18 Ground Connection.....	21
2.19 Starter Wiring	21
2.19.1 Direct-On-Line Start	21
2.19.2 Reduce-voltage Start	21
2.19.3 Forward / Reverse Start.....	25
2.19.4 Two-Speed Start	26
Chapter 3 HMI Display Module	27
3.1 LED Indicators	27
3.2 Navigation Buttons	27
3.3 Control Buttons.....	27
3.4 HMI Display.....	28
3.4.1 Home Screen.....	28
3.4.2 Main Menu	29
3.4.3 Metering	29
3.4.4 DI/DO	30
3.4.5 View Parameters.....	30

3.4.6 Logs	31
3.4.7 Setup	32
3.4.8 Statistics	41
3.4.9 Maint.....	42
3.4.10 Info.....	44
Chapter 4 Applications	46
4.1 Digital Inputs	46
4.1.1 Configurations.....	46
4.1.2 DI Mode	46
4.2 Digital/Relay Outputs.....	47
4.2.1 DO Mode.....	47
4.2.2 Parameters.....	48
4.2.3 Non-fail-Safe Mode.....	48
4.3 Analog Output.....	48
4.4 Protection Overview	49
4.4.1 Motor States	49
4.4.2 Protection and Motor State.....	50
4.4.3 Protection Reset Mode.....	50
4.4.4 Mechanical Protection and Control.....	51
4.4.5 Electrical Fault Protection and Control.....	64
4.5 Local/Remote Control Mode	71
4.6 Undervoltage Restart.....	71
4.7 Motor AutoRestart.....	73
4.8 Device AutoRestart	73
4.9 Starter Function	74
4.10 Communication Test.....	75
4.11 Control Logic Test	75
4.12 Programmable Logic	75
4.13 Metering and Monitoring	75
4.13.1 Metering	76
4.13.2 Statistic	77
4.13.3 SOE (Sequence of Events).....	77
4.13.4 Protection Log.....	77
4.13.5 Start Report	77
4.13.6 Stop Report.....	78
4.13.7 Insulation Test.....	78
4.14 Self-check.....	78
4.15 Wiring Diagnosis	78
4.16 WFR (Waveform Recorder).....	79
4.17 Enhanced Power Supply	79
Chapter 5 Modbus Map.....	80
5.1 Real-time Relay Data.....	80
5.2 Statistic	82
5.3 Real-time Metering Data	83
5.4 Energy Measurement	83
5.5 Harmonic	83
5.6 Individual Harmonics	83
5.7 Device Setting	84
5.7.1 System Setting	84
5.7.2 Communication Setting	85
5.7.3 Protection Setting.....	86
5.7.4 Control Setting.....	88
5.7.5 DI Setting.....	89
5.7.6 DO Setting.....	90
5.7.7 AO Setting.....	90
5.7.8 Insulation Test Setting	90
5.7.9 Programmable Logic Setting.....	91
5.8 Data Logging	91
5.8.1 Protection Log.....	91

5.8.2 SOE Log	92
5.8.3 Start Report	93
5.8.4 Stop Report	93
5.8.5 Insulation Log.....	94
5.8.6 Waveform Log.....	94
5.9 Remote Control.....	95
5.10 Manual Operation.....	96
5.11 Time Registers.....	96
5.12 Device Information	96
Appendix A – SOE and Protection Log Classifications.....	98
Appendix B – Ordering Guide	103
Appendix C – Technical Specification	104
Appendix D – Accuracy Specification.....	106
Appendix E – Relay Elements Specifications	107
Appendix F – Standard of Compliance.....	109
Contact us.....	110

Chapter 1 Introduction

This manual explains how to use the PMC-550D Low-voltage Motor Protection and Control Device. Throughout the manual, the term “relay” generally refers to all models.

This chapter provides an overview of the PMC-550D and summarizes many of its key features.

1.1 Overview

The PMC-550D Low-voltage Motor Protection and Control Device seamlessly integrates motor protection, control, temperature monitoring, and insulation monitoring with a modular design. Featuring extensive I/O options, including 10xDI, 5xDO, 2xRS-485 port, 1xAnalog Output, 1xResidual Current Input, the relay offers flexibility and expandability. Its modular design allows easy expansion, connecting a standalone HMI module for monitoring and control, a PMC-KT module for additional 6xNTC, 2xDI and 1xDO for temperature monitoring and I/O control, and a PMC-KR module for ground fault insulation monitoring. The relay supports Modbus RTU, Modbus-TCP, PROFINET or PROFIBUS, with 10Base-T/100Base-TX Ethernet/PROFIBUS DP as an option. Equipped with a robust power supply, it ensures uninterrupted operation for 30 seconds during power interruption. These versatile functions make the relay suitable for diverse industrial needs.

1.2 Features

Functional Diagram

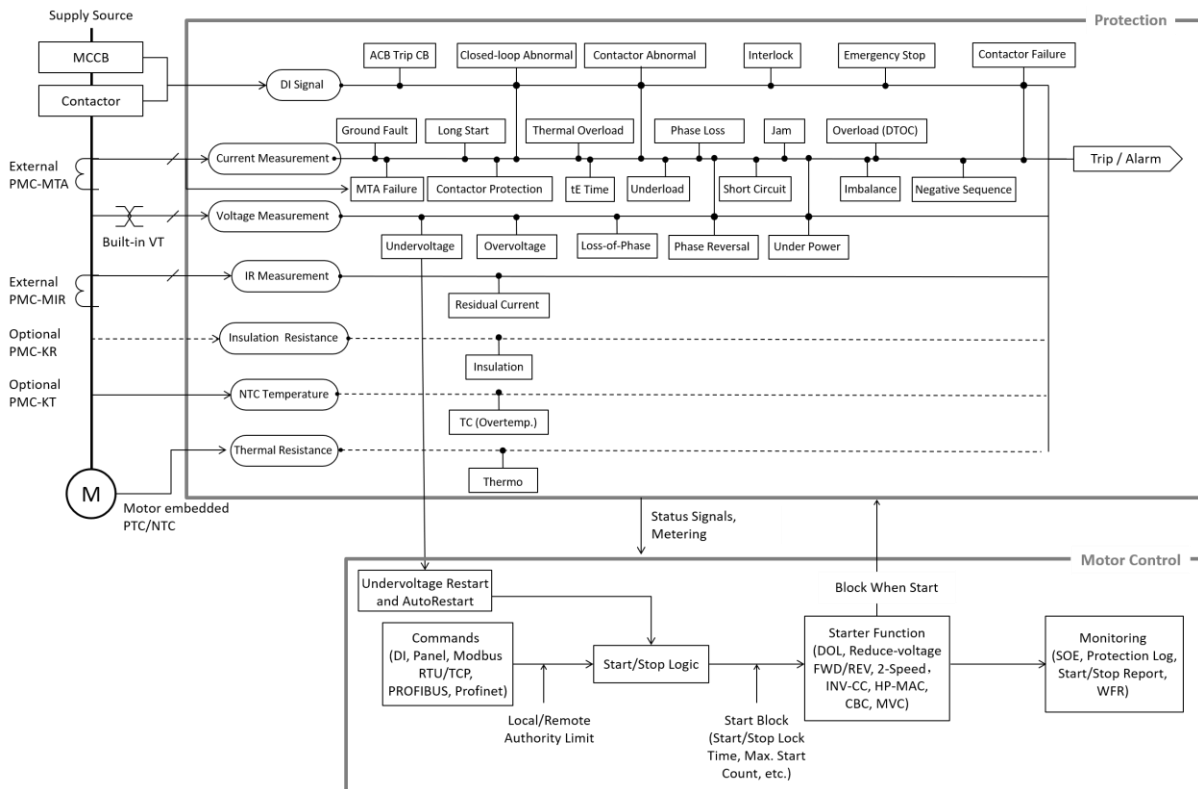

Figure 1-1 PMC-550D's Function Diagram

Motor Start

The PMC-550D offers generic motor control functions like Direct-On-Line, Forward-Reverse and Two-Speed Start control. It also provides advanced motor starting schemes to reduce high starting and surge currents to prevent troublesome voltage dips on the main supply and transient torque effects in mechanical systems. Use the PMC-550D to facilitate the motor ON/OFF sequence control.

Applications

- Direct-on-line Start
- Reduce-voltage Start (including Star-Delta Start, Auto-transformer Start and Resistance Start)
- Forward-Reverse
- Two-Speed

Motor Control

The PMC-550D is a microprocessor-based device that allows users to program and configure its operation through its HMI module to determine the actions to be done according to the situation.

- **Under-Voltage Restart.** This control mode is designed to restart a motor accordingly after a voltage dip. It may be either a quick restart, delay restart or stop, depending on the characteristic of the voltage dip.
- **AutoRestart.** This function determines the actions to be done after a machine stoppage due to a long Undervoltage period. It may be either a “restart” or “recover to the state before the stoppage.”
- **Local/Remote Control.** The PMC-550D allows the motor control to be done through the local panel or remote control.

Motor Protection

The electric motors have distinct electrical and mechanical operation limits. Exceeding these limits may lead to issues such as mechanical vibration, stoppage, thermal damage and ultimately, motor failure. These incidents may lead to raw material loss, equipment damage, non-quality production and production loss. These may also have a direct or indirect impact on human safety. The PMC-550D is not just designed to overcome these incidents and prevent their effects from causing damage to equipment. It is also intended to enhance the reliability of motors, conductors and critical components inside the PDU compartment, hence improving the entire system's reliability and productivity.

Protection Schemes

Electrical Fault Protection – Short Circuit, Ground Fault, Residual Current, LOP, Negative Sequence, MTA Failure, Insulation Resistance, Thermo (PTC or NTC), Overvoltage, Undervoltage, Imbalance, Phase Reversal.

Mechanical Protection – Jam, Long Start, Thermal Overload, Overload, Under Power, Interlock, tE Time, Closed-loop Abnormal, Thermo, Block When Start.

Metering and Monitoring

Fundamental Metering

- Line Voltage (UAB, UBC, UCA) and Current (IA, IB, IC) per phase and average
- Phase Angle
- IA/Ie* ratio (%), IB/Ie* ratio (%), IC/Ie* ratio (%) and Iavg/Ie* ratio (%)
- I1 (Positive Sequence), I2 (Negative Sequence) and Current Unbalance (%)
- 3I0 (calculated neutral Current) or optional IN (measured neutral Current)
- Total kW, kvar, kVA and PF
- Cooling Time (s) and Heat Capacity (%)
- Thermal Resistance (Ω)
- IR (Residual Current)
- System Frequency

RMS Metering

- Line Voltage (Uab, Ubc, Uca) and Current (Ia, Ib, Ic) per phase and average
- Phase Angle
- Ia/Ie ratio (%), Ib/Ie ratio (%), Ic/Ie ratio (%)
- Total kW, kvar, kVA and PF
- Total kWh Import/Export and Total kvarh Import/Export
- Optional TC1 to TC6 ($^{\circ}\text{C}$) if PMC-KT is equipped

Harmonic Metering

- U and I THD, TOHD and TEHD
- U and I Individual Harmonics from 2nd to 31st
- Latest motor operating statistics including Trip Current, Trip Times, Start Current, Start Time, Start Counter, Running Time, and Stop Time.

Motor Monitoring and Statistics

- 64 time-stamped logs recording DI/DO status changes, Diagnostic logs and Maintenance events
- 64 time-stamped protection logs recording active protection events with characteristic values
- Start Report stores the latest 64 motor start logs recording Start Control Source, Maximum Start Current, Minimum Start Voltage, Start Time, Time Stamp and Start Result
- Stop Report stores the latest 64 motor stop logs recording Stop Control Source, IA, IB, IC and Timestamp
- Waveform Recorder triggered by motor start or protection operated stores max. 16 logs recording of UAB, UBC, UCA, IA, IB, IC and IN

Insulation Monitoring

- Monitoring insulation resistance against the ground for de-energized motor or active conductor
- Superimposing a measuring voltage @ 500Vdc or 1000Vdc according to the system voltage
- Recording up to 500 insulation test results

Commission Test

- Communication Test by synchronizing the sample data to the workstation
- Control Logic Test for the relay's DI, DO and Protection Logic without interruption to the running motor

Programmable Logic

- Function Block Diagram (FBD) programming language compliant with IEC 61131-3
- Create Logic control equation with a drag-and-drop text editor via PMC-Designer

Inputs & Outputs

Digital Input

- Standard 10 channels, either externally wetted @ 220VAC/DC or internally wetted @ 24VDC based on the model option selected
- Optional 2 additional channels if PMC-KT module is equipped, dry contact, with 24VDC internally wetted
- Status Input or Control Input

Digital Output

- Standard 5 channels
- Optional one additional channel Form C contact output if the PMC-KT module is equipped
- Control and Status Indication

Analog Output

- 4-20 mA programmable analog output to display the proportional DC signal on an external analog meter or DCS system
- Selectable analog quantity such as 3-phase Current, Total kW, IR and 3I0

Optional NTC Input

- 6 channels NTC Thermistor Input via PMC-KT module for critical components, such as switches and contactors inside PDU compartment for long-term operation.

Communications Options

- Standard optically isolated 2xRS-485 port
- Optional 1xPROFIBUS DP port via either DB9 terminal or 3 position terminal block and 1xRS-485 port (Modbus RTU)
- Optional 1xPROFIBUS DP port either via DB9 terminal or 3 position terminal block and 1xRS-485 port (either Modbus RTU or PROFIBUS DP)
- Optional 2x10Base-T/100Base-TX Ethernet port (supporting Modbus TCP and SNTP) and 1xRS-485 port
- Optional 2xPROFINET over Ethernet Port + 1xRS-485 port

System Integration

- The PMC-550D is supported by CET's PMC-EasyConfig. In addition, it can be easily integrated into other 3rd party Automation or SCADA system because of its multiple communication ports supporting Modbus RTU/TCP and PROFIBUS DP protocol.

1.3 PMC-550D's Application in Motor Control and Protection Circuit

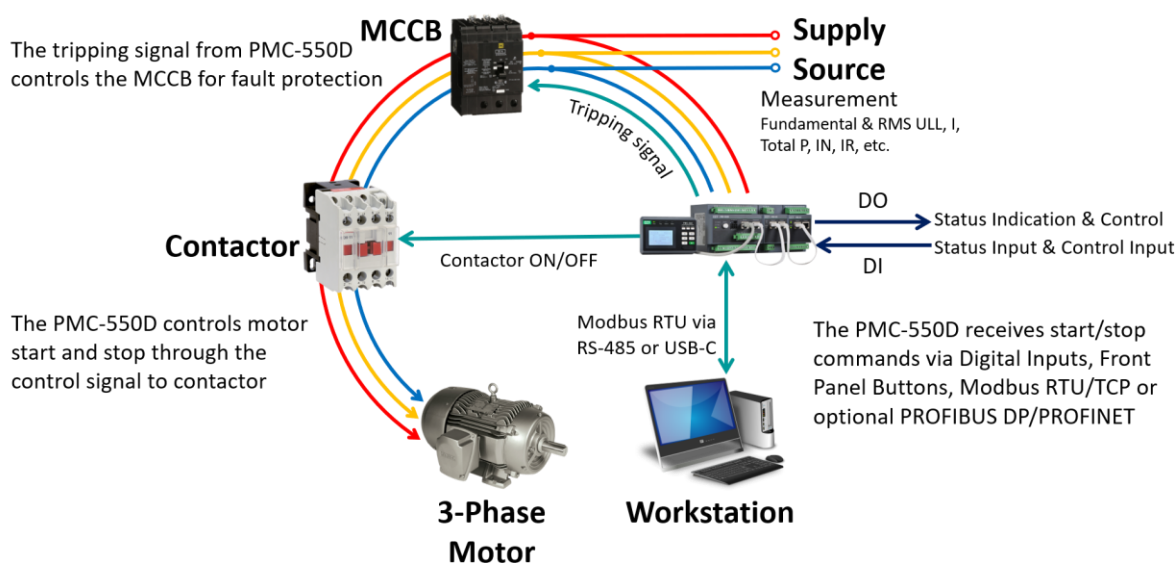

Figure 1-2 PMC-550D's Application in Motor Control and Protection Circuit

1.4 Getting more information

Additional information is available from CET via the following sources:

- Visit www.cet-global.com
- Contact your local representative

Contact CET directly via email at support@cet-global.com

Chapter 2 Installation

2.1 Relay Interface

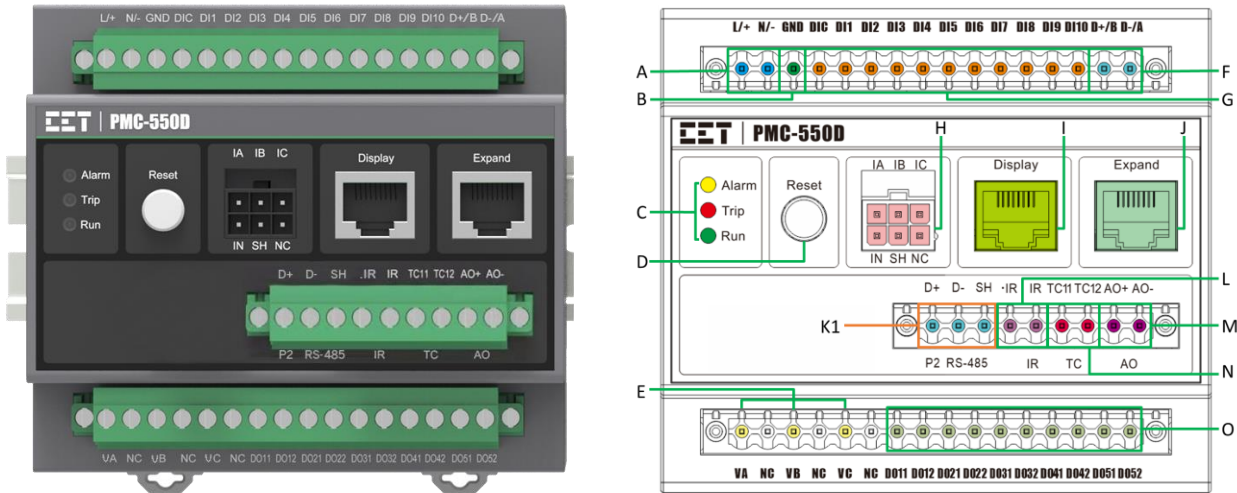

Figure 2-1 Panel View and Terminals Diagram for PMC-550D with 2xRS-485

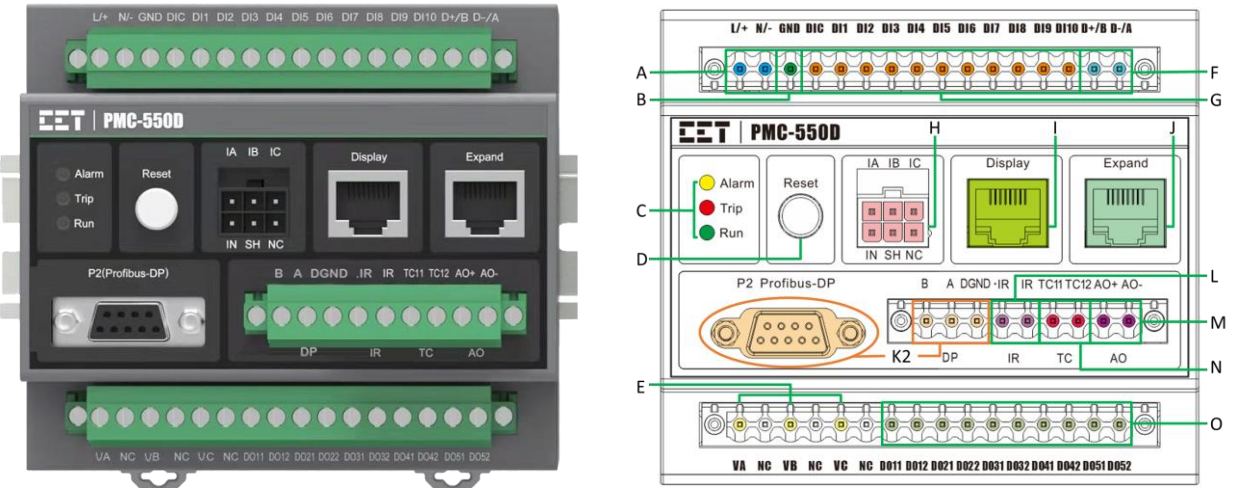

Figure 2-2 Panel View and Terminals Diagram for PMC-550D with 1xPROFIBUS DP+1xRS-485 (or 2xPROFIBUS DP)

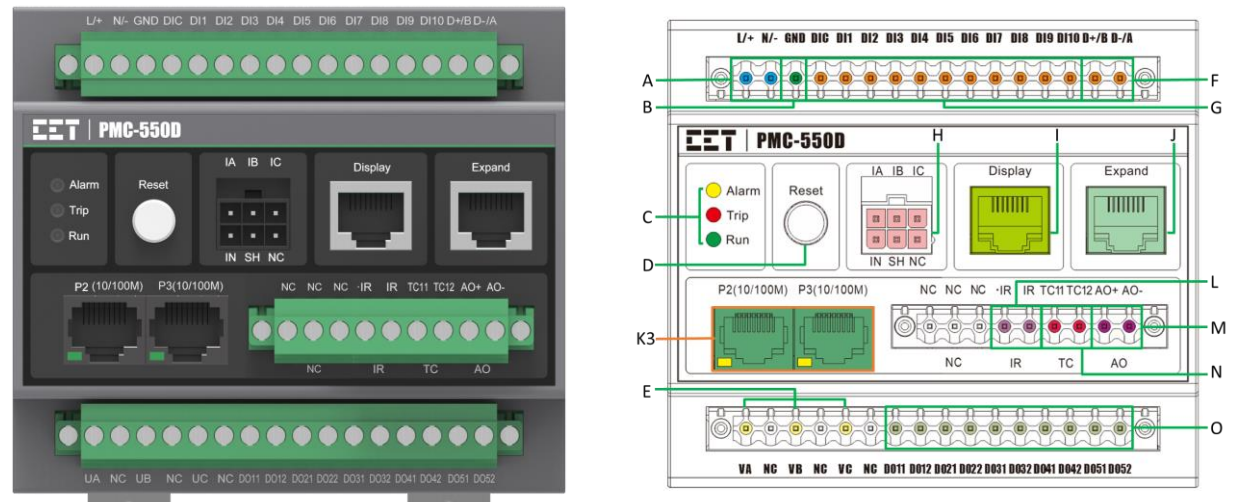

Figure 2-3 Panel View and Terminals Diagram for PMC-550D with 2x10Base-T/100Base-TX Ethernet Port

The figures above show the relay's connections to cover all order options. The interface components are labelled A to O, as shown in the figures above.

Region	Labels	Descriptions
A	L/+, N/-	Power Supply
B	GND	Chassis Ground
C	Alarm / Trip / Run	LED Indicators
D	Reset	Reset Button
E	VA, VB, VC	Voltage Inputs
F	D+/B, D-/A	RS-485 Port (support PROFIBUS DP for Communication option "D")
G	DIC, DI1 to DI10	Digital Inputs
H	IA, IB, IC, IN, SH	Current Inputs
I	Display	RJ45 connector for remote Display Module connection (PoE)
J	Expand	RJ45 connector for Expansion Module PMC-KT (PoE) or PMC-KR (External power source)
K1	D+, D- P2 RS-485	RS-485 Port
K2	P2 (Profibus DP), DP	PROFIBUS DP (either DB9 terminal or 3 position terminal block)
K3	P2 (10/100M) P3 (10/100M)	10Base-T/100Base-TX Ethernet Ports
L	·IR, IR	Residual Current Input
M	AO+, AO-	Analog Output
N	TC11, TC12	Temperature Input (PTC or NTC)
O	DO11, DO12, DO21, DO22, DO31, DO32, DO41, DO42, DO51, DO52	Digital Outputs

Table 2-1 Relay's Terminal Descriptions

2.2 HMI Display Module

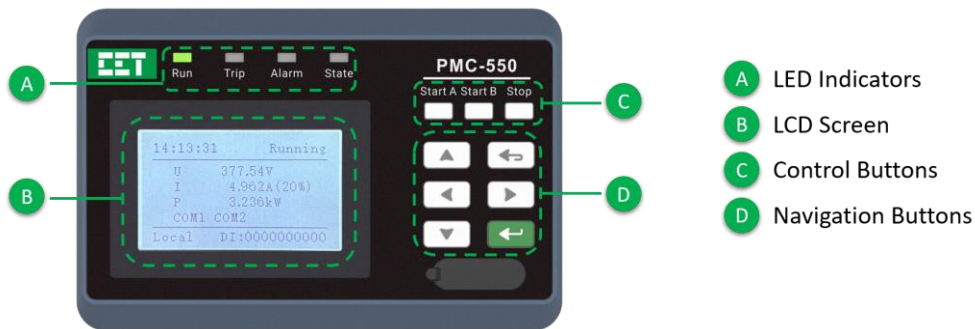

Figure 2-4 HMI Display Module

2.3 Optional PMC-KT Interface

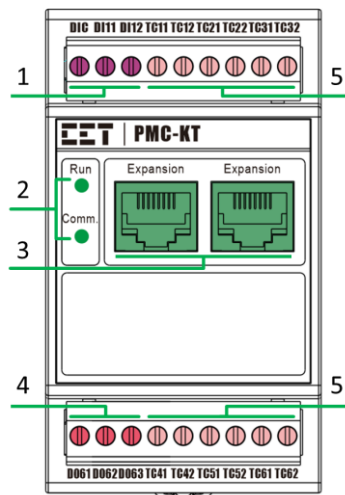

Figure 2-5 PMC-KT Front View and Terminals Diagram

Region	Labels	Descriptions
1	DIC, DI11, DI12	Digital Inputs
2	Run/Comm.	LED Indicators

3	DO61, DO62, DO63	Form C Mechanical Relay
4	Expansion	Ports for PMC-550 Relay and PMC-KR connection
5	TC11, TC12, TC21, TC22, TC31, TC32 TC41, TC42, TC51, TC52, TC61, TC62	Temperature Inputs (NTC)

Table 2-2 PMC-KT Terminals Descriptions

2.4 Optional PMC-KR Interface

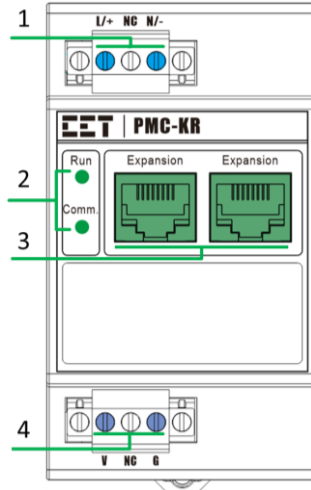

Figure 2-6 PMC-KR Front View and Terminals Diagram

Region	Labels	Descriptions
1	L/+, N/-	Power Supply
2	Run/Comm.	LED Indicators
3	Expansion	Ports for PMC-550 Relay and PMC-KT connection
4	V, G	DC Voltage Output

Table 2-3 PMC-KR Terminals Descriptions

2.5 Optional PMC-KI Interface



Figure 2-7 Optional PMC-KI Front View and Terminals Diagram

Labels	Descriptions
1, 3 (No polarity)	Voltage Input Channel #1
2, 4 (No polarity)	Voltage Input Channel #2
5 (+), 7 (-)	Output Channel #1
6 (+), 8 (-)	Output Channel #2

Table 2-4 PMC-KI Terminals Descriptions

2.6 Current Transducers and Accessories

2.6.1 PMC-MTA Motor Current Transducers



No.	Models	No.	Models
1	PMC-MTA-1A (1x3-phase)	5	PMC-MTA-100A (1x3-phase)
2	PMC-MTA-400A-T (3x1-phase)	6	PMC-MTA-800A-T (3x1-phase)
3	PMC-MTA-5A (1x3-phase)	7	PMC-MTA-300A (1x3-phase)
4	PMC-MTA-25A (1x3-phase)		

Figure 2-8 PMC-MTA Motor Current Transducers Appearance

2.6.2 MTA Cables

Cable length: 2m



3-P MTA Special Cable

(Cable for connecting ONE molded case 3-P CT)

Cable length: 2m



1-P MTA Special Cable

(Cable for connecting THREE individual 1-P CTs)

Figure 2-9 MTA Cable with Pluggable Connector

2.6.3 PMC-MIR Residual Current Transducers



No.	Models	No.	Models
1	PMC-MIR-35	4	PMC-MIR-50
2	PMC-MIR-120	5	PMC-MIR-265*103
3	PMC-MIR-75		

Figure 2-10 PMC-MIR Residual Current Transducers Appearance

2.7 Dimensions

2.7.1 Relay's Dimensions

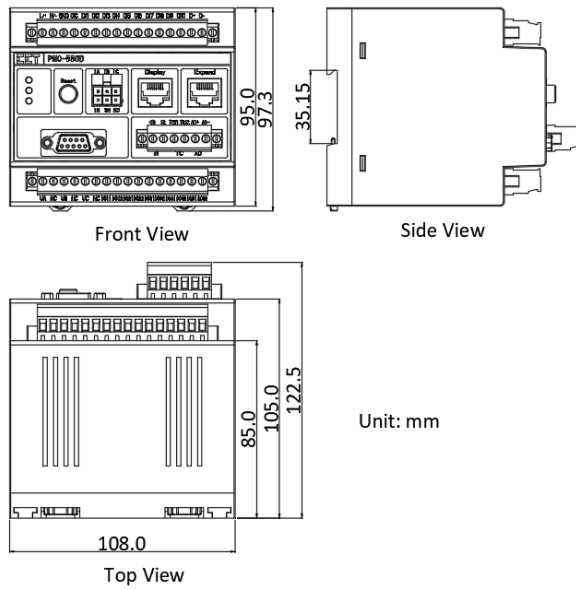

Figure 2-11 Relay's Dimensions

2.7.2 HMI Module's Dimensions

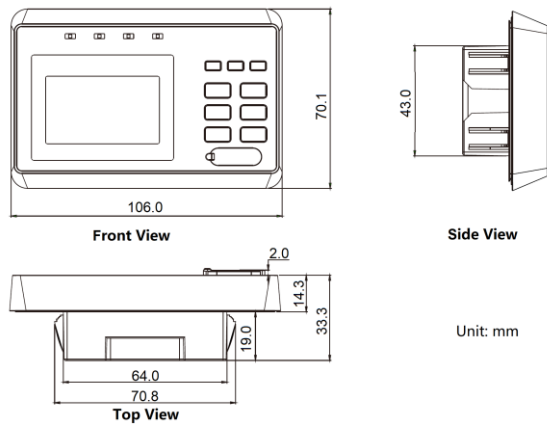

Figure 2-12 HMI Module's Dimensions

2.7.3 Expansion Module's Dimensions

The PMC-KT and PMC-KR expansion modules for the PMC-550D have the exact dimensions.

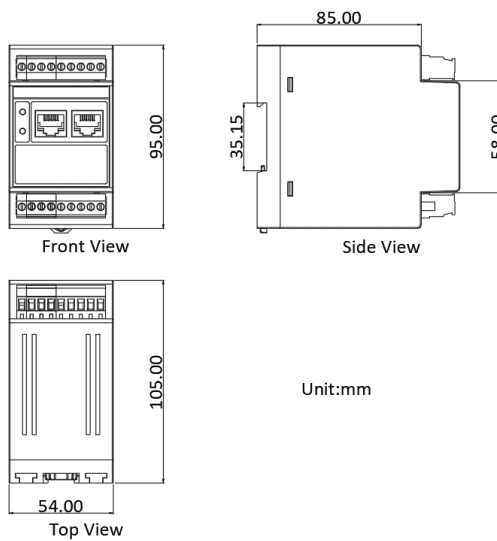

Figure 2-13 Expansion Module's Dimensions

2.7.4 Terminal Dimensions

Terminal	Terminal Dimensions	Wire Size	Max. Torque
Power Supply	□ 2.6mm x 3.2mm	0.2mm ² – 3.5mm ² (12-26AWG)	0.49N.m / 5 kgf.cm / M3 / 4.34 lb-in
Ground			
Digital Input			
Digital Output			
RS-485			
Current Input			
Voltage Input			
Analog Output			
IR Input			
Temperature Input			
V, G Output			

Table 2-5 Terminal Dimensions

2.7.5 PMC-MTA Dimensions

2.7.5.1 PMC-MTA-1A / PMC-MTA-5A

Unit: mm

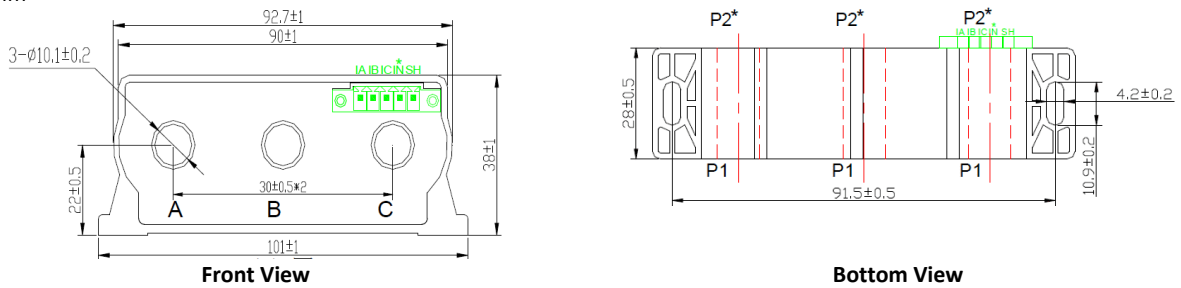

Figure 2-14 PMC-MTA-1A / PMC-MTA-5A Dimensions

2.7.5.2 PMC-MTA-25A

Unit: mm

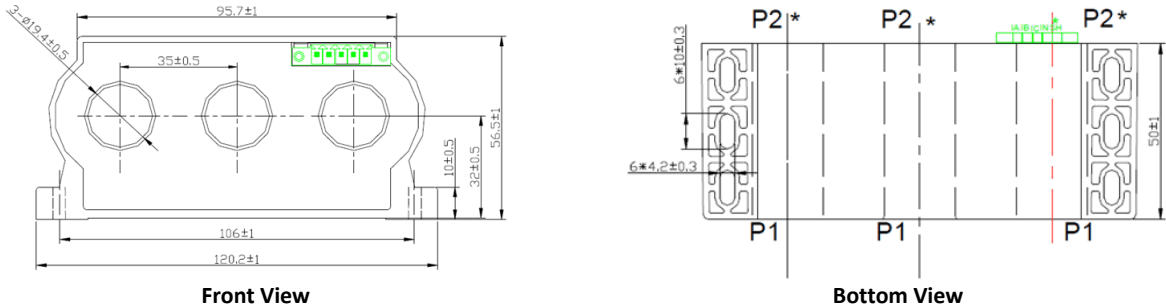

Figure 2-15 PMC-MTA-25A Dimensions

2.7.5.3 PMC-MTA-100A / PMC-MTA-300A

Unit: mm

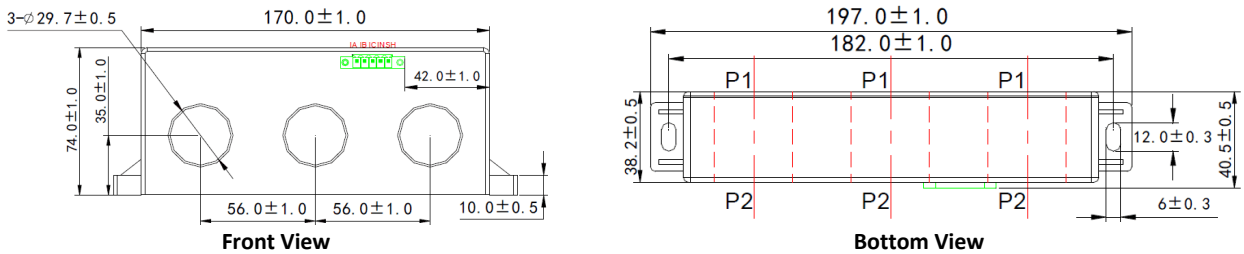

Figure 2-16 PMC-MTA-100A / PMC-MTA-300A Dimensions

2.7.5.4 PMC-MTA-400A-T

Unit: mm

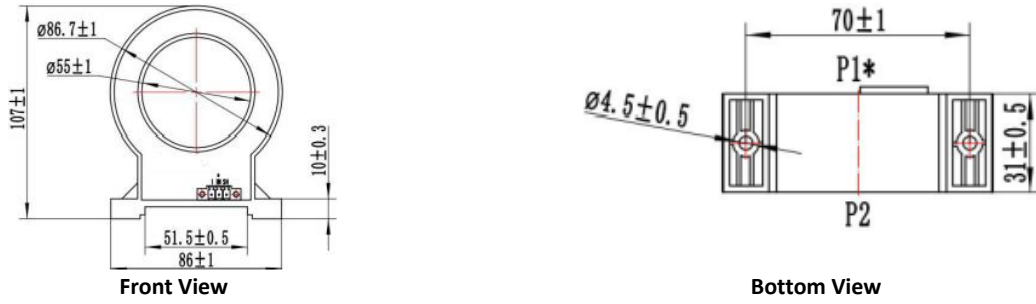

Figure 2-17 PMC-MTA-400A-T Dimensions

2.7.5.5 PMC-MTA-800A-T

Unit: mm

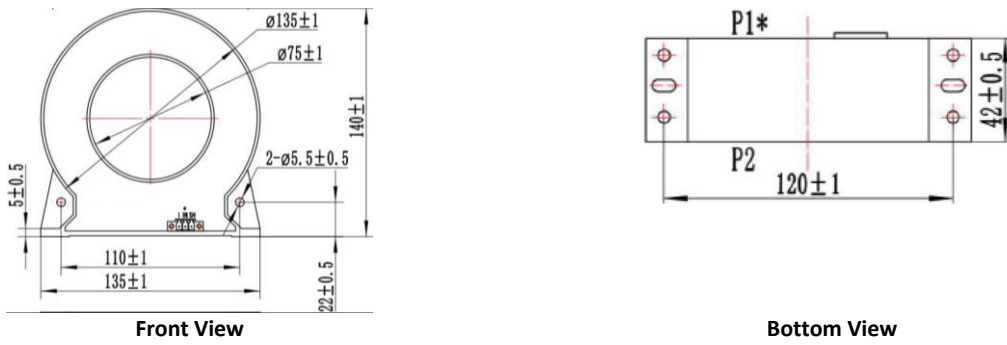

Figure 2-18 PMC-MTA-800A-T Dimensions

2.7.6 PMC-MIR Dimensions

2.7.6.1 PMC-MIR-35

Unit: mm

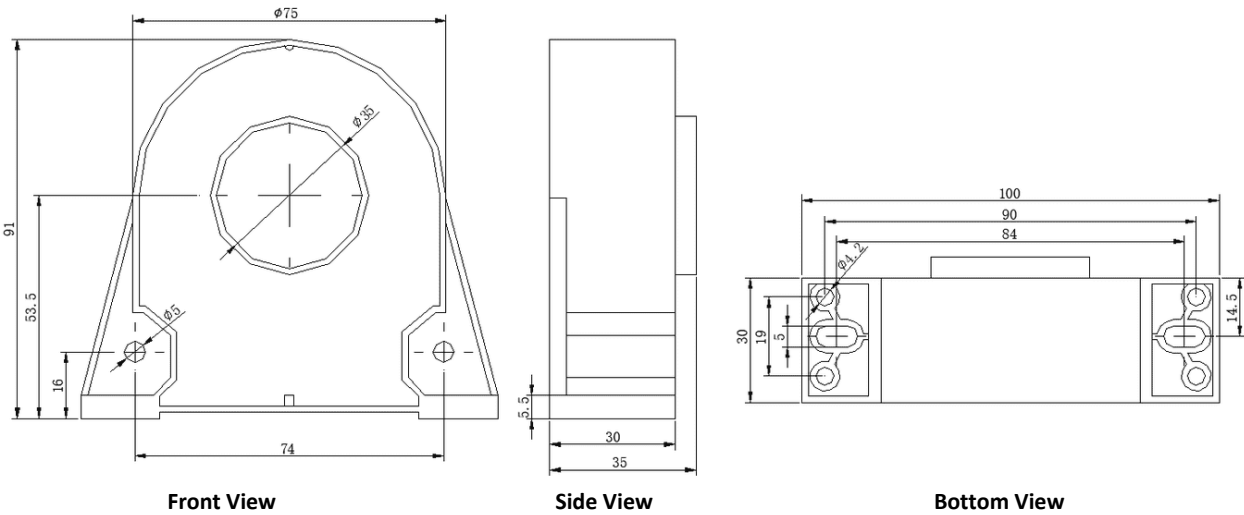

Figure 2-19 PMC-MIR-35 Dimensions

2.7.6.2 PMC-MIR-50

Unit: mm

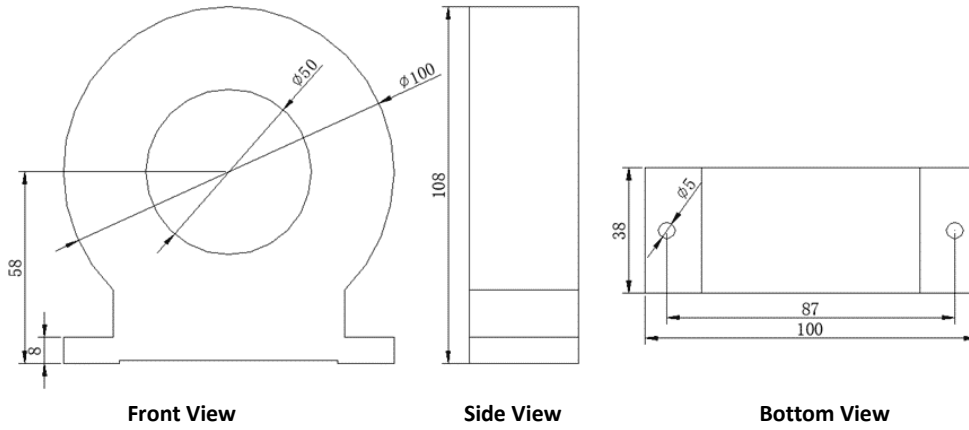

Figure 2-20 PMC-MIR-50 Dimensions

2.7.6.3 PMC-MIR-75

Unit: mm

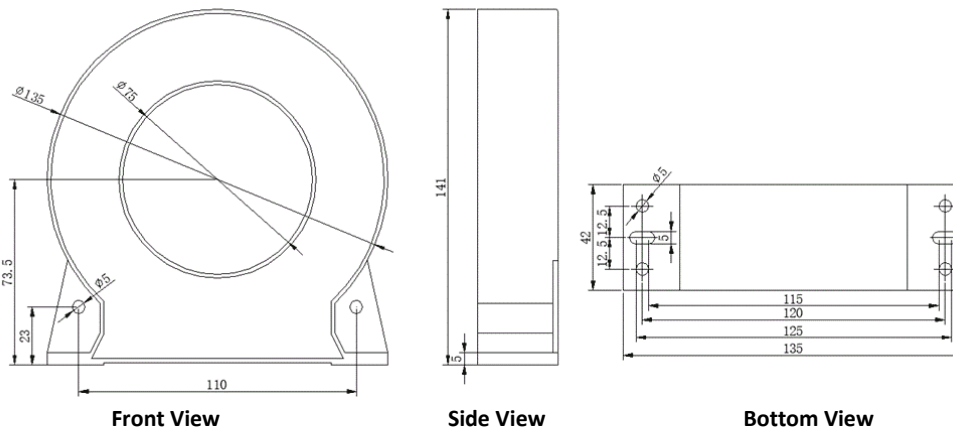

Figure 2-21 PMC-MIR-75 Dimensions

2.7.6.4 PMC-MIR-120

Unit: mm

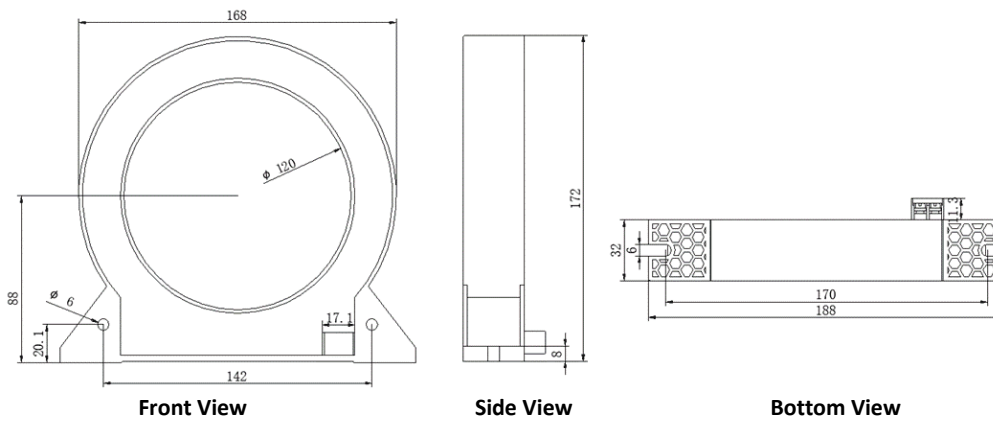

Figure 2-22 PMC-MIR-120 Dimensions

2.7.6.5 PMC-MIR-265*103

Unit: mm

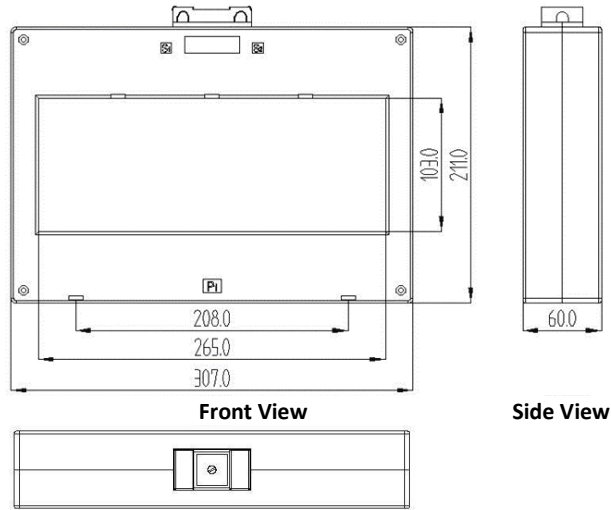

Figure 2-23 PMC-MIR-265*103 Dimensions

2.7.7 NTC Transducer Dimensions

2.7.7.1 NTC-Y4

Unit: mm

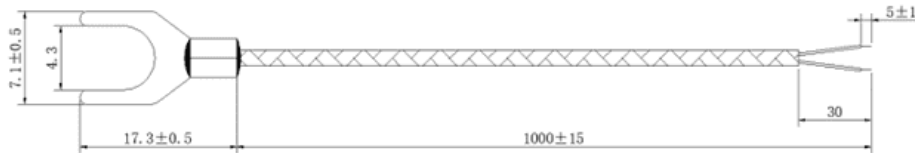

Figure 2-24 NTC-Y4 Dimensions

2.7.7.2 NTC-Y6

Unit: mm

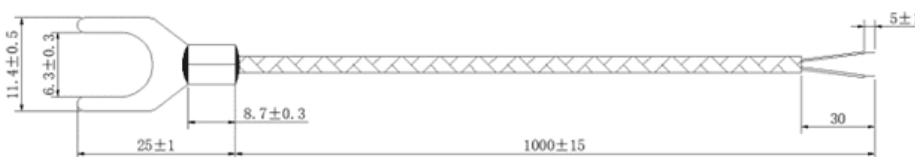

Figure 2-25 NTC-Y6 Dimensions

2.7.7.3 NTC-Y12

Unit: mm

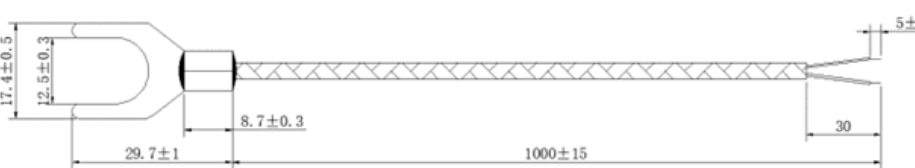

Figure 2-26 NTC-Y12 Dimensions

2.7.7.4 NTC-1041

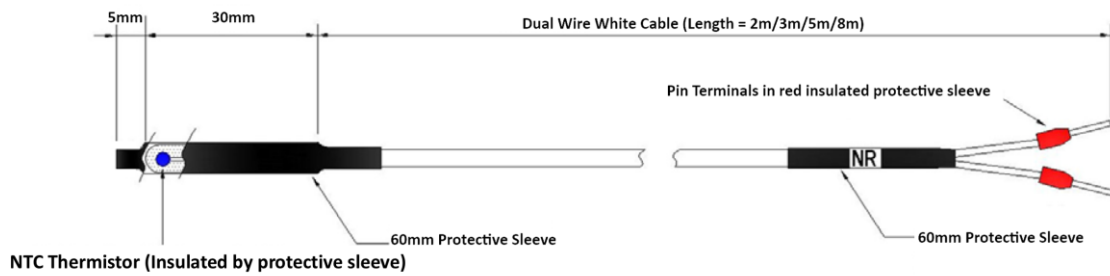

Figure 2-27 NTC-1041 Dimensions

2.8 Mounting

2.8.1 DIN-Rail Mounting for Relay and Expansion Modules

The relay and the expansion modules should be installed in a dry environment with no dust and kept away from heat, radiation and electrical noise sources.

Installation steps:

- Pre-drill the mounting holes for the DIN Rail and ensure it is already in place before installation.
- Move the installation clips at the back of the relay/module downward to the “unlock” position.
- Align the top of the mounting channel at the back of the relay/module at an angle against the top of the DIN Rail, as shown in the figure below.
- Rotate the bottom of the relay/module towards the back while applying a slight pressure to ensure the device is completely and securely fixed to the DIN Rail.
- Push the installation clips upward to the “lock” position to secure the relay/module to the DIN Rail.

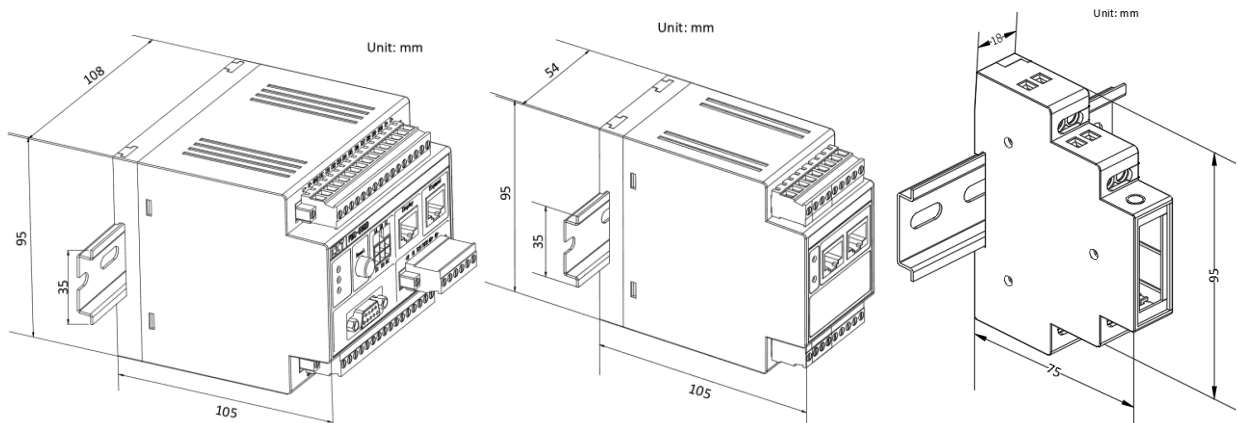

Figure 2-28 DIN Rail Mounting for Relay/Expansion Module

2.8.2 Panel Cutout Mounting for HMI Module

The HMI module should be installed in a dry environment with no dust and kept away from heat, radiation and electrical noise sources.

Installation steps:

- Remove the mounting slide bars from the HMI module.
- Fit the meter through a 44mm x 65mm cutout, as shown in Figure 2-29.
- Re-install the mounting slide bars and tighten the screws against the panel to secure the HMI module.

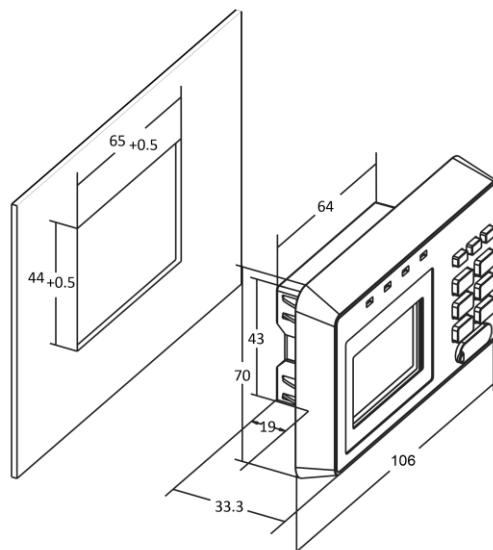

Figure 2-29 Panel Cutout Mounting for HMI Module

2.9 Connections with other modules



Figure 2-30 Connections with other modules

2.9.1 HMI Module Connection

Connect the RJ45 port on the rear of the PMC-550D HMI module to the relay using the attached Cat5e UTP Cable with magnetic ring. The HMI module receives power from the relay's **Display** port.

2.9.2 Optional PMC-KT Module Connection

2.9.2.1 Power and Communication Connection

Connect the RJ45 port of the PMC-KT expansion module to the PMC-550D relay using the attached Cat6 Flat Cable. The PMC-KT module receives power from the relay.

To connect both PMC-KT and PMC-KR expansion modules to the PMC-550D relay, use the RJ45 Ethernet cable to connect the first module to the relay. And use the RJ45 Ethernet cable to connect the first module to the second module. The module order does not matter.

2.9.2.2 NTC Input Connection

The 2-wire outputs of the negative temperature coefficient (NTC) sensor shall be connected to the TC Input of the relay. Connect the red wire to the positive terminals (TC11 / TC21 / TC31 / TC41 / TC51 / TC61) and connect the white lead to the negative terminals (TC12 / TC22 / TC32 / TC42 / TC52 / TC62).

2.9.2.3 DO6 (Form C) Output Connection

The expansion module comes with one Form C (DO6) output. When the relay coil is de-energized, the contact between DO61 and DO62 is open, while the contact between DO62 and DO63 is closed.

2.9.2.4 Digital Input Connection

The two digital inputs on the expansion module PMC-KT only support being internally wetted @ 24VDC. Connect a dry contact, switch or jumper to the input.

2.9.3 Optional PMC-KR Module Connection

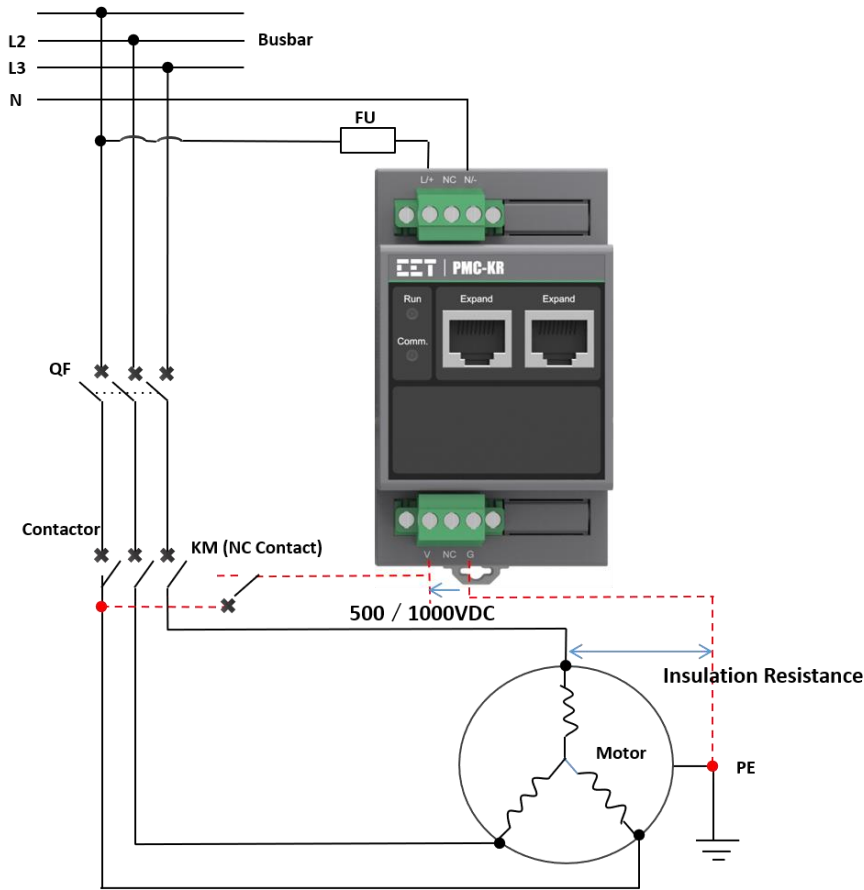

Figure 2-31 PMC-KT Connection

2.9.3.1 Power Connection

The L/+, N/- terminals on the PMC-KR module shall connect to a 95-250VAC/DC power source.

For an AC supply, connect the live wire to the L/+ terminal and the neutral wire to the N/- terminal.

For a DC supply, connect the positive wire to the L/+ terminal and the negative wire to the N/- terminal.

2.9.3.2 Communication Connection

Connect the PMC-KT expansion module to the PMC-550D relay via its **Expand** port using the attached Cat6 Flat Cable. To connect both PMC-KT and PMC-KR expansion modules to the PMC-550D relay, use the RJ45 cable to connect the first module to the relay. And use the RJ45 Ethernet cable to connect the first module to the second module. The module order does not matter.

2.9.3.3 DC Voltage Output Connection

Connect the V terminal with the live supply conductor and the G terminal to the earth for insulation resistance measuring.

2.10 PMC-MTA Wiring

For PMC-MTA-1A/5A/25A/100A/300A, these MTAs come with a pluggable connector at the end of the output, which consists of 5 wires with colorful insulated cover, **IA** (yellow), **IB** (green), **IC** (red), **IN** (black) and **SH** (black). Insert the pluggable connector securely into the current input terminals on the PMC-550D. Put the motor wires through the aperture in the MTA. Take care of the correct phase sequence and feed through the direction indicated on the MTA.

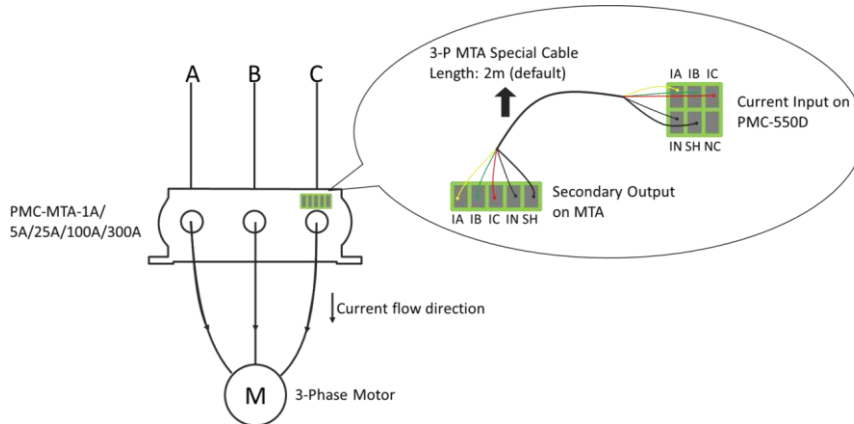

Figure 2-32 PMC-MTA-1A/5A/25A/100A/300A Connections

For PMC-MTA-400A-T and PMC-MTA-800A-T, one relay should be connected to 3 pieces of identical MTA which transform the motor current IA, IB and IC separately. Connect the MTA's output wires to the relay via the attached pluggable connector. The red wire from the I terminal of the 3 MTAs should be independently connected to the **IA**, **IB**, and **IC** of the relay's current input. The black wires from the 3 MTA's **IN** should be connected to the relay's **IN**, and the black **SH** wires should be connected to the relay's **SH**. Please put the 3-phase motor wires through 3 individual MTAs separately. Please ensure the phase sequence is correct and feed the wires through the direction indicated on the MTA.

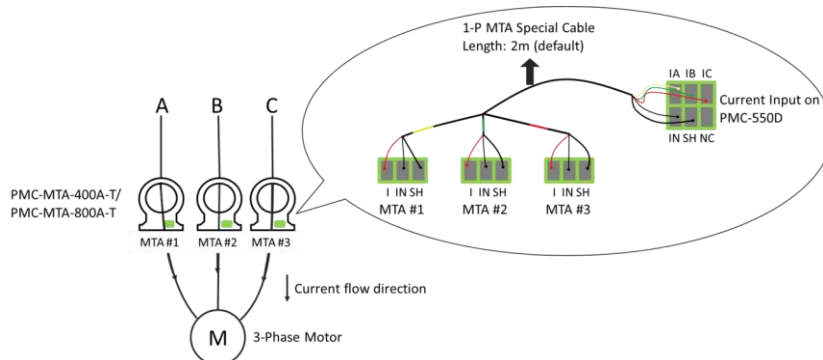

Figure 2-33 PMC-MTA-400A-T / PMC-MTA-800A-T Connections

Notes

1. The MTAs should be installed upstream of the circuit under VFD, star-delta and 2-speed control applications.
2. The rated input of Current Input terminals is 1.25V voltage. Please **DO NOT** input a current or a higher voltage to the relay.
3. **DO NOT** ground the IN terminal on the relay.

2.11 Digital Output Wiring

The relay comes standard with a form B (DO1) and four form A (DO2 to DO5) output contacts. The DO2 supports NC or NO contacts based on the selected model option. DO1 to DO4 are rated for continuous carry current of 8A. DO5 is rated for continuous carry current of 5A (Refer to Appendix C – Technical Specification).

2.12 Digital Input Wiring

The ten digital inputs on the relay support can be internally or externally wetted based on the selected model option. For DI internally wetted @ 24VDC, a PMC-KI module will be required to convert the sampling voltage if the user desires to use 110VDC/AC or 220VDC/AC voltage. In this condition, the **DI Excitation** shall be configured as **External**, and the minimum debounce (also called hysteresis sometimes) time shall be 600ms. The following figure illustrates the connection between the PMC-KI and inputs on the relay.

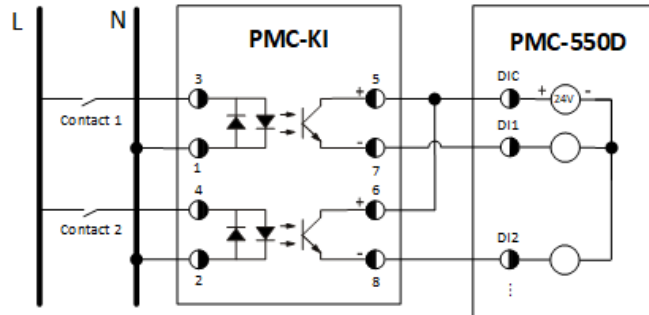

Figure 2-34 Digital Input Connection with PMC-KI Converter

2.13 Residual Current Input Wiring

The following figure illustrates the Residual Current Input connections on the PMC-550D. Put the motor circuit's three-phase and neutral (when used) wires through the center of the PMC-MIR residual current transducer. Connect the PMC-MIR's output to the relay's -IR and IR terminals.

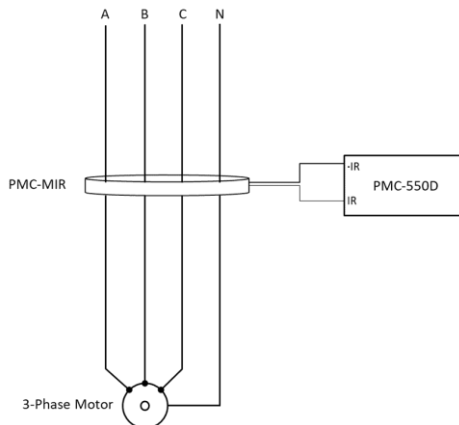

Figure 2-35 Residual Current Input Connection

2.14 Power Supply Wiring

The relay's L/+, N/- terminals shall connect to a 95-250VAC/DC power source.

For an AC supply, connect the live wire to the L/+ terminal and the neutral wire to the N/- terminal.

For a DC supply, connect the positive wire to the L/+ terminal and the negative wire to the N/- terminal.

2.15 Analog Output Wiring

The relay offers an Analog Output for operating a remote panel meter or as an input to the distributed control system (DCS). Please note that the relay supplies 24VDC voltage for the analog output.

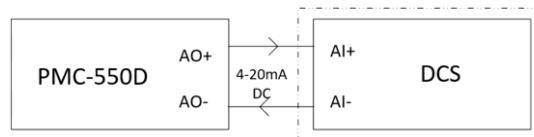

Figure 2-36 Analog Output Wiring

2.16 Communications Wiring

2.16.1 RS-485 Wiring

The following figure illustrates the RS-485 communication wiring on the PMC-550D.

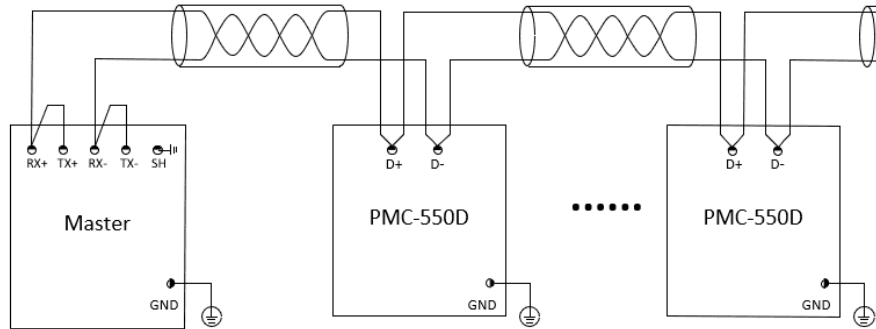

Figure 2-37 Wiring Diagram of RS-485 Communication

The PMC-550D provides two standard RS-485 ports. Up to 32 devices can be connected on an RS-485 bus. The overall length of the RS-485 cable connecting all devices should not exceed 1200m.

If the master station does not have an RS-485 communication port, an Ethernet-to-RS-485 gateway or USB/RS-485 converter with optically isolated output and surge protection should be used.

2.16.2 Optional PROFIBUS Wiring

The PMC-550D is integrated into a PROFIBUS DP network by using either a DB9 connector or a 3 Position Terminal Block. The following figure illustrates the DB9 interface pinout. Please install a Profibus card with driver on the PC to connect the PMC-550D via the PROFIBUS interface directly.

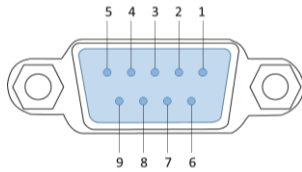

Figure 2-38 DB9 Connector Pinout



Figure 2-39 3 Position Terminal Block

The following table illustrates the functions assigned to the pinout of the D-SUB9 connector and 3-pos. terminal block.

3 Position Terminal	DB9 (pin)	Signal	Function
B	3	D (B) positive	Data receive and transmit (positive)
A	8	D (A) negative	Data receive and transmit (negative)
DGND	5	DGND	Reference potential for +5V and data
--	6	VP	+5V for terminating resistors (active termination)

Table 2-6 Pin Assignments for the DB9 Connector on PMC-550D

For the applications where there are two different systems required PROFIBUS DP connections, for example, a DCS (Distributed Control System) and an ECMS (Electric Control and Monitoring System), the PMC-550D optionally provide an additional PROFIBUS DP connection via the D+/B, D-/A terminals of the P1 (RS-485) port.

2.16.3 Ethernet Wiring

2.16.3.1 Ethernet Port (10Base-T/100Base-TX)

RJ45 Connector	Pin	Meaning
	1	Transmit Data+
	2	Transmit Data-
	3	Receive Data+
	4,5,7,8,	NC
	6	Receive Data-

Table 2-7 RJ45 Connector Pin Description for 10Base-T/100Base-TX Applications

The PMC-550D supports two kinds of Ethernet connections, which are **Normal Model** and **Switch Mode**. The topologies are depicted as below.

2.16.3.2 Normal Mode

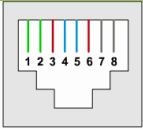
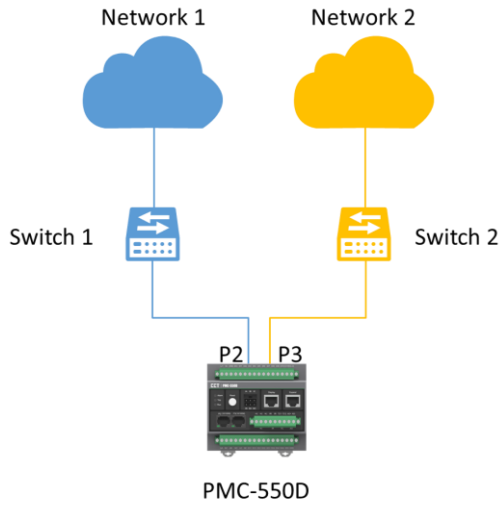

Figure 2-40 Normal Mode Connection

2.16.3.3 Switch Mode

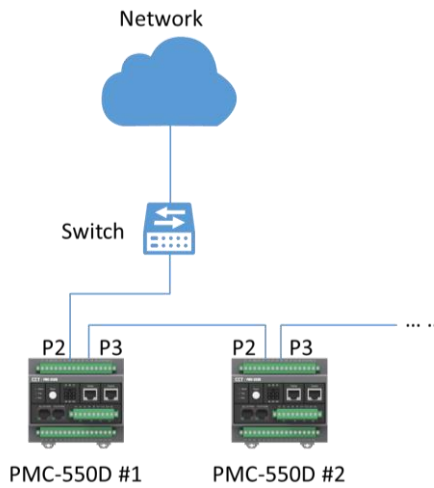

Figure 2-41 Switch Mode Connection

2.17 PTC/NTC Thermistor Connection

Connect the positive temperature coefficient (PTC) or negative temperature coefficient (NTC) thermistor from the motor to the relay's TC11 (positive) and TC12 (negative) terminals with shielded twisted pair (STP) cable. Please refer to the following table for the maximum cable lengths.

Wire Size	Maximum Length
0.5 mm ² (20AWG)	180m
1.5 mm ² (15AWG)	550m
2.5 mm ² (13AWG)	900m

Table 2-8 Maximum Cable Length for PTC Connection

2.18 Ground Connection

Connect the GND terminal of the relay to the chassis or cabinet ground.

2.19 Starter Wiring

The relay supports multiple motor starter modes. Please read this section carefully before installation and choose the correct starter mode. The following starter modes are supported:

- Direct-On-Line (DOL)
- Reduce-voltage
- Forward / Reverse
- Two-Speed

2.19.1 Direct-On-Line Start

Use this mode to start/stop a motor in a one-direction rotation. The following diagram shows the wiring for DOL Operation. The main contactor KM is connected to DO1 and DO3 for the control function. A pair of auxiliary contacts of KM is connected to DI7 for contactor status supervision. The motor can be started locally via DI2 and stopped via DI3. The PMC-KR and PMC-KT modules are used for insulation resistance measuring and overtemperature protection.

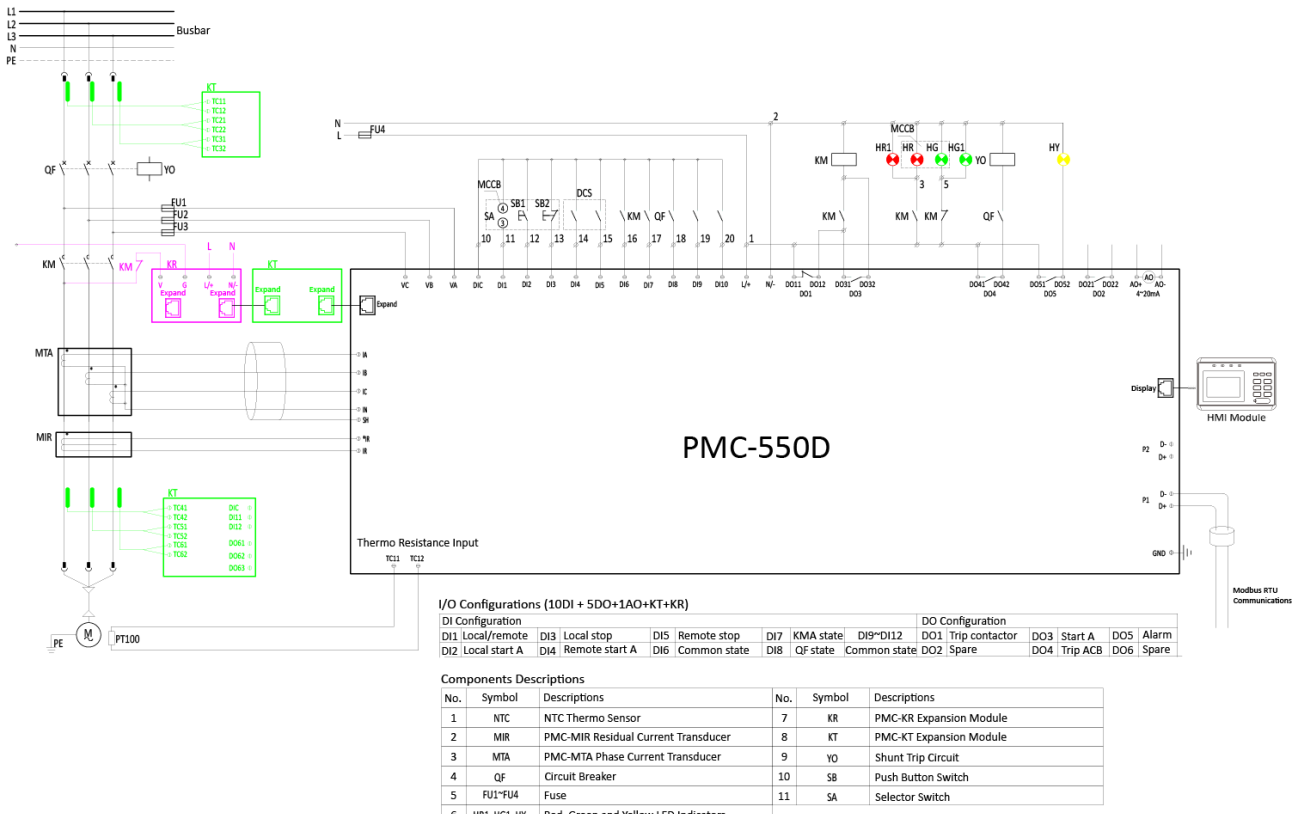

Figure 2-42 DOL Start Schematic Diagram

2.19.2 Reduce-voltage Start

Induction motor draws excessive current when starting at full voltage. This might cause voltage drop at point-of-common-coupling. Thus, the reduce-voltage start is applied to reduce the starting current. The relay supports the reduce-voltage start methods, including star-delta start, auto-transformer start, and resistance Start.

Star-Delta Start

In star-delta starting method, a motor is connected in a wye connection throughout the starting period. Once the motor's running speed reaches its normal speed within the specified time delay, it begins running in a delta connection.

The following diagram shows the wiring for the star-delta start. DO1 is connected to the main contactor (KM1) for protection tripping. DO2 is used to control the star contactor (KM3), and DO3 is used to control the delta contactor (KM2). Two pairs of auxiliary contacts of KM1 and KM2 contactors are connected to DI6 and DI7 for contactor status supervision. The motor can be locally started via DI2 and stopped via DI3.

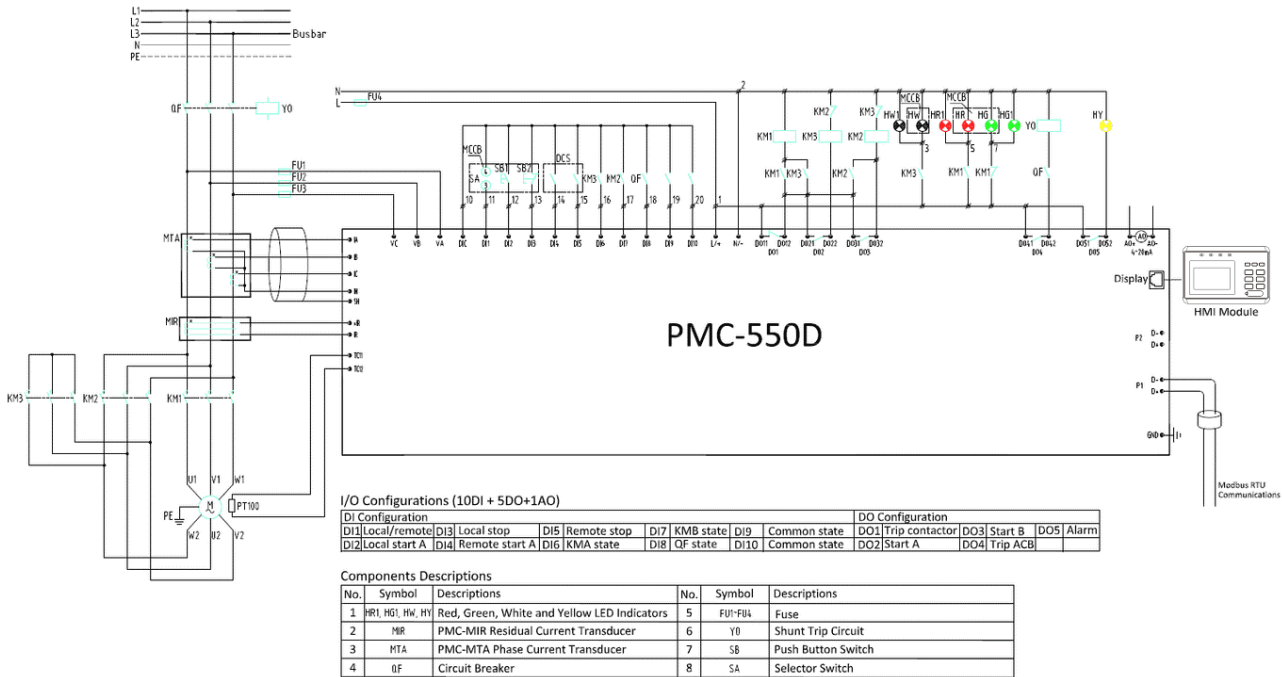

Figure 2-43 Star-Delta Start Operation Schematic Diagram

Auto-transformer Start

In auto-transformer starting mode, the motor is connected to a tapping of an auto-transformer to obtain a suitable voltage throughout the start period. Once the motor's running speed reaches its normal speed within the specified time delay, the auto-transformer will be isolated from the motor circuit, and the motor begins to run at the full rated voltage.

The following diagram shows the auto-transformer starter control. DO1 is used for protection trip output. DO2 controls the start circuit (KM2 – transformer secondary contactor, KM3 – transformer primary contactor). DO3 is used to control the running circuit (KM1). Two pairs of auxiliary contacts of KM2 and KM1 are connected to DI6 to DI7 for contactor status supervision. The motor can be locally started via DI2 and stopped via DI3.

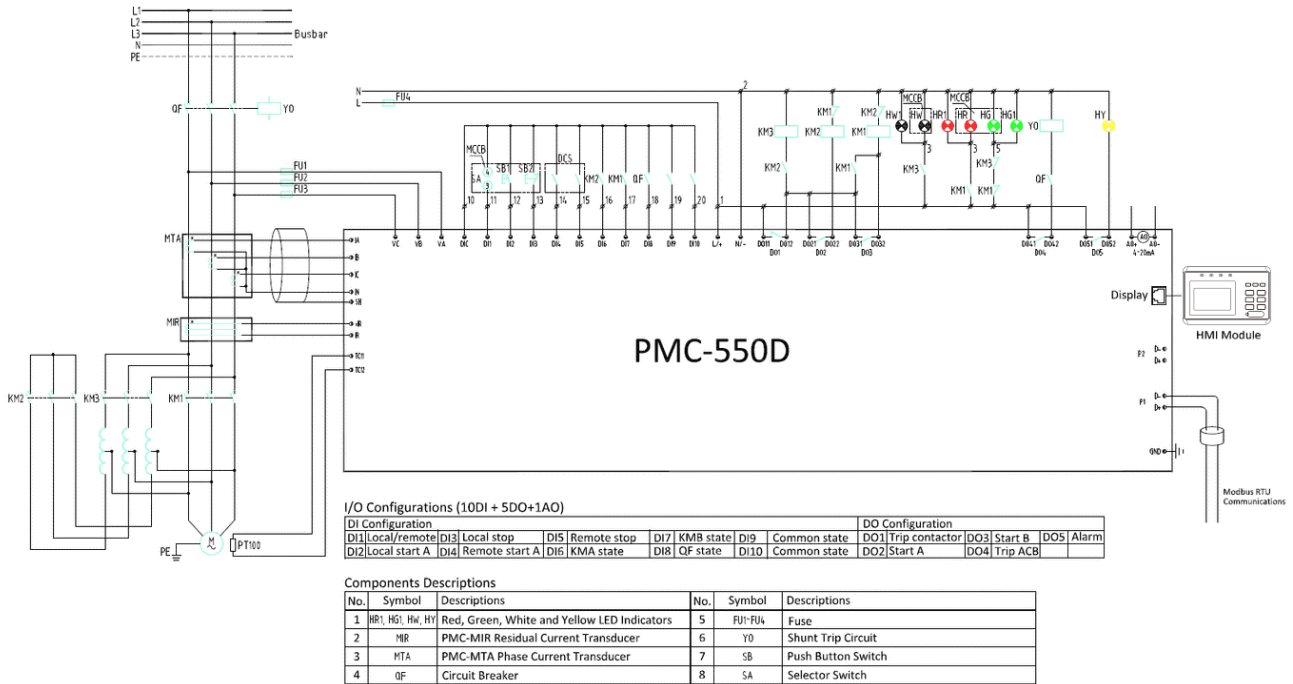

Figure 2-44 Auto-Transformer Start Operation Schematic Diagram

Rotor Resistance Start

In Rotor resistance starting method, the motor is connected to a variable resistor in series to obtain a reduced voltage throughout the start period. Once the motor current reaches the predefined threshold after a specified time delay, the resistor will be disconnected from the motor circuit, and the motor begins to run at a full rated voltage.

The following diagram shows the resistance start operation. DO1 is used for protection trip output. DO2 controls the start circuit (KM2), and DO3 controls the running circuit (KM1). Two pairs of auxiliary contacts of KM2 and KM1 are connected to DI6 and DI7 for contactor status supervision. The motor can be started locally via DI2 and stopped via DI3.

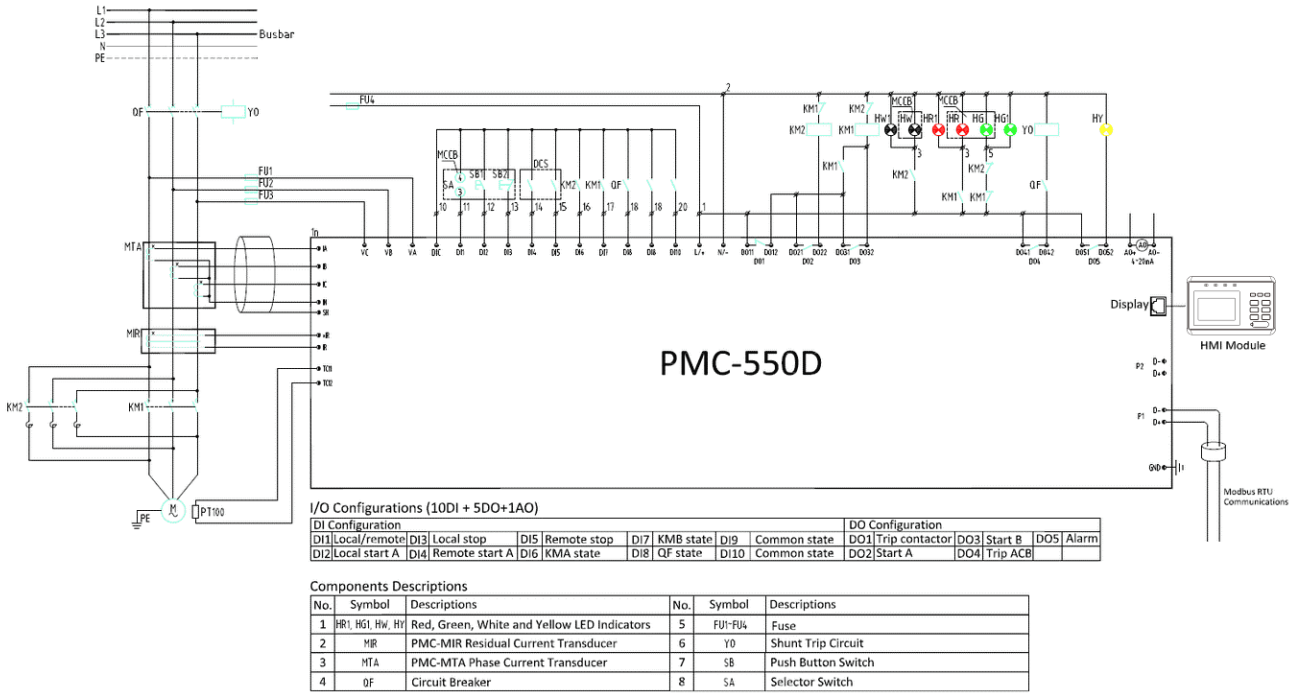

Figure 2-45 Rotor Resistance Start Operation Schematic Diagram

2.19.3 Forward / Reverse Start

Use this function to start/stop a motor in a two-direction rotation, forward and backward or upward and downward.

The following diagram illustrates the wiring for Forward-reverse operation. The DO1 is used for protection trip output. DO2 controls the forward contactor (KM1), and DO3 controls the reverse contactor (KM2). Two pairs of auxiliary contacts of KM1 and KM2 are connected to DI7 and DI8 for contactor status supervision. The motor can be started locally via DI2 (Forward) or DI3 (Reverse) and stopped via DI3.

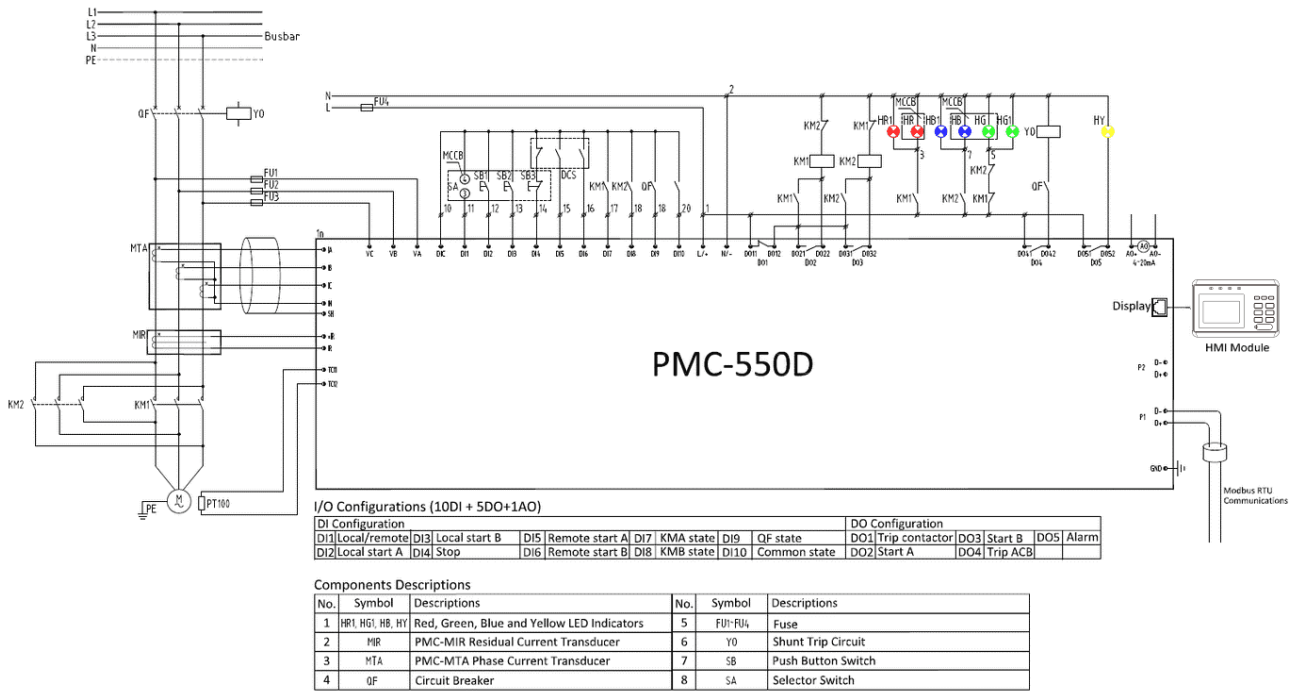

Figure 2-46 Forward / Reverse Start Operation Schematic Diagram

Notes:

- Opposite-direction running is only possible after the motor is stopped and the preset delay time has elapsed.
- If a motor is already in a one-direction rotation, the start command in the same direction will be ignored.
- Restart in the same direction without consideration of the preset delay time.

2.19.4 Two-Speed Start

Use this function to start/stop a motor running at two speeds in one direction of rotation.

The following diagram illustrates the wiring for two-speed operation. The DO1 is used for protection trip output. DO2 controls speed 1 contactor (KM1), and DO3 controls speed 2 contactor (KM2 & KM3). Two pairs of auxiliary contacts of KM1 and KM2 are connected to DI7 and DI8 for contactor status supervision. The motor can be locally started via DI2 (Speed 1) / DI3 (Speed 2) and stopped via DI4.

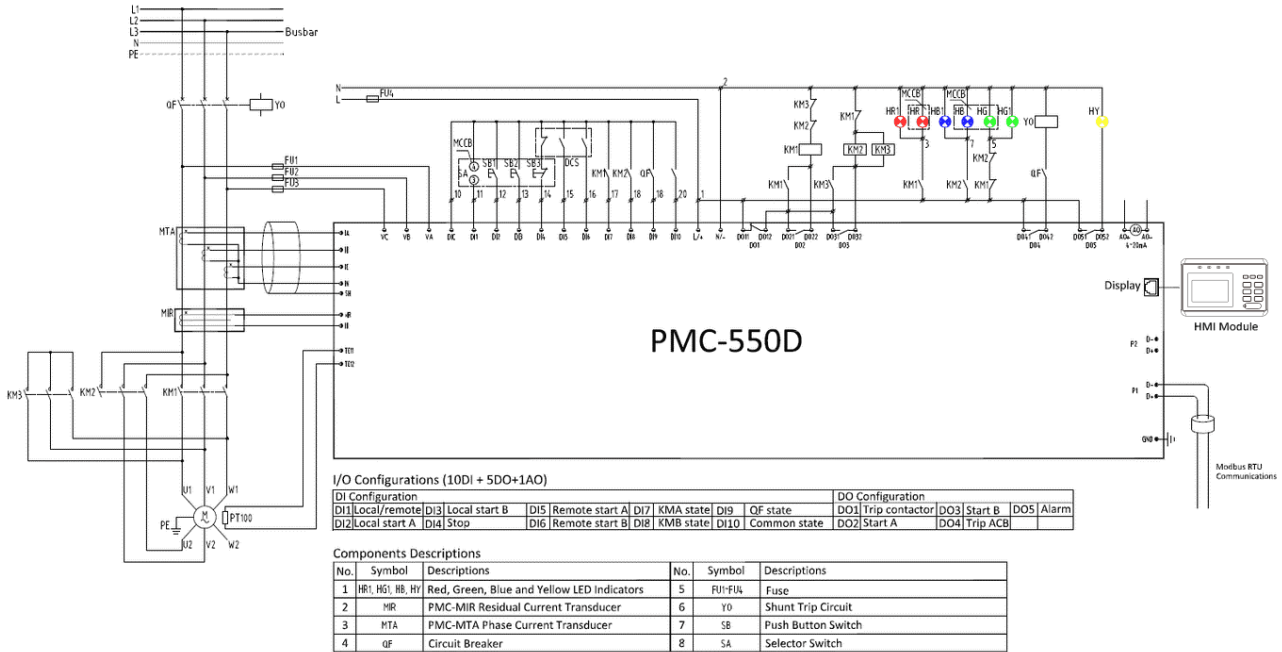

Figure 2-47 Two-Speed Start Operation Schematic Diagram

Notes:

- Alternative speed is only possible after the motor is stopped and the preset delay time has elapsed.
- If a motor is already running at a certain speed, the start command at the same speed will be ignored.
- Restart at the same speed without consideration of the preset delay time.

Chapter 3 HMI Display Module

The PMC-550D Human Machine Interface (HMI) display module has a large, easy-to-read LCD with a backlight and six navigation buttons for data display and meter configuration. It has four LED indicators for the relay status, protection trip/alarm status, and motor running status, and three buttons for motor start/stop control.



Figure 3-1 PMC-550D HMI Interface

3.1 LED Indicators

The meanings for the four indicators are described below:

LED Indicators	Color	Status Description
Run	Green	Blink once per second – the device is running normally
Trip	Red	On – trip events occur
Alarm	Yellow	On – alarm events occur, or self-check failed
State	Green	Blink once per 0.2s – motor is starting; On – motor is running; Off – motor stops

Table 3-1 HMI LED Indicators

The Trip/Alarm indicator will illuminate and latch in after the target condition occurs. The latched LED must be reset using the Reset button or the Reset command via DI or Communications if the trip/alarm conditions have cleared.

3.2 Navigation Buttons

The following table describes the functions of the navigation buttons <◀>, <▶>, <▲>, <▼>, <←> and <→>. Holding the <←> button for 1s, the Trip/Alarm LED will turn off if the trip/alarm events conditions have cleared. While the trip/alarm condition remains, the Trip/Alarm LED stay lit.

Menu/Screen	Buttons		
	◀, ▶, ▲, and ▼	←	→
Home	Toggles between the Home pages.	Enter the Main Menu	Ignored
Metering, DI/DO, View Para., Logs, Statistics, Info., Setup, Maint.	<ul style="list-style-type: none"> Before a menu/sub-menu is selected, pressing ▲ or ▼ shifts the cursor down/up in the Main menu/Sub-menu. Inside a particular sub-menu, pressing ◀ or ▶ moves forward/backward to display different parameters. 	Enter the selected menu/sub-menu.	Returns to the previous level menu or screen
Setup, Maint.	<p>If a parameter is selected in the sub-menu of Setup/Maint.,</p> <ul style="list-style-type: none"> For a numeric parameter, pressing ▲ or ▼ increments or decrements a numeric value by one digit and pressing ◀ or ▶ shifts the cursor to the left or right by one position. For an enumerated parameter, press ▲ to scroll through the selection list. 	<ul style="list-style-type: none"> Enter the selected parameter modification screen. Save the modification. Start the comm. test or control logic test. 	<ul style="list-style-type: none"> Exit the parameter setup screen without saving the modifications. Exit the comm. test of control logic test.

Table 3-2 Overview of HMI Navigation Buttons

3.3 Control Buttons

The following table describes the Start A, Start B and Stop button functions under different starter modes.

Control Functions	Buttons		
	Start A	Start B	Stop
Direct-On-Line	Start	-- (Not used)	Stop
Reduce-voltage	Reduce-voltage start	Full-voltage running	
Forward / Reverse	Forward	Reverse	
Two-Speed	Speed 1	Speed 2	

Table 3-3 Overview of Front Panel Control Buttons

The user can use the control buttons on the HMI module to start/stop the motor based on the **Control Key** setting (Under **Setup** -> **1 System** menu on the HMI module). The control buttons are not operational if the **Control Key** is set to **Disable**. **Control Key** set to **Emergency** means the HMI button control is always valid regardless of the **DI Local/Remote** setting. And under other circumstances, the **Control Key** setting has to be consistent with the **DI Local/Remote** to make the control buttons functional. If none of the DI is configured as **Local/Remote**, the **Control Key** has to be set to **Local** so that the HMI button control can make sense.

3.4 HMI Display

The HMI display consists of four lines with twenty-one characters per line. The following sections provide an overview of its displays.

3.4.1 Home Screen

The HMI display has a Home screen consisting of three screens, and pressing the ◀, ▶, ▲ or ▼ buttons to scroll between the screens.

The first screen shows the metering of line-to-line voltage U (UAB), phase current I (IA), percent of I (IA) / Ie, motor control mode (Local or Remote), RS-485 communication state (COM blinking means communications active), and the DI state (1 means close, 0 means open, 0000000000 stands for DI1 to DI10 open). If the programmable logic is exported to the relay, the symbol Ⓛ will display as shown on the following screen.

On the second screen, the first line shows the connection status between the HMI module and the relay. The second line indicates whether the hardware of the HMI module is compatible with the relay. The third and fourth lines show the connection status of the PMC-KT and PMC-KR modules to the relay.

The third screen shows the motor start blocked/unblocked state and the DO state (1 means close, 0 means open, 01000 stands for DO2 close with other DOs open). The block reason (such as self-check failed, protection trip) and remaining block time will display if the motor start is blocked.

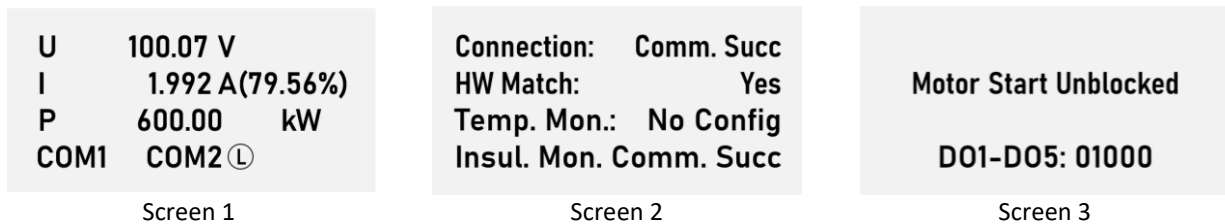

Figure 3-2 HMI Display Home Screen

The LCD will return to the Home screen if there is no HMI activity for 3 minutes or longer.

3.4.2 Main Menu

Pressing the <←> button will enter the Main Menu screen. The main menu consists of 8 items, **Metering, DI/DO, View Para., Logs, Setup, Statistics, Maint.,** and **Info.** Each item includes a sub-menus for detailed data viewing or setup configurations. All data and setup parameters can be viewed without a password, but a valid HMI Password is required for making setup changes. The default HMI Password is "0000".

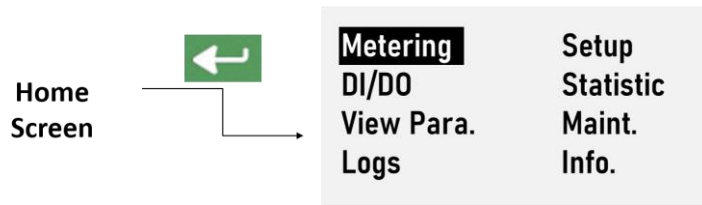

Figure 3-3 HMI Main Menu screen

The following section illustrates the available measurements or parameters for each menu.

3.4.3 Metering

The **Metering** menu consists of **Relay Data, Metering Data** and **Harmonic**. The following sections provide a quick overview of these screens.

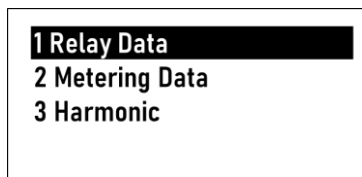

Figure 3-4 Metering menu

3.4.3.1 Relay Data

Enter the **Relay Data** sub-menu, and the following screens are available.

<table border="1"> <tr><td>IA</td><td>7.000 A</td><td>30.0°</td></tr> <tr><td>IB</td><td>7.500 A</td><td>270.0°</td></tr> <tr><td>IC</td><td>8.000 A</td><td>150.0°</td></tr> <tr><td>IR</td><td>1000.0mA</td><td></td></tr> </table>	IA	7.000 A	30.0°	IB	7.500 A	270.0°	IC	8.000 A	150.0°	IR	1000.0mA		<table border="1"> <tr><td>IA</td><td>700.00 %le</td></tr> <tr><td>IB</td><td>750.00 %le</td></tr> <tr><td>IC</td><td>800.00 %le</td></tr> </table>	IA	700.00 %le	IB	750.00 %le	IC	800.00 %le	<table border="1"> <tr><td>P</td><td>600.00 kW</td></tr> <tr><td>Q</td><td>500.00 kvar</td></tr> <tr><td>PF</td><td>0.768</td></tr> </table>	P	600.00 kW	Q	500.00 kvar	PF	0.768		
IA	7.000 A	30.0°																										
IB	7.500 A	270.0°																										
IC	8.000 A	150.0°																										
IR	1000.0mA																											
IA	700.00 %le																											
IB	750.00 %le																											
IC	800.00 %le																											
P	600.00 kW																											
Q	500.00 kvar																											
PF	0.768																											
<table border="1"> <tr><td>UAB</td><td>140.00 V</td><td>0°</td></tr> <tr><td>UBC</td><td>150.00 V</td><td>240.0°</td></tr> <tr><td>UCA</td><td>160.00 V</td><td>120.0°</td></tr> <tr><td>f</td><td>50.00 Hz</td><td></td></tr> </table>	UAB	140.00 V	0°	UBC	150.00 V	240.0°	UCA	160.00 V	120.0°	f	50.00 Hz		<table border="1"> <tr><td>I1</td><td>5.500A</td></tr> <tr><td>I2</td><td>6.000A</td></tr> <tr><td>3I0</td><td>5.000A</td></tr> <tr><td>I Unbalance</td><td>0.32%</td></tr> </table>	I1	5.500A	I2	6.000A	3I0	5.000A	I Unbalance	0.32%	<table border="1"> <tr><td>Cooling Time</td><td>60.0s</td></tr> <tr><td>Heat Capacity</td><td>50.0%</td></tr> <tr><td>Thermo R</td><td>30.000kΩ</td></tr> </table>	Cooling Time	60.0s	Heat Capacity	50.0%	Thermo R	30.000kΩ
UAB	140.00 V	0°																										
UBC	150.00 V	240.0°																										
UCA	160.00 V	120.0°																										
f	50.00 Hz																											
I1	5.500A																											
I2	6.000A																											
3I0	5.000A																											
I Unbalance	0.32%																											
Cooling Time	60.0s																											
Heat Capacity	50.0%																											
Thermo R	30.000kΩ																											

Figure 3-5 Relay Data

3.4.3.2 Metering Data

Enter the **Metering Data** sub-menu, and the following screens are available.

<table border="1"> <tr><td>Ia</td><td>5.000 A</td><td>30.0°</td></tr> <tr><td>Ib</td><td>5.500 A</td><td>270.0°</td></tr> <tr><td>Ic</td><td>6.000 A</td><td>150.0°</td></tr> </table>	Ia	5.000 A	30.0°	Ib	5.500 A	270.0°	Ic	6.000 A	150.0°	<table border="1"> <tr><td>Ia</td><td>500.00 %le</td></tr> <tr><td>Ib</td><td>550.00 %le</td></tr> <tr><td>Ic</td><td>600.00 %le</td></tr> </table>	Ia	500.00 %le	Ib	550.00 %le	Ic	600.00 %le	<table border="1"> <tr><td>Uab</td><td>100.00 V</td><td>0°</td></tr> <tr><td>Ubc</td><td>110.00 V</td><td>240.0°</td></tr> <tr><td>Uca</td><td>120.00 V</td><td>120.0°</td></tr> </table>	Uab	100.00 V	0°	Ubc	110.00 V	240.0°	Uca	120.00 V	120.0°
Ia	5.000 A	30.0°																								
Ib	5.500 A	270.0°																								
Ic	6.000 A	150.0°																								
Ia	500.00 %le																									
Ib	550.00 %le																									
Ic	600.00 %le																									
Uab	100.00 V	0°																								
Ubc	110.00 V	240.0°																								
Uca	120.00 V	120.0°																								
<table border="1"> <tr><td>P</td><td>750.00 kW</td></tr> <tr><td>Q</td><td>650.00 kvar</td></tr> <tr><td>PF</td><td>0.756</td></tr> </table>	P	750.00 kW	Q	650.00 kvar	PF	0.756	<table border="1"> <tr><td>kWh Import</td><td>123456.78kWh</td></tr> <tr><td>kvarh Import</td><td>2.00 kvarh</td></tr> </table>	kWh Import	123456.78kWh	kvarh Import	2.00 kvarh	<table border="1"> <tr><td>kWh Export</td><td>76543.21 kWh</td></tr> <tr><td>kvarh Export</td><td>8.88 kvarh</td></tr> </table>	kWh Export	76543.21 kWh	kvarh Export	8.88 kvarh										
P	750.00 kW																									
Q	650.00 kvar																									
PF	0.756																									
kWh Import	123456.78kWh																									
kvarh Import	2.00 kvarh																									
kWh Export	76543.21 kWh																									
kvarh Export	8.88 kvarh																									

Figure 3-6 Metering Data

3.4.3.3 Harmonic

Enter the **Harmonic** sub-menu, and the following screens are available.

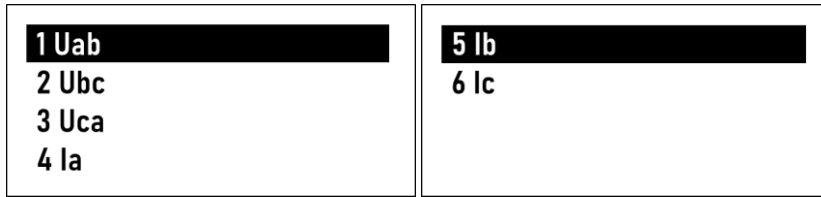

Figure 3-7 Harmonic Parameters

Press <←> to view the THD, TOHD, TEHD and the Individual Harmonic measurements from the 2nd to 31st for the selected Harmonic parameter.



Figure 3-8 Harmonic Measurements

3.4.4 DI/DO

The **DI/DO** menu consists of DI Status and DO Status. The following section provides a quick overview of these screens.

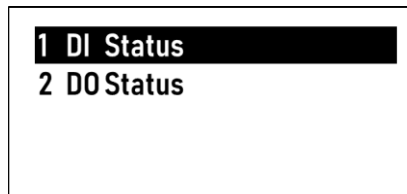

Figure 3-9 DI/DO menu

3.4.4.1 DI Status

The **DI Status** sub-menu shows the DI status. If the PMC-KT module is equipped, the DI11 and DI12 stand for the 2xDI on the PMC-KT module. “o” means DI open, while “●” means DI closed.



Figure 3-10 DI Status

3.4.4.2 DO Status

The **DO Status** sub-menu shows the DO status. If the PMC-KT module is equipped, the DO6 stands for the DO on the module. “o” means DO released while “●” means DO operated.



Figure 3-11 DO Status

3.4.5 View Parameters

The **View Parameters** menu provides access to check the current settings on the relay without requiring an HMI password. For the detailed screens, please refer to **Section 3.4.7 Setup**.

3.4.6 Logs

The **Logs** menu consists of **DI/DO Logs**, **Protection Logs**, **Diagnostic Logs**, **Maintenance Logs**, **Start Report**, **Stop Report** and **Insulation Logs** (if insulation monitoring is enabled). The following section provides a quick overview of these screens.

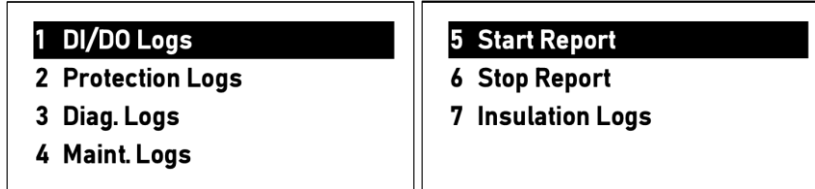

Figure 3-12 Logs menu

3.4.6.1 DI/DO Logs

The **DI/DO Logs** sub-menu displays the DIx opened/closed or DOx act/return events (1 event per page) with DI/DO function and timestamp on the HMI display.

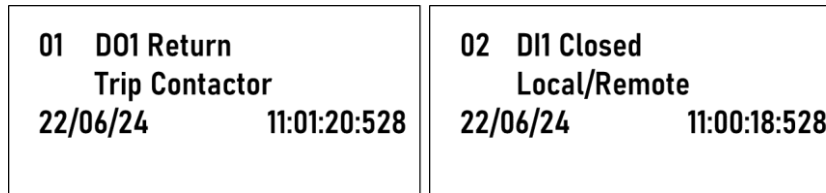

Figure 3-13 DI/DO Logs

3.4.6.2 Protection Logs

The relay supports the display of the **Protection Logs** with up to 64 events (one event per page) such as Thermal OL (Overload) Trip, Undervolt. (Undervoltage) Restart Fail, with characteristics parameters and timestamp. Please refer to **Appendix A – SOE and Protection Log Classifications** for the details.

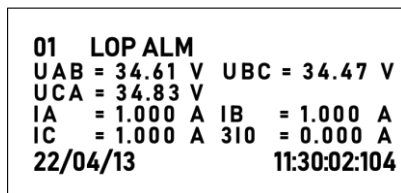

Figure 3-14 Protection Logs

3.4.6.3 Maint. Logs

The **Maint. Logs** sub-menu displays the device power on/off, clear data operations (e.g., Energy, SOE, Statistics), manual WFR trigger and other manual operations with a timestamp.

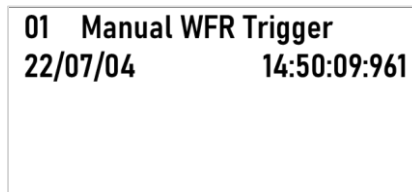

Figure 3-15 Maintenance Logs

3.4.6.4 Diag. Logs

The **Diag. Logs** sub-menu displays the Metering Error, Device Parameters Error or other fault events defined in **Appendix A – SOE and Protection Log Classifications** with a timestamp.

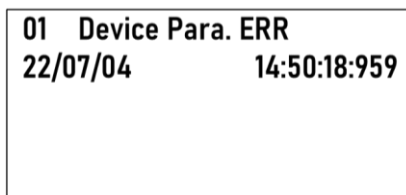

Figure 3-16 Diag. Logs

3.4.6.5 Start Report

The relay supports the display of **Start Report** with up to 64 start logs recording the **Start Control Source, Maximum Start Current, Minimum Start Voltage, Motor Start Time, Start Result** and **Timestamp** for each motor start.

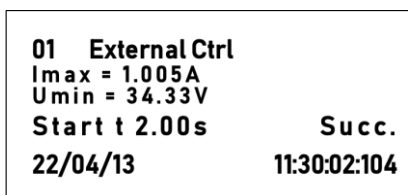

Figure 3-17 Start Report

3.4.6.6 Stop Report

The relay also supports the display of **Stop Report** with up to 64 stop logs recording the **Stop Control Source, 3-phase Currents Magnitude** and **Timestamp** for each motor stop.

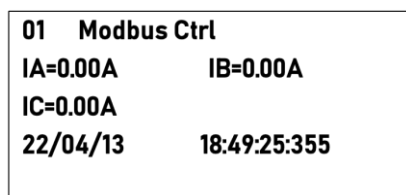

Figure 3-18 Stop Report

3.4.6.7 Insulation Logs

If the PMC-KR module is equipped for insulation resistance tests, the relay can display the latest 8 test results under the **Insulation Logs** menu.

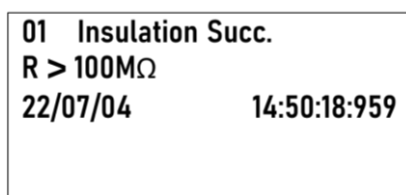

Figure 3-19 Insulation Logs

3.4.7 Setup

The **Setup** menu consists of **System, Protection, Digital Inputs, Digital Outputs, Control, Communication, Analog Outputs, Logic Para.** and **Insulation**. The following sections provide a quick overview of these screens. The **HMI Password** is required for any setup changes. Please refer to **Section 3.4.7.10** for the setup range and default values.

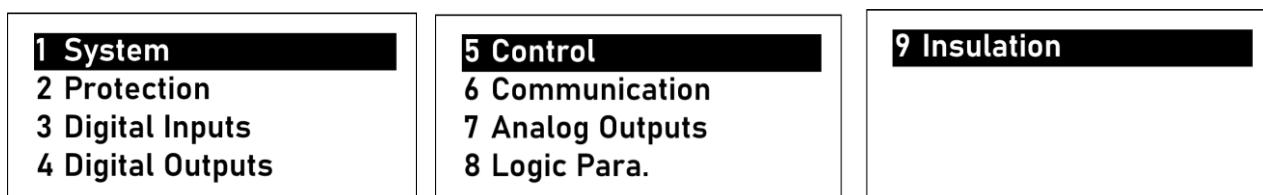

Figure 3-20 Setup menu

3.4.7.1 System

Enter the **System** sub-menu, and the following screens are available.

MTA Connected YES	Primary Ue 100V	Language English
MTA Type 5	Secondary Ue 100V	Ia Polarity Normal
Phase TA Ratio 1	Ctrl Key Emergency	Ib Polarity Normal
Ie 1.0A	DO Remote OFF	Ic Polarity Normal
Voltage Sequence ABC	Insulation MON ON	
Current Sequence ABC	Comm. Ctrl OFF	
PLC ON	QF Block Start OFF	
Temperature MON ON	Test Function OFF	

Figure 3-21 System Setup Screens

3.4.7.2 Protection

Enter the **Protection** sub-menu to configure the Trip/Alarm Reset Mode for all protections, the Pickup, Time Delay, and other settings, and block specific protection when the motor starts.

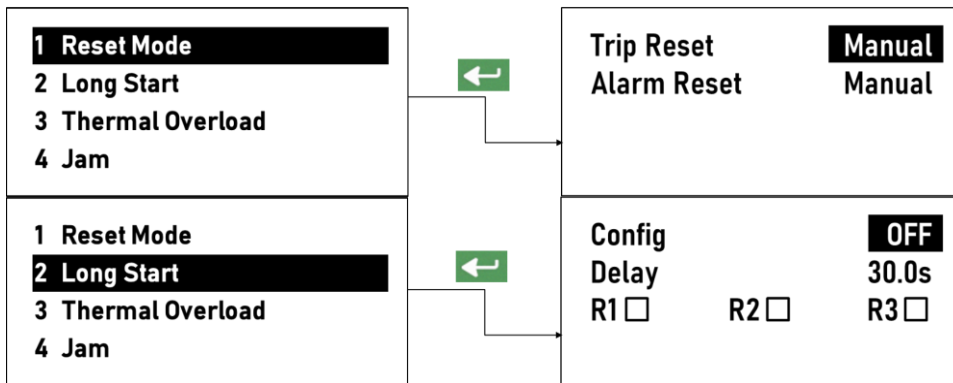

Figure 3-22 Protection Setup Screens

3.4.7.3 Digital Inputs

Enter the **Digital Inputs** sub-menu to configure the **DI Mode**, **Type**, **Debounce Time** and **Excitation** for each DI.

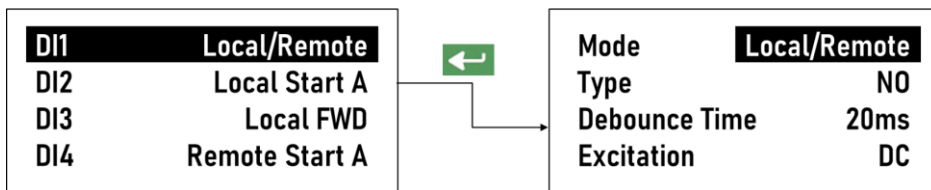

Figure 3-23 Digital Inputs Setup Screens

3.4.7.4 Digital Outputs

Enter the **Digital Outputs** sub-menu to configure the **DO Mode** and **Delay** for each DO.

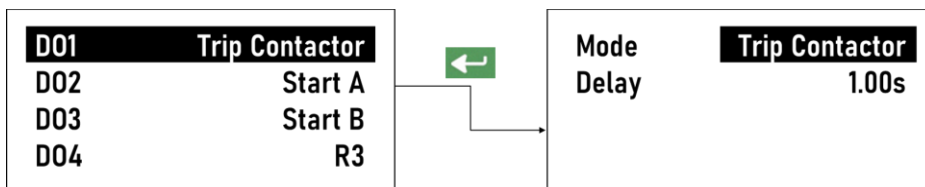

Figure 3-24 Digital Outputs Setup Screens

3.4.7.5 Control

Enter the **Control** sub-menu to configure the parameters for **Undervolt. Restart**, **Restart**, **Device AutoRestart**, **Motor AutoRestart Control**, **Start Control**, **Control Para.**, **Start-Stop Type** and **DP Control**.

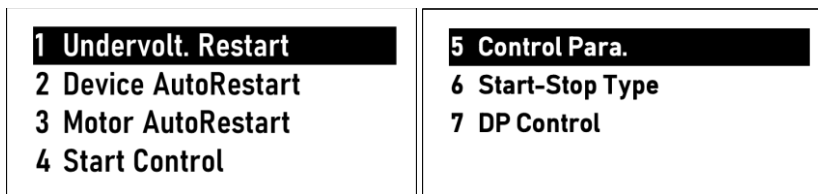

Figure 3-25 Control Setup Screens

3.4.7.6 Communications

Enter the **Communications** sub-menu to configure the parameters for Comm. 1 and Comm. 2.

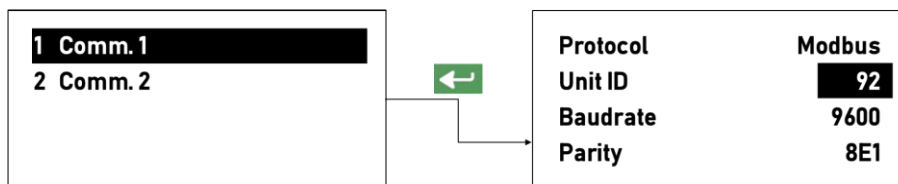

Figure 3-26 Communications Setup Screens

3.4.7.7 Analog Outputs

Enter the **Analog Output** sub-menu, and the following screen is available.

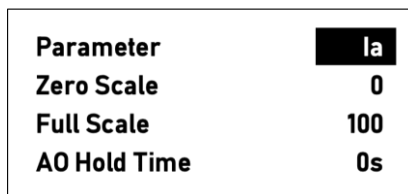

Figure 3-27 Analog Outputs Setup Screen

3.4.7.8 Logic Para.

Enter the **Logic Para.** sub-menu to configure events for programmable logic.



Figure 3-28 Logic Para. Setup Screen

3.4.7.9 Insulation

Enter the **Insulation** sub-menu to configure the insulation monitoring mode (manual/auto) and resistance measuring interval for auto mode.

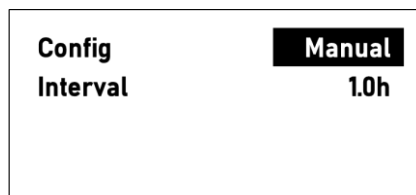

Figure 3-29 Insulation Setup Screen

3.4.7.10 Configuration Parameter

The **Setup** menu provides access to the following setup parameters:

Main Menu			Description	Option/Range, Default*
1 st	2 nd	3 rd		
Password			Enter Password	0000 to 9999, 0000*
System				
MTA Connected			Confirm if the PMC-MTA connected	Yes*, No
MTA Type ¹			The primary rating of the connected PMC-MTA	1 to 5000 (A), 100*
Phase TA Ratio ²			Phase TA ratio, if used	1 to 5000, 1*
Ie ³			Rated motor current	0.1 to 6000.0 (A), 100.0*
Primary Ue			Rated motor voltage (ULL)	100 to 800 (V), 380*
Secondary Ue			Rated relay voltage (ULL)	100 to 800 (V), 380*
Ctrl Key			Specify if the HMI control button is operational under different control modes. See Note 4	Disable*/Emergency/Local/Remote
DO Remote			Specify if the DO needs to be “armed” before execution. ON – need to be “armed” OFF – no need	OFF*, ON
Language			Select the HMI module display language	Chinese, English*
Ia Polarity			Ia Polarity	Normal*/Reverse
Ib Polarity			Ib Polarity	
Ic Polarity			Ic Polarity	
Voltage Sequence			Adjust the Voltage Sequence	ABC*/CBA
Current Sequence			Adjust the Current Sequence	ABC*, CBA, ACB, CAB, BAC, BCA
PLC			Enable Programmable Logic or not	OFF, ON*
Temperature Mon.			Enable PMC-KT module functions (NTC input, DO and DI)	OFF*, ON
Insulation Mon.			Enable insulation monitoring with the PMC-KT module	OFF*, ON
Relay				
Reset Mode ⁵			Specify the generic reset mode for protection (except for Thermal Overload) relay output	
Trip Reset			Specify the reset mode for the relay Trip output	Manual*/Auto
Alarm Reset			Specify the reset mode for the relay Alarm output	Manual/Auto*
Long Start				
Config			Specify the protection output type	OFF*, Trip, Alarm, Trip + Alarm
Delay			Specify the protection active delay	0.10 to 99.99 (s), 30.00*
R1 R2 R3			Select the supplementary output to be linked	N/A
Thermal Overload				
Config			Specify the protection output type	OFF, Trip, Alarm, Trip + Alarm*
Pickup			Specify the protection active threshold (I _{ov})	1.00 to 10.00 (xI _e), 1.00*
Delay			Specify the Heating Time Constant (T _c)	0.10 to 99.99, 6.50*
Cooling			Specify the cooling method after protection returns	Instant, Delay*
Alert Trig.			Specify the Thermal Alert threshold (of operation level)	0 to 99 (%), 0*
Return Threshold			Specify the protection return threshold (valid only when the Cooling method is set to Delay)	0 to 100 (%), 60*
Reset Mode ⁵			Specify the reset mode for protection output	Manual*/Auto
R1 R2 R3			Select the supplementary output to be linked	N/A
Jam				
Config			Specify the protection output type	OFF*, Trip, Alarm, Trip + Alarm
Pickup			Specify the protection active threshold	1.00 to 10.00 (xI _e), 3.50*
Delay			Specify the minimum time duration that the fault condition must be met before the protection becomes active	0.10 to 99.99 (s), 4.00*
R1 R2 R3			Select the supplementary output to be linked	N/A
Ground Fault				
Config			Specify the protection output type	OFF, Trip, Alarm, Trip + Alarm*
Pickup			Specify the protection active threshold	0.10 to 10.00 (xI _e), 1.00*
Run Delay			Specify the minimum time duration that the fault condition must be met before the protection becomes active when the motor is running	0 to 99.99 (s), 0.10*
Start Delay			Specify the minimum time duration that the fault condition must be met before the protection becomes active when the motor is starting	0 to 99.99 (s), 0.50*
R1 R2 R3			Select the supplementary output to be linked	N/A
MTA Failure				
Config			Enable/Disable MTA Failure Alarm	OFF*, ON
Delay			Specify the minimum time duration that the fault condition must be met before the protection becomes active	0.10 to 99.99 (s), 0.50*
R1 R2 R3			Select the supplementary output to be linked	N/A
Phase Current Loss				

Config	Specify the protection output type	OFF, Trip, Alarm, Trip + Alarm*
Delay	Specify the minimum time duration that the fault condition must be met before the protection becomes active	0.10 to 99.99 (s), 2.50*
Block MTA Failure	Block Phase Current Loss element if MTA Failure detected	OFF, ON*
R1 R2 R3	Select the supplementary output to be linked	N/A
Imbalance		
Config	Specify the protection output type	OFF, Trip, Alarm*, Trip + Alarm
Pickup	Specify the protection active threshold	10 to 100 (%), 30*
Delay	Specify the minimum time duration that the fault condition must be met before the protection becomes active	0.10 to 99.99 (s), 5.00*
Block MTA Failure	Block Imbalance element if MTA Failure detected	OFF, ON*
R1 R2 R3	Select the supplementary output to be linked	N/A
Under Power		
Config	Specify the protection output type	OFF*, Trip, Alarm, Trip + Alarm
Pickup	Specify the protection active threshold	-999.9 to 999.9 (kW), 35.0*
Block Value	Low Voltage threshold for blocking the Under Power detection	0.30 to 0.95 (xUe), 0.60*
Delay	Specify the minimum time duration that the fault condition must be met before the protection becomes active	0.50 to 99.99 (s), 5.00*
Reset Delay	Specify the minimum time delay after which the triggered protection trip output will automatically reset	0 to 6000.0 (s), 0*
R1 R2 R3	Select the supplementary output to be linked	N/A
Short Circuit		
Config	Specify the protection output type	OFF, Trip, Alarm, Trip + Alarm*
Pickup ⁶	Specify the protection active threshold	1.00 to 10.00 (xIe), 7.50*
Delay	Specify the minimum time duration that the fault condition must be met before the protection becomes active	0 to 99.99 (s), 0*
Start Multiple ⁶	Specify the Start Multiple to decrease the fault detection sensitivity in the motor start period	1.00 to 2.00, 1.00*
R1 R2 R3	Select the supplementary output to be linked	N/A
Undervoltage		
Config	Specify the protection output type	OFF*, Trip, Alarm, Trip + Alarm
Pickup	Specify the protection active threshold	0.30 to 0.95 (xUe), 0.45*
Delay	Specify the minimum time duration that the fault condition must be met before the protection becomes active	0.10 to 99.99 (s), 9.00*
No_I Lock	Lock/Unlock Undervoltage protection when $I_e=0$ detected	OFF, ON*
Reset Delay	Specify the minimum time delay after which the triggered protection trip output will automatically reset	0 to 6000.0 (s), 0*
R1 R2 R3	Select the supplementary output to be linked	N/A
Overvoltage		
Config	Specify the protection output type	OFF*, Trip, Alarm, Trip + Alarm
Pickup	Specify the protection active threshold	1.05 to 1.60 (xUe), 1.20*
Delay	Specify the minimum time duration that the fault condition must be met before the protection becomes active	0.10 to 99.99 (s), 4.00*
R1 R2 R3	Select the supplementary output to be linked	N/A
Underload		
Config	Specify the protection output type	OFF*, Trip, Alarm, Trip + Alarm
Pickup	Specify the protection active threshold	0.10 to 1.00 (xIe), 0.40*
Delay	Specify the minimum time duration that the fault condition must be met before the protection becomes active	1 to 9999 (s), 20*
Reset Delay	Specify the minimum time delay after which the triggered protection trip output will automatically reset	0 to 6000.0 (s), 0*
R1 R2 R3	Select the supplementary output to be linked	N/A
tE Time		
Config	Specify the protection output type	OFF*, Trip, Alarm, Trip + Alarm
Delay	Specify the time constant Tp	0.01 to 99.99 (s), 6.00*
R1 R2 R3	Select the supplementary output to be linked	N/A
Overload		
Config	Specify the protection output type	OFF*, Trip, Alarm, Trip + Alarm
Pickup	Specify the protection active threshold	1.00 to 10.00 (xIe), 1.20*
Delay	Specify the minimum time duration that the fault condition must be met before the protection becomes active	0.10 to 99.99 (s), 30.00*
R1 R2 R3	Select the supplementary output to be linked	N/A
Interlock		
Config	Specify the protection output type	OFF*, Trip, Alarm, Trip + Alarm
Delay	Specify the minimum time duration that the fault condition must be met before the protection becomes active	0 to 99.99 (s), 0.20*
R1 R2 R3	Select the supplementary output to be linked	N/A

Thermo		
Config	Specify the protection output type	OFF*, Trip, Alarm, Trip + Alarm
Type	Select the Thermo sensor type	PTC*, NTC, Mix
Upper Limit	Specify the active limit for PTC thermal resistance or inactive limit for NTC thermal resistance protection	0.10 to 30.00 (kΩ), 10.00*
Lower Limit	Specify the inactive limit for PTC thermal resistance or active limit for NTC thermal resistance protection	0.10 to 30.00 (kΩ), 8.00*
Delay	Specify the minimum time duration that the fault condition must be met before the protection becomes active	0.10 to 99.99 (s), 2.00*
Short cct. ALM	Enable/disable the alarm for thermal resistance short circuit	OFF*, ON
Open cct. ALM	Enable/disable the alarm for thermal resistance open circuit	OFF*, ON
R1 R2 R3	Select the supplementary output to be linked	N/A
LOP		
Config	Enable/Disable Loss of Phase alarm	OFF, ON*
R1 R2 R3	Select the supplementary output to be linked	N/A
Phase Reversal		
Config	Specify the protection output type	OFF*, Trip, Alarm, Trip + Alarm
R1 R2 R3	Select the supplementary output to be linked	N/A
Closed-loop Abnormal		
Config	Specify the protection output type	OFF*, Trip, Alarm, Trip + Alarm
Delay	Specify the minimum time duration that the fault condition must be met before the protection becomes active	0.1 to 99.99 (s), 1.00*
R1 R2 R3	Select the supplementary output to be linked	N/A
Contactor		
Config	Enable/disable contactor protection	OFF*, ON
Pickup	Contactor maximum breaking capacity	4.00 to 20.00 (xIe), 8.00*
Contactor Failure		
Config	Enable/disable the contactor failure alarm	OFF*, ON
Pickup	Specify the protection active threshold	0.10 to 5.00 (xIe), 0.30*
Delay	Specify the minimum time duration that the fault condition must be met before the protection becomes active	0.10 to 99.99 (s), 0.50*
Stop Trigger	Enable/Disable Contactor Failure protection after the motor stop command sent	OFF, ON*
R1 R2 R3	Select the supplementary output to be linked	N/A
ACB Trip Contactor		
Config	Enable/disable the air circuit breaker (ACB) trip contactor feature	OFF*, ON
Delay	Specify the minimum time duration that the fault condition must be met before the protection becomes active	0.10 to 99.99 (s), 1.00*
Contactor Abnormal		
Config	Specify the protection output type	OFF*, Trip, Alarm, Trip + Alarm
Delay	Specify the minimum time duration that the fault condition must be met before the protection becomes active	0.10 to 99.99 (s), 5.00*
R1 R2 R3	Select the supplementary output to be linked	N/A
Emergency Stop Alarm		
Config	Enable/disable the emergency stop alarm	OFF*, ON
R1 R2 R3	Select the supplementary output to be linked	N/A
Residual-I (I)		
Config	Specify the protection output type	OFF*, Trip, Alarm, Trip + Alarm
Pickup	Specify the protection active threshold	20 to 5000 (mA), 300*
Delay	Specify the minimum time duration that the fault condition must be met before the protection becomes active	0.00 to 99.99 (s), 5.00*
Start Multiple	Specify the start multiple to decrease the fault detection sensitivity in the motor start period	1.00 to 2.00, 1.00*
R1 R2 R3	Select the supplementary output to be linked	N/A
Residual-I (II)		
Config	Specify the protection output type	OFF*, Trip, Alarm, Trip + Alarm
Pickup	Specify the protection active threshold	20 to 5000 (mA), 500*
Delay	Specify the minimum time duration that the fault condition must be met before the protection becomes active	0.00 to 99.99 (s), 1.00*
Start Multiple	Specify the start multiple to decrease the fault detection sensitivity in the motor start period	1.00 to 2.00, 1.00*
R1 R2 R3	Select the supplementary output to be linked	N/A
Negative Sequence		
Config	Specify the protection output type	OFF*, Trip, Alarm, Trip + Alarm
Pickup	Specify the protection active threshold	0.10 to 10.00 (Ie), 1.20*

Run Delay	Specify the minimum time duration that the fault condition must be met before the protection becomes active when the motor is running	0.10 to 99.99 (s), 2.00*
Start Delay	Specify the minimum time duration that the fault condition must be met before the protection becomes active when the motor is starting	0.10 to 99.99 (s), 4.00*
R1 R2 R3	Select the supplementary output to be linked	N/A
Block When Start		
Block Time	Specify the block time for the inhibited protection	0 to 99.99 (s), 10.00*
Select	Check/Uncheck on specified protection during motor start	See Note 7, N/A
TC1 I		
Config	Specify the protection output type	OFF*, Trip, Alarm, Trip + Alarm
Pickup	Specify the protection active threshold	20.0 to 150.0 (°C), 70.0*
Delay	Specify the minimum time duration that the fault condition must be met before the protection becomes active	0.00 to 99.99 (s), 2.00*
R1 R2 R3	Select the supplementary output to be linked	N/A
TC1 II		
Config	Specify the protection output type	OFF*, Trip, Alarm, Trip + Alarm
Pickup	Specify the protection active threshold	20.0 to 150.0 (°C), 100.0*
Delay	Specify the minimum time duration that the fault condition must be met before the protection becomes active	0.00 to 99.99 (s), 2.00*
R1 R2 R3	Select the supplementary output to be linked	N/A
...		
TC6 I		
...	See TC1 I above	
TC6 II		
...	See TC1 II above	
Insulation		
Config	Specify the protection output type	OFF*, Trip, Alarm, Trip + Alarm
Pickup	Specify the protection active threshold	0.1 to 50.0 (MΩ), 1.0*
R1 R2 R3	Select the supplementary output to be linked	N/A
Digital Inputs		
DI1 to DI12		
Mode	Specify the DI function based on the application	See Note 8, Common State*
Type	Specify the de-energized position for the contacts of a certain DI. NO – Normally Open, NC – Normally Closed.	NO*, NC
Debounce Time	Specify the minimum duration the DI must remain in the active or inactive state before a state change is considered to be valid.	20 to 9999 (ms), 40*
Excitation	Specify the excited mode for each DI.	DC*, AC, External
Digital Output		
DO1 to DO6		
Mode	Specify the DO function based on the application	See Note 9
Delay	Specify the duration for which the digital output will be inactive when a release command is received	0.00 to 99.99 (s), 1.00*
Control		
Undervolt. Restart		
Config	Enable/disable the Undervoltage restart control	OFF*, ON
Quick Start t	Allowable duration for a short voltage dip. If the voltage recovers within this time, the motor can automatically restart.	0 to 9.99 (s), 2.50*
Preset DO Close	ON – Keep the contact of the motor start DO closed during the short voltage dip without checking if the voltage has been restored. OFF – The motor start DO will close automatically when the voltage is restored.	ON*, OFF
Pulse Width	In duration of Voltage Dip event, if you want the motor running DO signal to remain closed throughout the dip duration, the Pulse Width of this DO has to be greater than or equal to the Quick Start Time.	0 to 30.00 (s), 0.10*
Restart Delay	Minimum delay in restarting the motor after the voltage is restored.	0.1 to 999.9 (s), 0.2*
Allowed Time	The allowable time for Undervoltage Restart. This time must be longer than the sum of the Quick Start t and Restart Delay. If the voltage recovers within this time window, the motor can restart with the Undervoltage Restart logic.	0.5 to 999.9 (s), 20.0*
Dip Threshold	Voltage magnitude indicating the start of a voltage dip	0.30 to 0.95 (xUe), 0.75*
Recover Volt.	Voltage magnitude indicating the end of a voltage dip	0.80 to 1.60 (xUe), 0.85*
Aux. DO	In soft-starter combined control applications, the auxiliary DO offers a reset signal before restarting the soft-starter if needed.	N/A*, DO1 to DO6

Aux. DO Delay	Delay in operating the auxiliary DO after the voltage is restored	0 to 99.99 (s), 0*
Block Time	During the block time, the relay will inhibit all Undervoltage Restart commands.	0 to 99.99 (s), 0*
Device AutoRestart		
Config	Enable/disable the device auto-restart feature	OFF*, ON
Mode	Restart – Restart the motor, regardless of its previous state, before the voltage interruption. Recover – Restart the motor and recover it to the previous state (e.g., forwarding, reversing) before the voltage interruption.	Restart, Recover*
Delay	Delay in restarting or restoring the motor to the previous state after the system voltage is restored	0.10 to 99.99 (s), 0.10*
Motor AutoRestart		
Config	Enable/disable the motor auto-restart control	ON, OFF*
Mode	Restart – Restart the motor, regardless of its previous state, before the voltage interruption. Recover – Restart the motor and recover it to the previous state (e.g., forwarding, reversing) before the voltage interruption.	Restart, Recover*
Delay	Delay in restarting or restoring the motor to the previous state after the motor voltage is restored	0.1 to 999.9 (s), 25.0*
Start Control		
Start Lock t	Specify the minimum time window between motor starts	0 to 9999 (s), 0* (0 means disabled)
Stop Lock t	Specify the waiting time after the motor was stopped or tripped that has to pass until a safe restart is possible	0 to 9999 (s), 0* (0 means disabled)
Max. Start Count	Specify the maximum number of starts in a defined interval	0 to 20, 0* (0 means disabled)
Interval	Specify the time window during which if the Max. Start Count is reached, any additional start request will be ignored	1 to 9999 (min), 30*
Control Para.		
Mode	Select the starter type based on the application and wiring	See Note 10
Start-Stop Type		
Stop DI Trig.	Specify the Trip output mode for DI Stop Command	Latched*, Pulse
CMD Mode	Specify the signal type for a DI Start/Stop signal to become active	Edge Trigger*, Level Trigger
DP Control**		
Config	ON – PROFIBUS DP communication interruption will cause motor stop OFF – PROFIBUS DP communication interruption has no effect on the motor running	OFF*, ON
Communications		
RS-485		
Unit ID	Set RS-485 Unit ID	1 to 247
Baudrate	Set RS-485 Baudrate (bps)	1200, 2400, 4800, 9600*, 19200
Parity	Set RS-485 Parity	8N2, 8O1, 8E1*, 8N1, 9O2, 8E2
DP (optional)		
Unit ID	Set PROFIBUS DP Unit ID	1 to 125, 1*
Baudrate	Set PROFIBUS DP Baudrate (kbps)	9.6, 19.2, 45.45, 93.75, 183.7, 500, 1500*
MODBUS TCP (optional)		
Check ID	Enable Unit ID verification or not	YES, NO*
Unit ID	Specify the MODBUS TCP Unit ID	1 to 247
IP (optional)		
Mode	Specify the working mode for dual Ethernet ports	Normal*, Switch
IP1	IP Address for Ethernet Port 1	192.168.0.100*
MASK1	Subnet Mask for Ethernet Port 1	255.255.255.0
IP2	IP Address for Ethernet Port 2	192.168.1.100
MASK2	Subnet Mask for Ethernet Port 2	255.255.255.0
Gateway	Gateway IP	192.168.0.1
SNTP (optional)		
Server	IP Address for SNTP Server	127.0.0.1
Update Rate	Interval for Time Synchronization with SNTP Server	0 to 9999 (min), 1*
UTC Offset	Time Differences between Local Time and UTC Time	-720 to 780 (min), 480* (UTC +8)
Analog Output		
Parameter	Specify the parameter to which the Analog Output is proportional	Ia*, Ib, Ic, P, IR, 3I0, Iavg, Ullavg, VARA1
Zero Scale	Specify the zero-scale value of the parameter when the Analog Output is 4mA	-999,999 to 999,999, 40*

Full Scale	Specify the full-scale value of the parameter when the Analog output is 20mA	-999,999 to 999,999, 200*
AO Hold Time	Specify the period for which the AO maintains stable power and valid control signals after main power failure.	0-50 (x0.1s), 0* (0 means that the relay will stop the analog output signal immediately if power is lost)
Logic Para.		
VARx	Specify the variable for the programmable logic function.	0-65535, 0*
Insulation		
Config	Specify the working mode of the insulation test	OFF*, Manual, Auto
Interval	Specify the automatic testing interval for the insulation test	1 to 30000 (x0.1h), 10*

Table 3-4 HMI Module Configuration Parameters

Notes:

- The following table illustrates the recommended PMC-MTA type based on the rated Current and Power.

MTA Type	Rated kW	Rated Current
PMC-MTA-1A	< 0.4 kW	0.2 to 1 A
PMC-MTA-5A	0.4 to 2.2 kW	1 to 5 A
PMC-MTA-25A	2.2 to 12.5 kW	5 to 25 A
PMC-MTA-100A	12.5 to 50 kW	25 to 100 A
PMC-MTA-300A	50 to 150 kW	100 to 300 A
PMC-MTA-400A-T	120 to 200 kW	240 to 400 A
PMC-MTA-800A-T	160 to 400 kW	320 to 800 A

Table 3-5 Recommended PMC-MTA Type

- In some applications, it is required to use an additional protection current transformer (TA) transforms the circuit current to the relay's PMC-MTA Input. And the **Phase TA Ratio** should be set based on the Primary and Secondary of the protection current transformer. For example, to protect an LV motor rated at 500kW, 1200A, the Primary Input and Secondary Output of the used protection current transformer can be 1200A and 5A, respectively. The **Phase TA Ratio** should be set as (1200A/5A) = 240. Please note that **MTA Type x Phase TA Ratio** ≤ 5000.
- The following table illustrates that the motor rated Current **Ie** has a setting range based on **Z = MTA Type x Phase TA Ratio**.

Z	Ie Setting Range
< 100	0.1 – 1.2 (*Z)
≥ 100	0.2 – 1.2 (*Z)

Table 3-6 Motor Rated Current Ie Setting Range

- The user can use the push buttons on the HMI module to start/stop the motor based on the **Control Key** and **DI Local/Remote** control switch settings. If the **Control Key** is set to **Disable**, the push buttons are not operational. **Control Key** set to **Emergency** means the push button control is always valid regardless of the **DI Local/Remote** setting. And under other circumstances, the **Control Key** setting has to be consistent with the **DI Local/Remote** to make the push buttons functional. If none of the DI is configured as **Local/Remote** control switch, the **Control Key** has to be set to **Local** so that the HMI button control can make sense.
- For the **Auto** reset type, the protection trip/alarm is acknowledged without the intervention of a human operator if the fault is removed. For the **Manual** reset type, the protection trip/alarm must be acknowledged by the user via the Reset button on the HMI module, DI Reset Protection control signal, or communications. **Manual** reset is used in applications and processes demanding safety checks before the starting process. In such an application, human intervention is the final check.
- For short circuit protection, **Pickup x Start Multiple** ≤ 10 x **MTA Type x TA Ratio**.
- The following protection can be blocked since the motor start is detected.

Bit	Protection	Bit	Protection	Bit	Protection	Bit	Protection
0	Thermal Overload	4	Imbalance	8	tE Time	12	Residual Current level I
1	Jam	5	Under Power	9	Overload	13	Residual Current level II
2	Ground Fault	6	Short Circuit	10	Interlock	14	Negative Sequence
3	Phase Current Loss	7	Underload	11	Phase Reversal		

Table 3-7 Protections To Be Blocked when Motor Start

- The following table illustrates all the available options for DI Mode.

No.	Option	No.	Option	No.	Option	No.	Option
0	Common State	8	Local Start B	16	Remote FWD	24	Position
1	Local/Remote	9	KMA State	17	Remote REV	25	Open Limit Signal
2	Interlock	10	KMB State	18	Emergency Start A	26	Close Limit Signal
3	Stop	11	QF State	19	Emergency Start B	27	Open Over Torque
4	Emergency Stop	12	Start Block	20	Local FWD	28	Close Over Torque
5	Remote Start A	13	Remote Stop	21	Local REV		
6	Remote Start B	14	Local Stop	22	FWD		
7	Local Start A	15	Reset Protection	23	REV		

Table 3-8 DI Mode Options

- The following table illustrates all the available options for DO Mode.

No.	Option	No.	Option	No.	Option	No.	Option
0	Spare	3	Start A	6	Trip Air Circuit Breaker	9	R2
1	Trip Contactor	4	Start B	7	Trip Cooler/S-Motor	10	R3
2	Self-check	5	Alarm	8	R1	11	Motor Running

Table 3-9 DO Mode Options

The default setting for DO1 to DO6 (DO6 is valid only when the PMC-KT module is equipped and enabled) Mode are:

DO1=Trip Contactor, DO2=Self-check , DO3=Start A, DO4=Trip ACB, DO5=Alarm, DO6=Spare

10. The following table illustrates the configuration parameters under different Starter modes.

Setting Parameter	Specifications/Definitions/Range	Default	
Mode	Defines the starter function based on the applications. Direct-On-Line, Reduce-volt., FWD/REV Start, 2-Speed Start, Inverter Coordinated Control, High-power Motor Auxiliary Control, Circuit Breaker Control, Motorized Valve Control	Direct-On-Line	
CMD mode	0=Edge Trigger*, 1=Level Trigger	0=Edge Trigger	
DP control config	Enable/disable auto-stop on DP communication loss. 0=Off*, 1=On	0=Off	
DP control delay	Delay time before stopping after DP communication loss. 1-9999 (x0.1s)	50	
Reduce-voltage Start (Including Star-Delta Start, Auto-transformer Start and Resistance Start)			
Delay	Delay in switching the motor to full-voltage running from the Reduce-voltage start. The switch over from reduce-volt. start to full-volt. running takes place earliest after 1s delay, therefore, the delay must be set to at least 1 second. 1.00 to 99.99 (s)	25.00	
Iset	Specify the max. allowable current for Reduce-voltage start period. If Iset=0, the motor switches to full-volt. running from Reduce-voltage start once the Delay time is reached. 0.00 to 3.00 (xIe)	0	
Mode	In make-before-break (MBB) mode, DO Start A (Reduce-voltage) maintains closed until DO Start B (full-voltage) operates. While in break-before-make (BBM) mode, DO Start B operates after 1s delay since the DO Start A released. If motor Ie < 0 (Ie ≠ 0) is detected after DO Start A released, the relay will alarm that the Reduce-voltage start is failed. Please note that make-before-break mode shall NOT be used in Star-Delta start. MBB, BBM	BBM	
FWD/REV Start			
Delay	Specify the minimum time before a start in the opposite direction is possible. 1.00 to 99.99 (s)	5.00	
2-Speed Start			
I1	Nominal current of motor for speed 1. 0.20 to 5.00 (xIe),	1.00	
I2	Nominal current of motor for speed 2. 0.20 to 5.00 (xIe)	0.50	
Delay	Specify the minimum time before a start at alternative speed is possible. 1.00 to 99.99 (s)	5.00	
Inverter Coordinated Control			
Delay	Defines the startup delay time for inverter coordinated control. 1-99.99 s	10	
High-power Motor Auxiliary Control			
Start control	Start block time	Start interval for sequential motor starting control. 0-9999 (s), (0 means disabled)	0
	Stop block time	Start-stop interval for sequential motor starting control. 0-9999 (s), (0 means disabled)	0
	Max. start count	Max consecutive starts for sequential motor control. 0-20, (0 means disabled)	0
	Interval	Start interval for sequential motor starting control. 1-9999 (min)	30
Delay	Start delay for large motor auxiliary control. 1-99.99 s	10	
Motorized Value Control			
Control Timeout	Control timeout for motorized valve operation. 0.1-6000 s	20	
Start Timeout	Startup timeout for motorized valve control. 0.1-6000 s	8	
DI Emergency	Enable/disable emergency motorized valve control via DI. 0=Off, 1=On	0=Off	

Table 3-10 Different Starter Mode Configuration Parameters

3.4.8 Statistics

Enter the **Statistics** menu, and the following screens are available.

Trip IA 0.000A Trip IB 0.000A Trip IC 0.000A Trip Times 0	Start I 1.210A Start Time 0.12s Start Count 22	Total Running Time 20h Running Time 2h
Total Stop Time 1759h Stop Time 139h	Device Running Time 1800h Insulation R 60.05MΩ	

Figure 3-30 Statistics Screens

3.4.9 Maint.

The **Maint.** menu consists of **Comm. Test, Control Logic Test, Date/Time, Change Password, Clear Data, Insulation, Diagnosis, Backlight Timeout, LCD Contrast, Preset Energy, Manual WFR Trigger, Para. Config** and **Key Test**. The following sections provide a quick overview of these screens. The **HMI module Password** is required for any maintenance operation.

1 Comm. Test 2 Control Logic Test 3 Date/Time 4 Change Password	5 Clear Data 6 Insulation 7 Diagnosis 8 Backlight Timeout	9 LCD Contrast 10 Preset Energy 11 Manual WFR Trigger 12 Para. Config
13 Key Test		

Figure 3-31 Maintenance menu

3.4.9.1 Comm. Test

Enter the **Comm. Test** sub-menu, and the following screens are available. Enter a specific item, and the corresponding data for this sub-menu will be uploaded to the workstation/master for the communication test.

1 Relay Data 2 Metering Data 3 Harmonic 4 Temperature	5 DI Status 6 DO Status 7 Prot. Status
---	---

Figure 3-32 Comm. Test

3.4.9.2 Control Logic Test

Enter the **Control Logic Test** sub-menu, and the following screens are available. Enter a specific item to perform the corresponding control logic test.

1 DI 2 DO 3 Protection

Figure 3-33 Control Logic Test

3.4.9.3 Date/Time

Enter the **Date/Time** sub-menu, and the following screen is available.

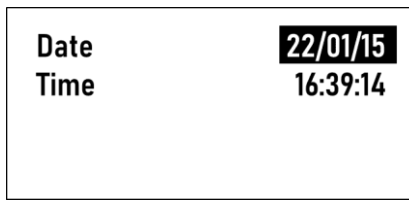

Figure 3-34 Date/Time

3.4.9.4 Change Password

Enter the **Change Password** sub-menu to setup a new HMI password.

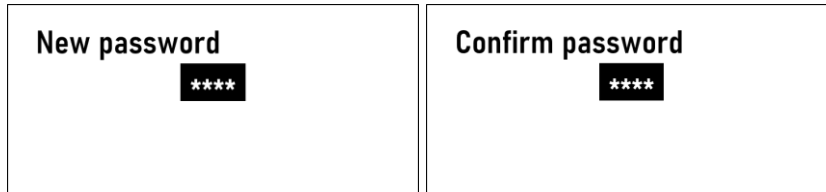

Figure 3-35 Change Password

3.4.9.5 Clear Data

Enter the **Clear Data** sub-menu, and the following screens are available.

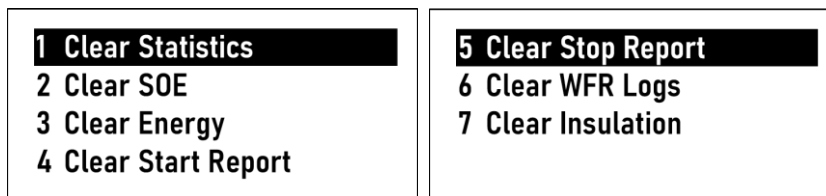

Figure 3-36 Clear Data

3.4.9.6 Insulation

Enter the Insulation sub-menu to start and stop the insulation test manually.

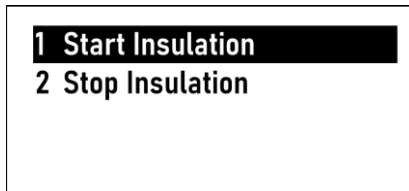

Figure 3-37 Insulation Test

3.4.9.7 Diagnosis

Enter the **Diagnosis** sub-menu; the following screen displays the Voltage and Current Polarity.

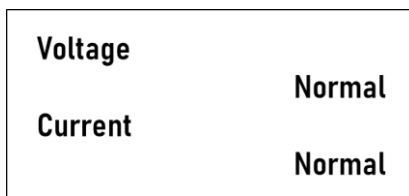

Figure 3-38 Diagnosis

3.4.9.8 Backlight Timeout

Enter the **Backlight Timeout** sub-menu to adjust the LCD timeout.



Figure 3-39 Backlight Timeout

3.4.9.9 LCD Contrast

Enter the **LCD Contrast** sub-menu, and the following screen is available.



Figure 3-40 LCD Contrast

3.4.9.10 Preset Energy

Enter the **Preset Energy** sub-menu to preset the kWh Import/Export and kvarh Import/Export.



Figure 3-41 Preset Energy

3.4.9.11 Manual WFR Trigger

Enter the **Manual WFR Trigger** sub-menu to trigger a waveform recording.



Figure 3-42 Manual WFR Trigger

3.4.9.12 Para. Config

Enter the **Para. Config** sub-menu to define the parameters type.

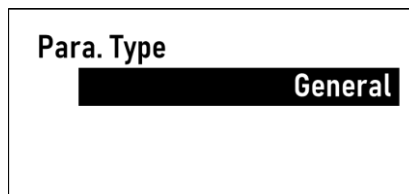

Figure 3-43 Para. Config

3.4.10 Info.

Enter **Info.** menu to access the information for the Host (PMC-550D relay), HMI, Temperature MON (PMC-KT module) and Insulation MON (PMC-KR module).

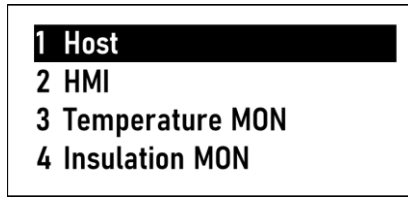

Figure 3-44 Info. menu

3.4.10.1 Host

Enter the **Host** menu to access the following information.

Firmware	V3.00.05	PLC Version	V1.01
Modbus	V3.1		
Date	22.03.14		
S/N	1003696792		

Figure 3-45 Info.

3.4.10.2 HMI

Enter the **HMI** menu to access the following information.

Firmware	V2.00.03
Date	22.12.20
HW Match	YES

Figure 3-46 HMI Info.

3.4.10.3 Temperature MON

Enter the **Temperature MON** menu to access the following information.

Temperature MON	
Firmware	V1.00.02
Date	22.06.14
S/N	3301020211

Figure 3-47 PMC-KT Module Info.

3.4.10.4 Insulation MON

Enter the **Insulation MON** submenu to access the following information.

Insulation MON	
Firmware	V1.00.02
Date	22.06.14
S/N	3301020161

Figure 3-48 PMC-KR Module Info.

Chapter 4 Applications

4.1 Digital Inputs

The PMC-550D comes with ten Digital Inputs, which support being either internally or externally wetted based on the model option selected. As an option, the relay can be expanded with two additional DIs with the PMC-KT module.

4.1.1 Configurations

The following table describes the available setting parameters for Digital Inputs.

Parameters	Functions/Descriptions	Options/Default*
Dlx Mode (x=1 to 12)	Each DI can be configured as a Common State, Status Input, or Control Signal Input (See Table 4-2).	Common State*
Dlx Type	Specify the de-energized position for the contacts of a DI. NO – Normally Open, NC – Normally Closed.	NO*, NC
Debounce Time	Specify the minimum duration the DI must remain in the Active or Inactive state before a state change is considered to be valid.	20 to 9999 (ms), 40*
Dlx Excitation	Specify the excited mode for each DI.	DC*, AC, External

Table 4-1 DI Setup Parameters

Notes:

- For internally wetted DI, the Excitation mode must be DC. However, if the user wishes to use 110VAC/DC or 220VAC/DC voltage with a PMC-KI module to excite the DI, the DI Excitation mode must be External. For externally excited DI, the Excitation mode must be AC.

4.1.2 DI Mode

The relay provides the following programmable functions for its Digital Inputs. The two DIs on the PMC-KT module can only be configured as **Common State**, **QF State**, **Reset Protection**, and **State**.

DI Mode	Functions/Descriptions
Common State	Common status monitoring. This mode doesn't apply to any protection or control element.
Status Input	
Local/Remote	Local and remote control switch. See Note 1.
Interlock	External control signal input. See Interlock Protection.
KMA State	The DI configured as KMA state connects to the auxiliary contacts of a contactor controlling the motor. The DI status indicates the contactor coil status, with "1" meaning energized and "0" meaning de-energized. Besides, in Large Motor control applications, this DI shall connect to the large motor circuit for status monitoring. Only one DI shall be configured as KMA State.
KMB State	The DI configured as KMB state connects to the auxiliary contacts of a contactor in a different position from the KMA contactor. The DI status indicates the contactor coil status, with "1" meaning energized and "0" meaning de-energized. Besides, in Large Motor control applications, this DI shall connect to the small motor circuit for status monitoring. Only one DI shall be configured as KMB State.
QF State	Status input for air circuit breaker. Only one DI can be configured as QF State.
State	Signal input for the relay's working state. 0 – working, 1 – testing.
Control Signal Input	
Emergency Stop	An Emergency Stop operation occurs irrespective of the control mode.
Stop	Common Stop operation occurs irrespective of the control mode.
Remote Stop	Stop operation valid only when the control mode is Remote.
Local Stop	Stop operation valid only when the control mode is Local.
Remote Start A	Start A operation valid only when the control mode is Remote.
Remote Start B	Start B operation valid only when the control mode is Remote.
Local Start A	Start A operation valid only when the control mode is Local.
Local Start B	Start B operation valid only when the control mode is Local.
Remote FWD	Forward/Speed 1 Start-Stop operation valid only when the control mode is Remote.
Remote REV	Reverse/Speed 2 Start-Stop operation valid only when the control mode is Remote.
Start Block	Block all the start signal inputs according to the applications.
Reset Protection	Reset trip or alarm output contact for protection.
Emergency Start A	Emergency Start A operation occurs irrespective of the control mode.
Emergency Start B	Emergency Start B operation occurs irrespective of the control mode.
Local FWD	Forward/Speed 1 Start-Stop operation valid only when the control mode is Local.
Local REV	Reverse/Speed 2 Start-Stop operation valid only when the control mode is Local.

FWD	Forward/Speed 1 Start-Stop operation irrespective of the control mode.
REV	Reverse/Speed 2 Start-Stop operation irrespective of the control mode.

Table 4-2 DI Mode Options

Notes:

1. A de-energized position of DI contacts configured to **Local/Remote** control switch stands for **Local Control** mode, while an energized position means **Remote Control**.
2. The Emergency Start control signal is valid only when Thermal Overload protection trips. See **Section 4.4.4.5.6**.
3. In **Forward-Reverse** and **2-speed** start, if the motor is already running in a certain direction or speed, it requires a stop signal before an opposite or alternative speed operation. For DI configured to (Local/Remote) FWD or REV, a non-zero value means Forward or Reverse (at speed 1 or speed 2 in 2-speed control) while a zero-value means stop.
4. The (Local/Remote) REV control signals are only valid in forward-reverse or 2-speed control modes.
5. The following table describes the definitions for DI Start A and Start B control signals with different Starter functions based on the schematic diagrams in **Section 2.19**.

Starter Functions	DI Signals	
	Start A	Start B
Direct-On-Line	Start	-- (Not used)
Reduce-voltage	Reduce-voltage start	Full-voltage running
Forward-reverse	Forward	Reverse
2-speed	Speed 1	Speed 2
VFD start	Start VFD	-- (Not used)
L-Motor start	Start Large Motor	-- (Not used)

Table 4-3 Definitions for DI Start A/Start B signals under various Starter Functions

4.2 Digital/Relay Outputs

4.2.1 DO Mode

The Digital Outputs on the relay can be mapped to various protection (trip and alarm) and general-purpose control elements as the following description.

- 1) Trip Contactor Link to protection trip signal. The DO1 is set as Trip Contactor with factory configurations. As a fault output, providing **Trip Reset = Manual** (See **Section 4.4.3**), once the trip condition has cleared, the DO requires a manual reset via the HMI module, **DI Reset Protection**, or through communications to return to inactive state from the active state, regardless the **DO Delay** setting. While in **Auto** reset mode, once the trip condition is removed, the DO will automatically return to an inactive state after a time equal to **DO Delay**. Optionally, the **Trip Contactor** output can be used for motor stop control. In this condition, the DO must be released by the timer (**DO Delay**).
- 2) Self-check The DO configured for **Self-check** shall connect to the contactor controlling motor ON/OFF (usually select DO2 with NC type for Self-check output). The contact for Self-check DO will release to break the motor circuit when a self-check error occurs (see Appendix A for the self-check type details). The **DO Delay** should be set to **Latched** mode (i.e., Delay = 0).
- 3) Start A The DO Start A links to different start operations depending on the Starter functions (see **Table 4-5**). The DO3 is configured as Start A by default. To use the same DO for start and stop control, the **DO Delay** should be set to **Latched** mode (i.e., Delay = 0).
- 4) Start B The DO Start B links to different start operations depending on the Starter functions (see **Table 4-5**). To use the same DO for start and stop control, the **DO Delay** should be set to **Latched** mode (i.e., Delay = 0).
- 5) Alarm Link to the protection alarm signal. The DO5 is configured as an Alarm output by default for selected protection elements such as Thermal Overload, Ground Fault, and Short Circuit. As a fault output, providing **Alarm Reset = Manual** (See **Section 4.4.3**), once the alarm condition has cleared, the DO requires a manual reset via the HMI module, **DI Reset Protection**, or through communications to return to inactive state from active state, regardless the **DO Delay** setting. While in **Auto** reset mode, once the alarm condition is removed, the DO will automatically return to an inactive state after a time equal to **DO Delay**.

- 6) Trip ACB The DO configured as Trip ACB (Air Circuit Breaker) is connected to the shunt trip coil of the air circuit breaker. The DO4 is configured as Trip ACB by default for Contactor protection and Contactor Failure protection elements.
- 7) Trip Cooler/S-Motor During VFD (Variable Frequency Drive) start process, the DO with such configuration will trip the cooler. And in the Large Motor start process, the DO with such a configuration will trip the small Motor.
- 8) R1/R2/R3 Supplementary outputs. Every protection may be allocated with R1, R2, R3, or a combination thereof. When the protection operates, the DO configured as supplementary output will act without affecting the trip or alarm output.
- 9) Motor Running Connected to the DCS system to indicate the motor running state. The DO for Motor Running (usually NO type) is energized when the motor is running. If a motor stops due to a short voltage dip, the output can be optionally closed during the voltage dip (see **Pulse Width** parameter definition in **Section 4.6**).

4.2.2 Parameters

The following table describes the general setting parameters for Digital Output.

Setting Parameter	Range	Default
DOx Mode	0=Spare, 1=Trip Contactor, 2=Self-check, 3=Start A, 4=Start B, 5=Alarm, 6=Trip Air Circuit Breaker, 7=Trip Cooler/S-Motor, 8=R1, 9=R2, 10=R3, 11=Motor Running	DO1=1, DO2=2, DO3=3, DO4=6, DO5=5, DO6=0
DOx Delay	0.00 to 99.99 (s)	1.00

Table 4-4 Digital Output Setting Parameters

Notes:

- Depending on the Delay setting, the DO may behave differently. For **Latched** operation (**Delay = 0**), the DO will remain active since it is operated and will only return to an inactive state since manually released. For **Pulsed** operation (**Delay ≠ 0**), the DO will return automatically from the active state to the inactive state after a duration equal to the delay without requiring a manual release operation.
- The following table describes the definitions for **DO Start A** and **Start B** operations with different Starter functions based on the schematic diagrams in **Section 2.19**.

Control Functions	DO Operations	
	Start A	Start B
Direct-On-Line	Start	-- (Not used)
Reduce-voltage	Reduce-voltage start	Full-voltage running
Forward-Reverse	Forward	Reverse
2-speed	Speed 1	Speed 2

Table 4-5 Definitions for DO Start A/Start B Operations under Various Control Functions

4.2.3 Non-fail-Safe Mode

During normal operation, the DO contact coil is operational. When the relay voltage is removed, the output contact is latched in a de-energized state, and the protected motor remains unprotected, referred to as **Non-fail-Safe** mode.

When the relay voltage returns, a previously operated DO configured for Trip/Alarm and Supplementary Outputs will be energized again within 1s. Meanwhile, the DO configured for other purposes (e.g., Start A, Motor Running) remains de-energized, regardless of its previous state before the voltage interruption.

4.3 Analog Output

The relay comes with one analog output from 4mA to 20mA. Connect the external analog input of DCS or Panel Meter to the relay output generating a DC signal proportional to the selected analog metering in the relay.

The following table describes the setting parameters for Analog Output.

Setting Parameter	Definitions	Range/Default*
AO_Zero	Defines the zero-scale value of the parameter when the analog output is 4mA.	-999,999 to 999,999 40*
AO_Full	Defines the full-scale value of the parameter when the analog output is 20mA.	-999,999 to 999,999 200*
AO_Key	Defines the parameter to which the analog output is proportional.	Ia*, Ib, Ic, P, IR, 3I0, Ullavg, Iavg, VARA1
AO hold time	Defines the period for which the AO maintains stable power and valid control signals after main power failure.	0-50 (x0.1s), 0*

0 means that the relay will stop the analog output signal immediately if power is lost
--

Table 4-6 Analog Output Setting Parameters

For example, an AO of 4-20mA is required to be proportional to Phase A Current (I_a). The maximum value of I_a is 2000A, and the minimum is 500A. As such, the AO_Key parameter should be programmed with I_a . The AO_Zero and AO_Full parameters should be programmed with the 500 and 2000, respectively. Therefore, when Phase A Current is 500A or below, the AO output is 4mA. When Phase A Current is 2000A, the AO output is 20mA. When Phase A Current is 1250A, the AO is $(1250A-500A) \times (20mA-4mA) / (2000A-500A) + 4mA = 12 (mA)$.

NOTE: Connection of DC voltage to the analog output terminals could result in damage to the relay!

4.4 Protection Overview

The relay realizes different protections based on the judgment for various operating conditions and the measurements in the operating process of the motor to ensure the safety running.

4.4.1 Motor States

The relay considers the motor is operating as soon as the current exceeding 7% of I_e (motor rated Current) is detected in the motor circuit for longer than 50ms. This criterion is referred to as $I_e < 0 (I_e \neq 0)$ in the following sections.

Two operation states are considered, **Start** and **Running** states.

4.4.1.1 Start State

The initial state of a motor is stop (See section 4.4.1.3 for stop criteria). The relay considers a motor starting from a stop state based on any of the following criteria:

- 1) A change (from open to close) in the interruption device (main contactor or circuit breaker) position is detected.
- 2) The maximum value of 3-phase current, I_{max} , satisfied either of the following conditions:
 - a) Exceeds starting current threshold (Default: $1.1I_e$) for longer than 20ms.
 - b) Meets $I_e < 0 (I_e \neq 0)$ criteria for an extended period of 100ms.

To help the user in the maintenance of the electrical process, the relay provides the **Last Start Current**, **Last Start Time**, **Start Count**, and other statistics (See Section 4.13.2), which can be retrieved via the HMI module or Communications.

4.4.1.2 Running State

The relay considers a motor transition to a running state based on the following criteria:

- 1) The interruption device (main contactor or circuit breaker) remains closed.
- 2) The maximum current, I_{max} ,
 - a) Falls below starting current return threshold (Default: $1.1I_e$) for condition a) in Starting detection criteria above with a minimum duration (Default: 2s)
 - b) Rises but still retains below $1.1I_e$ for at least 80ms for condition b) in Starting detection criteria above.

The following figures illustrate two cases of transition between starting and running processes.

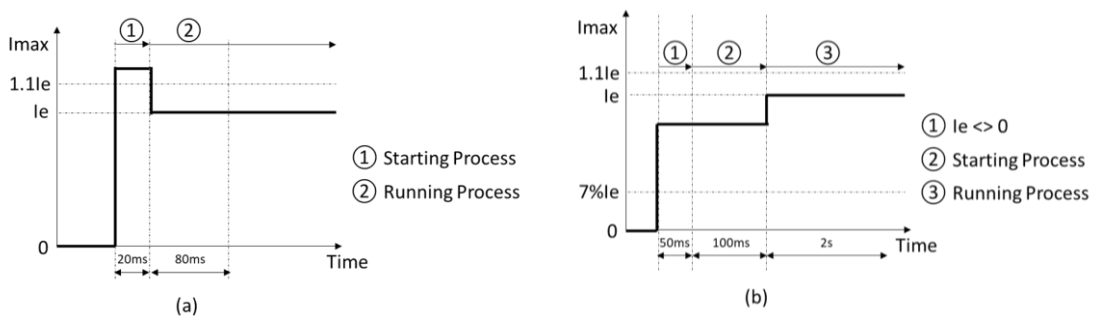

Figure 4-1 Transition between Starting and Running Processes

4.4.1.3 Stop State

The relay considers a motor as having no current flow across as soon as I_{max} falls below 6% of I_e in the motor circuit for longer than 50ms. This criterion is referred to as $I_e = 0$ in the following sections.

In either of the following circumstances, the motor is considered as completely stopped.

- 1) A change (from closed to open) in the interruption device position is detected.
- 2) Maximum current metering satisfied $I_e = 0$ threshold for an extended period of 80ms.

4.4.2 Protection and Motor State

4.4.2.1 Available Protection in Motor Start and Running State

As indicated in the following table, every protection element may work in a different state (start or running state).

Protection Function	Start State	Running State
Long Start protection	√	--
Thermal Overload protection	√	√
Jam protection	--	√
Ground Fault protection	√	√
MTA Failure	√	√
Phase Current Loss protection	√	√
Imbalance protection	√	√
Under Power protection	--	√
Short Circuit protection	√	√
Undervoltage protection	√	√
Overvoltage protection	√	√
Underload protection	--	√
tE Time protection	--	√
Overload protection	--	√
Interlock	√	√
LOP protection	√	√
Phase Reversal protection	√	√
Contactors protection	√	√
Emergency Stop alarm	√	√
Contactors Failure protection	√	√
ACB Trip Contactor	√	√
Residual Current protection	√	√
Negative Sequence protection	√	√
Closed-loop Abnormal protection	√	√
Contactors Abnormal protection	√	√
Block When Start protection	√	√
Thermo protection	√	√
TC (Overtemperature) protection	√	√
Insulation protection	√	√

"√" indicates that the protection function is **Available**, "--" indicates the protection function is **Not Available**.

Table 4-7 Processing of Protections in start state and running state

4.4.2.2 Block Protection When Motor Start

The following table describes the protections that can be inhibited to avoid nuisance alarms or trips with specified **Block Time** counted from motor starting.

Parameters	Range	Default
Block Time	0 to 99.99 s (0 means disabled)	10.00 s
Select	Thermal Overload, Jam, Ground Fault, Phase Current Loss, Imbalance, Under Power, Interlock, Short Circuit, Residual Current, Overload, Underload, tE time, Phase Reversal, Negative Sequence Current	N/A

Table 4-8 Block When Start Setting Parameters

4.4.3 Protection Reset Mode

The protection fault output can be programmed to be reset with either **Automatic** or **Manual**.

For the **Automatic** reset type, the protection trip/alarm is acknowledged without the intervention of a human operator if the fault is removed.

For the **Manual** reset type, the protection trip/alarm must be acknowledged by the user via the Reset button on the HMI module, **DI Reset Protection** control signal, or communications. Manual reset is used in applications and processes demanding safety checks before the starting process. In such an application, human intervention is the final check.

4.4.4 Mechanical Protection and Control

4.4.4.1 Start Control

4.4.4.1.1 Overview

➤ Start Inhibit

Repeat starting or intermittent motor operation will damage the motor and the whole network. Thus, any motor has a restriction on the number of starts that are allowed in a defined time window. When the protected motor is rated for a minimum time between starts or a specific maximum number of starts in a defined period, set the **Start Lock Time**, **Max. Start Count** and **Interval** accordingly.

If the motor is stopped or tripped within the **Start Lock Time**, the relay will prevent a new start until **Start Lock Time** is reached after the most recent start.

Suppose the relay detects that the **Max. Start Count** has been reached within the preset **Interval**, and the motor is already stopped or tripped, the relay will ignore any further start request until the time equal to the **Interval** has elapsed, counting from the oldest start.

➤ Anti-backspin Lockout

In some pump motor applications, fluid flowing backward through the pump may spin the motor after the motor is stopped. Any attempt to start the motor during this time can be damaging.

To prevent motor starts during the backspin period, the **Stop Lock Time** shall be set to define the waiting time after the motor was stopped or tripped that has to pass until a safety restart is possible.

4.4.4.1.2 Start Control Setting

The following table describes the range and default values of the setting parameters for Start Control.

Setting Parameter	Range	Default
Start Lock Time	0 to 9999 s (0 means disabled)	0
Stop Lock Time	0 to 9999 s (0 means disabled)	0
Max. Start Count	0 to 20 (0 means disabled)	0
Interval	1 to 9999 min	30

Table 4-9 Setting Parameters for Start Control

4.4.4.2 Start Block

Under any of the following circumstances, the relay will block the motor start request.

- 1) The motor is already in the start or running state
- 2) **Self-check** error (see **Section 4.14**)
- 3) Any protection alarm or trip occurs
- 4) **DI Start Block** signal received
- 5) **Start Control Block Time** block start period
- 6) **DI Stop** signal received

The **Start Block Reason** and **Remaining Lock Time** will be displayed on the HMI display module.

4.4.4.3 Long Start

4.4.4.3.1 Overview

If the motor fails to transmit from starting process to the running state (See **Section 4.4.1 Motor States**) within the specified time delay, the Long Start protection element will issue an alarm and/or trip the contactor depending on the configurations.

The logic diagram of Long Start Protection is illustrated in the following figure.

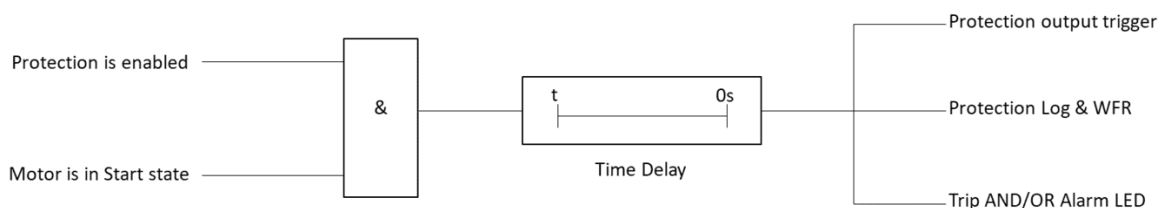

Figure 4-2 Logic Diagram of Long Start Protection

4.4.4.3.2 Long Start Setting

The following table describes the range and default values of the setting parameters for Long Start protection.

Setting Parameter	Range	Default		
Config	OFF, Trip, Alarm, Trip + Alarm	OFF		
Delay	0.10 to 99.99 s	30.00 s		
Supplementary Output	R1 <input type="checkbox"/>	R2 <input type="checkbox"/>	R3 <input type="checkbox"/>	N/A

Table 4-10 Long Start Protection Setting Parameters

4.4.4.4 Jam Protection

4.4.4.4.1 Overview

In the running stage, if the motor rotor is locked due to overload or mechanical malfunction, the motor is allowed to operate for a short period according to different overload capacities. However, if the related trouble can't be solved in time, the motor windings will be overheated quickly, and its insulation will break down, leading to the motor burning. The Jam protection is available only in the running state. The difference between the Jam and Short Circuit conditions is that the motor current rises dramatically based on a steady state in the former case.

When Jam protection is enabled, and the motor maximum current I_{max} exceeds the pickup threshold, I_{jam} , for longer than the time delay setting, the relay issues an alarm and/or trips the contactor depending on the protection output setting. The following figure illustrates the logic diagram for motor Jam protection.

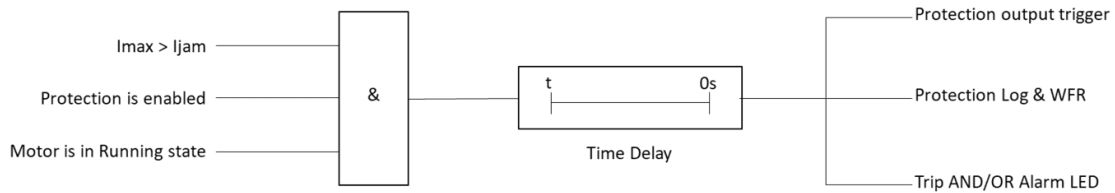

Figure 4-3 Logic Diagram of Jam Protection

4.4.4.4.2 Jam Settings

The following table describes the setting range and default value for the parameters of Jam Protection.

Setting Parameter	Range	Default		
Config	OFF, Trip, Alarm, Trip + Alarm	OFF		
Pickup	1.00 to 10.00 (xIe)	3.50		
Time Delay	0.10 to 99.99 s	4.00 s		
Supplementary Output	R1 <input type="checkbox"/>	R2 <input type="checkbox"/>	R3 <input type="checkbox"/>	N/A

Table 4-11 Jam Protection Setting Parameters

4.4.4.5 Thermal Overload Protection

The relay provides the locked rotor, running overload, and negative-sequence current imbalance protection using an inverse time thermal model. The thermal element accurately tracks the heating caused by load current and current imbalance as the motor accelerates and runs. In each case, the relay operates a thermal model with a trip value defined by the relay settings and a present heat estimate that varies with time and changing motor current. The motor's thermal estimate is expressed as **Heat Capacity** in the percentage of operation level. If the heat capacity reaches 100 percent, the protection element will issue an alarm and/or trip the contactor, depending on the protection output setting.

If the Thermal Overload protection is disabled, the relay reports the heat capacity as 0.

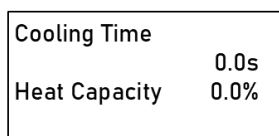

Figure 4-4 Heat Capacity Displayed on HMI module

4.4.4.5.1 Equivalent Current

The thermal model considers the heating effect of both the positive and negative current sequences. The positive and negative current sequences are combined to form an equivalent current, **leq**. The equivalent current for the operation of the Thermal Overload protection is calculated with the following equation:

$$I_{eq} = \sqrt{K1 \times I1^2 + K2 \times I2^2}$$

Where:

I1 = Positive sequence Current

I2 = Negative Sequence Current

K1 = Heating factor of positive sequence current

K2 = Heating factor of negative sequence current

There are:

K1 = 0.5, K2 = 6 for motor in 'cold' condition

K1 = 1, K2 = 6 for motor in 'hot' condition

A 'hot' condition means that the heat capacity of the motor is increasing, and the motor is approaching tripping. A 'cold' state means that the heat capacity is close to 0, i.e., the motor has cooled down and is ready to start.

4.4.4.5.2 Thermal Model

The thermal model is as follows:

$$t = \frac{35}{\left(\frac{I_{eq}}{I_{ov}}\right)^2 - 1.05^2} \times T_c$$

Where:

t = Trip time

Tc = Heating time constant preset by the user

Iov = Current setting for thermal protection

Ieq = Equivalent current as described above

Generally, the Iov shall be set as 1.0 to 1.2 multiple of Ie (usually 1.0Ie). And the user shall obtain the motor specification to set the Tc with a proper value.

The user also can quickly use the recommended Tc values based on the Trip class complied with IEC 60947-4-1.

Example

A motor datasheet declares the Safe Stall Time at 100% Volts with Hot state is 8 seconds, and its Rated Locked Rotor Amps is 7.2Ie.

From the following table, the Trip Class is known as 10, and the recommended Tc value is 6.5.

Trip Time Requirement as per IEC 60947-4-1					Recommended Tc (Iov = 1.0Ie)
Trip Class	Multiple of the current setting				
	1.05Ie	1.2Ie	1.5Ie	7.2Ie	
10A	> 2h	< 2h	≤ 2min	2s < T _{trip} ≤ 10s	3.5
10	> 2h	< 2h	≤ 4min	4s < T _{trip} ≤ 10s	6.5
20	> 2h	< 2h	≤ 8min	6s < T _{trip} ≤ 20s	10.0
30	> 2h	< 2h	≤ 12min	9s < T _{trip} ≤ 30s	16.0

**Trip Class – the maximum trip time in seconds under specified test conditions at 7.2 times the rated current according to IEC 60947-4-1.

Table 4-12 Recommended Tc with Trip Time Requirement by IEC 60974-4-1

The following table is a quick reference guide to the approximate tripping time (in seconds) calculated by the thermal model (providing I2 = 0, Iov = 1.0Ie, and motor in 'hot' condition).

t I/lov	Tc								
	0.1	0.5	1.0	3.0	5.0	7.0	10.0	16.0	20.0
1.5	3.050	15.251	30.501	91.503	152.505	213.508	305.011	488.017	610.022
2.0	1.208	6.040	12.079	36.238	60.397	84.556	120.794	193.270	241.588
3.0	0.443	2.216	4.432	13.295	22.159	31.022	44.318	70.909	88.636
4.0	0.235	1.175	2.349	7.048	11.747	16.446	23.494	37.590	46.988
5.0	0.146	0.732	1.465	4.394	7.323	10.252	14.646	23.433	29.292
6.0	0.100	0.501	1.003	3.009	5.015	7.021	10.029	16.047	20.059
7.2	0.069	0.345	0.690	2.069	3.449	4.829	6.898	11.037	13.797
8.0	0.056	0.278	0.556	1.669	2.782	3.895	5.565	8.903	11.129
9.0	0.044	0.219	0.438	1.314	2.190	3.066	4.381	7.009	8.761
10.0	0.035	0.177	0.354	1.062	1.770	2.477	3.539	5.662	7.078

Table 4-13 Quick Search for Tripping Time with Different Tc Settings and Overload Current

4.4.4.5.3 Thermal Alert

The relay additionally provides a thermal Alert with a threshold setting for early warning, which may allow the user to correct the problem before a thermal trip occurs.

The Alert threshold can be set as 0 to 99% (typically 90%) of the relay operation level. When the heat capacity of the motor exceeds the threshold, the Alarm LED on the relay will illuminate, indicating that the motor is approaching a thermal overload, and the alert time delay, after which the thermal protection will trip, will count down on the HMI module.

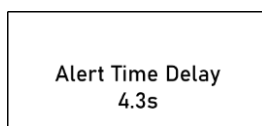

Figure 4-5 Alert Time Delay Displayed on HMI Module

4.4.4.5.4 Thermal Dissipation

After relay trips, the motor stops, and the heat capacity decreases until the thermal element has enough available heat capacity to allow the motor to start without tripping. This process is called ‘thermal dissipation’ or ‘cooling’. The relay supports two cooling modes, **Delay** and **Instant**.

In **Delay** mode, set the **Return Threshold** greater than the heat capacity required to start the motor without tripping.

In **Instant** mode, the protection returns instantaneously once the maximum current falls below 0.95 times I_{ov} (current settings for Thermal protection).

During the cooling process, the relay’s HMI displays the decreasing heat capacity with the countdown cooling time defined as the waiting time that has to pass until the relay allows reset. (Both heat capacity and cooling time are shown as 0 under **Instant** cooling mode).

The following figure illustrates the heat capacity and countdown cooling time at a moment of delayed cooling.

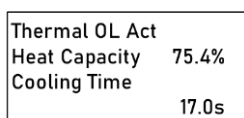

Figure 4-6 Heat Capacity and Cooling Time Displayed on the HMI

4.4.4.5.5 Reset Mode

The Reset Mode for Thermal Overload protection output shall be set independently based on the user’s application. There are two modes: **Automatic** and **Manual**. Please refer to **Section 4.4.3** for the descriptions.

4.4.4.5.6 Emergency Start

Where a motor forms part of an essential process, it is sometimes desirable to continue operation, even though the motor is subjected to a temperature above its design limits, and **Emergency Start** is justified for this application.

An emergency start can be initiated through the **DI Emergency Start** signal input or the HMI’s push buttons (set **Control Key** = Emergency). An emergency start signal will cause the Thermal Overload protection to reset, and the DO output contacts defined as Start A or Start B will operate sequentially.

Note that the relay will ignore the emergency start requests if other start inhibitions are not removed.

4.4.4.5.7 Thermal Overload Settings

The following table describes the setting range with the default value of the parameters for Thermal Overload protection.

Setting Parameter	Range	Default
Config	OFF, Trip, Alarm, Trip + Alarm	Trip + Alarm
Pickup (Iov)	1.00 to 10.00 (xIe)	1.00
Time Delay (Tc)	0.10 to 99.99	6.50
Cooling	Instant, Delay	Delay
Alert Trigger	0 to 99% (0 means thermal alert disabled)	0%
Return Threshold	0 to 100%	60%
Reset Mode	Auto, Manual	Manual
Supplementary Output	R1 <input type="checkbox"/> R2 <input type="checkbox"/> R3 <input type="checkbox"/>	N/A

Table 4-14 Thermal Overload Protection Setting Parameters

4.4.4.6 tE Time Protection

4.4.4.6.1 Overview

This protection applies to the motor of ignition protection type Increased-Safety ‘e’ (suppression of sparks and high temperatures) operating in hazardous locations.

As per IEC 60079-7: 2015:

Increased Safety “e” – Type of protection applied to electrical equipment or Ex Components in which additional measures are applied to increase security against the possibility of excessive temperatures and the occurrence of arcs and sparks.

*I*_A – Highest RMS value of current drawn by an AC motor when at rest or by an AC magnet with its armature clamped in the position of maximum air gap when supplied at rated voltage and a rated frequency.

*I*_A/*I*_N – Ratio between initial starting current *I*_A and rated current *I*_N.

tE – refers to the time in seconds in the following figure, taken for an AC rotor or stator winding, when carrying the initial starting current *I*_A, to be heated up to the limiting temperature from the temperature reached in rated service at the maximum ambient temperature.

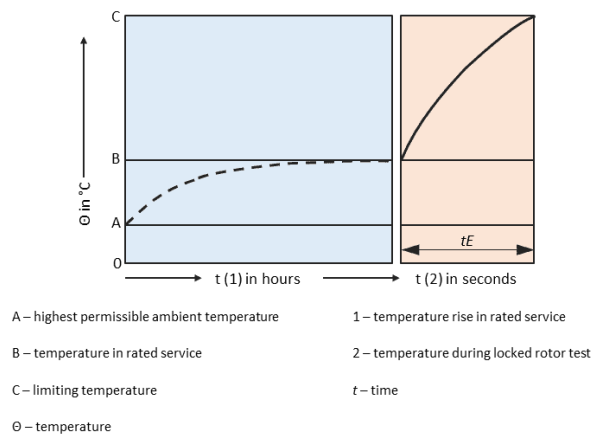

Figure 4-7 Diagram for the Determination of the Time

The *tE* protection consists of an overcurrent component with inverse time characteristics complied with the following formula:

$$\begin{aligned}
 \textcircled{1} \quad tE &= \frac{16 \times Tp}{(IA/IN) - 1} && \text{for } 1.2 < IA/IN < 2, \\
 \textcircled{2} \quad tE &= \frac{16 \times Tp}{(3 \times IA/IN) - 5} && \text{for } 2 \leq IA/IN \leq 7, \\
 \textcircled{3} \quad tE &= Tp && \text{for } IA/IN > 7
 \end{aligned}$$

Where *Tp* is the *tE* time when the starting current ratio (*I*_A/*I*_N) = 7 and is a user-programmable parameter with a setting range of 0.1 to 99.9 seconds. The current-time characteristic of the *tE* time delay as a function of *I*_A/*I*_N is shown in the following figure. The user shall select an appropriate curve to ensure the motor tripping within the permissible time indicated in the nameplate.

In no case

- a) shall the value of time tE be less than 5 s.
- b) shall the value of the starting current ratio I_A/I_N exceed 10.

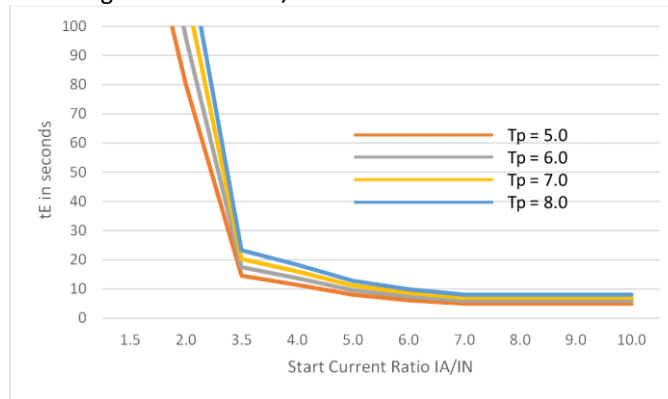

Figure 4-8 Current-Time Characteristic of the tE time as a Function of I_A/I_N

Example

As indicated on the motor nameplate below, $I_A/I_N = 6.1$ and $tE = 30s$. According to IEC 60079-7: 2015, the tripping time of the relay should be equal to the tE time $\pm 20\%$. The user shall use the formula ②, and the recommended T_p setting would be ~ 19.9 .



Figure 4-9 An Example of the Nameplate of Increased Safety Motor

4.4.4.6.2 tE Time Settings

The following table describes the setting range with the default value of the parameters for tE Time protection.

Setting Parameter	Range	Default
Config	OFF, Trip, Alarm, Trip + Alarm	OFF
Time Delay	0.10 to 99.99 s	6.00 s
Supplementary Output	R1 <input type="checkbox"/> R2 <input type="checkbox"/> R3 <input type="checkbox"/>	N/A

Table 4-15 tE Time Protection Setting Parameters

4.4.4.7 Under Power Protection

4.4.4.7.1 Overview

The relay provides Under Power protection to detect a load loss due to a shaft failure or dry running of the pump. This protection is available only when the motor is running and is disabled when it is starting.

The standard power protection element of the relay calculates the three-phase kW Total based on the following formula using the current and voltage measured.

$$P = U_{ab} \times I_a + U_{bc} \times I_c$$

Notes:

**The Under Power protection is not available if $I_e = 0$ (i.e., the motor is considered as having no current flowing across, see Section 4.4.1.3) or LOP detected since the current and voltage are not available.

**Be careful of the polarity and sequence of the current and voltage, otherwise the Under Power protection may be activated inadvertently.

When the Under Power protection is enabled and the kW Total calculated is less than the pickup threshold for longer than the time delay, the relay issues an alarm and/or trips the contactor depending on the output setting.

For Under Power protection, the tripping output could be reset automatically after the specified reset delay once the fault is acknowledged by human intervention.

The following figure illustrates the logic diagram for Under Power protection.

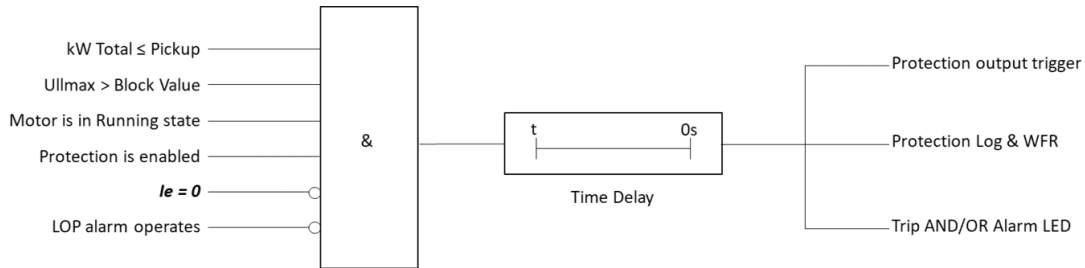

Figure 4-10 Logic Diagram of Under Power Protection

4.4.4.7.2 Under Power Settings

The following table describes the setting range and the default value for parameters of Under Power protection.

Setting Parameter	Range	Default
Config	OFF, Trip, Alarm, Trip + Alarm	OFF
Pickup	-999.9 to 999.9 (kW)	35.0
Time Delay	0.50 to 99.99 s	5.00 s
Block Value	0.30 to 0.95 (xUe)	0.60
Reset Delay	0 to 6000.0 s (0 means disabled)	0
Supplementary Output	R1 <input type="checkbox"/> R2 <input type="checkbox"/> R3 <input type="checkbox"/>	N/A

Table 4-16 Under Power Setting Parameters

4.4.4.8 Undervoltage Protection

4.4.4.8.1 Overview

Undervoltage conditions can occur in a power system as a result of the increased load or reduced supply voltage. A sustained Undervoltage condition will result in motor stalling with a decreased rotor speed. The relay provides the Undervoltage element to take appropriate action to safeguard the motor operation during abnormal or critical situations, for example, load shedding, source change-over, and emergency generator starting.

When the Undervoltage protection is enabled, and the phase-to-phase voltage Ullmax is less than the pickup threshold for longer than the time delay, the relay issues an alarm and/or trips the contactor depending on the output setting. This protection is available only when the motor is running and is disabled when it is starting.

Notes:

**The Undervoltage protection is not available if LOP is detected since the voltage is not available.

**Set No_I Lock to ON to block the Undervoltage element if Ie = 0 detected (i.e., the motor is considered as having no current flowing across, i.e., the motor is going to stop, see Section 4.4.1.3).

For Undervoltage protection, the tripping output could be reset automatically after the specified reset delay once the fault is acknowledged by human intervention.

The following figure illustrates the logic diagram for Undervoltage protection.

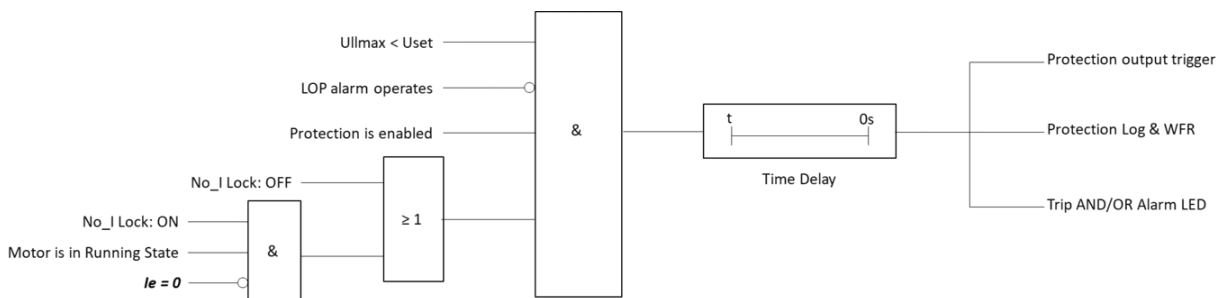

Figure 4-11 Logic Diagram of Undervoltage Protection

4.4.4.8.2 Undervoltage Setting

The following table describes the setting range and default values for the parameters of Undervoltage protection.

Setting Parameter	Range	Default
Config	OFF, Trip, Alarm, Trip + Alarm	OFF
Pickup	0.30 to 0.95 (xUe)	0.45
Time Delay	0.10 to 99.99 s	9.00 s
No_I Lock	ON, OFF	ON
Reset Delay	0 to 6000.0 s (0 means disabled)	0
Supplementary Output	R1 <input type="checkbox"/> R2 <input type="checkbox"/> R3 <input type="checkbox"/>	N/A

Table 4-17 Undervoltage Protection Setting Parameters

4.4.4.9 Overvoltage Protection

4.4.4.9.1 Overview

Overvoltage may lead to the destruction of the windings due to loss of insulation. The relay provides Overvoltage protection available only in the motor running state. When the Overvoltage protection is enabled, and the maximum phase-to-phase voltage U_{llmax} is greater than the pickup threshold for longer than the time delay, the relay issues an alarm and/or trips the contactor depending on the output setting.

The following figure illustrates the logic diagram for Overvoltage protection.

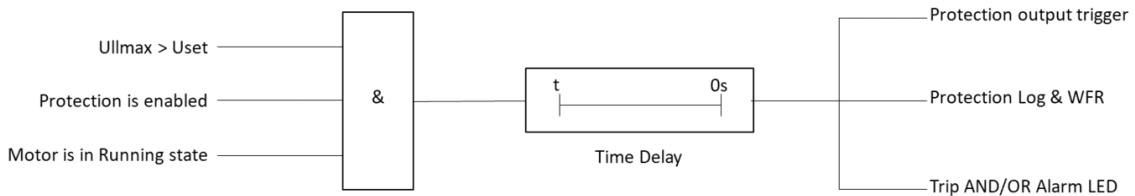

Figure 4-12 Logic Diagram of Overvoltage Protection

4.4.4.9.2 Overvoltage Settings

The following table describes the setting range and default values for the parameters of Overvoltage protection.

Setting Parameter	Range	Default
Config	OFF, Trip, Alarm, Trip + Alarm	OFF
Pickup	1.05 to 1.60 (xUe)	1.20
Time Delay	0.10 to 99.99 s	4.00 s
Supplementary Output	R1 <input type="checkbox"/> R2 <input type="checkbox"/> R3 <input type="checkbox"/>	N/A

Table 4-18 Setting Parameters for Overvoltage Protection

4.4.4.10 Overload Protection

4.4.4.10.1 Overview

The relay provides Overload protection consisting of a definite time overcurrent (DTOC) element as backup protection to be coordinated with other protections. This coordination is based on the fact that the fault current varies with the location of the fault due to the impedance differences between the fault and the source.

When the Overload Protection is enabled, and the maximum current is greater than the pickup threshold for longer than the time delay, the relay issues an alarm and/or trips the contactor depending on the output setting.

The following figure illustrates the logic diagram for Overload Protection.

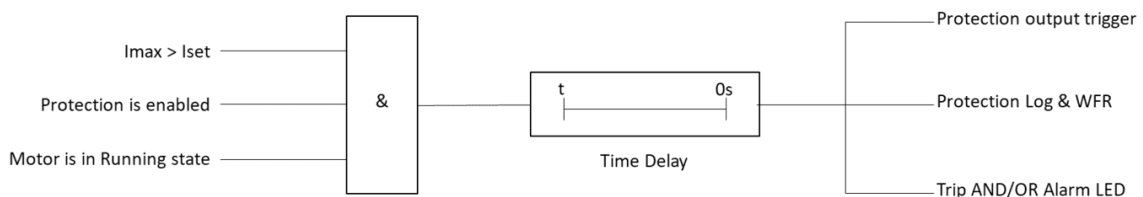

Figure 4-13 Logic Diagram of Overload Protection

4.4.4.10.2 Overload Setting

The following table describes the setting range with the default value for the parameters of Overload protection.

Setting Parameter	Range	Default
Config	OFF, Trip, Alarm, Trip + Alarm	OFF
Pickup	1.00 to 10.00 (xIe)	1.20
Time Delay	0.10 to 99.99 s	30.00 s
Supplementary Output	R1 <input type="checkbox"/> R2 <input type="checkbox"/> R3 <input type="checkbox"/>	N/A

Table 4-19 Setting Parameters for Overload Protection

4.4.4.11 Interlock Protection

4.4.4.11.1 Overview

This protection is used to monitor the external control signal. If the Interlock protection is enabled and the **DI Interlock** is active, and the signal persists for longer than the time delay, the relay issues an alarm and/or trips the contactor depending on the output setting (several DIs can be set to **Interlock** simultaneously but as long as one of them is active, the relay will take action to respond to it).

Note

During the power loss Ride-Through period, the Interlock Protection will be blocked (see **Section 4.17**).

The following figure illustrates the logic diagram for Interlock protection.

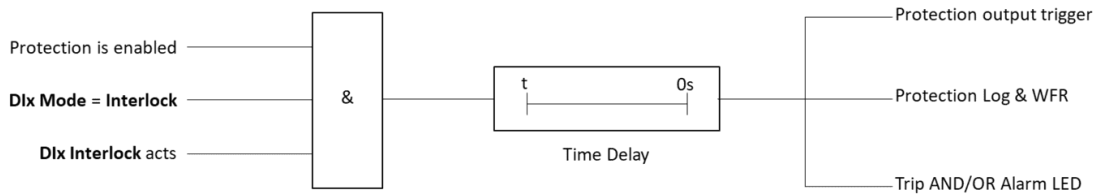

Table 4-20 Interlock Protection Logic Diagram

4.4.4.11.2 Interlock Protection Setting

The following table describes the setting parameters for Interlock protection.

Setting Parameter	Range	Default
Config	OFF, Trip, Alarm, Trip + Alarm	OFF
Time Delay	0 to 99.99 s	0.20 s
Supplementary Output	R1 <input type="checkbox"/> R2 <input type="checkbox"/> R3 <input type="checkbox"/>	N/A

Table 4-21 Interlock Protection Setting Parameters

4.4.4.12 Underload Protection

4.4.4.12.1 Overview

For a canned motor or magnetic pump, dry running condition, which happens when pumped fluid flashes, can lead to accelerated wear or shattering by thermal shock. The relay provides an Underload element which is only available when the motor is running and $I_e < 0$ ($I_e \neq 0$) is detected (i.e., the motor is considered to be operational and has a low current flowing across, see **section 4.4.1**). When the Underload protection is enabled, and the average current I_{avg} is lower than the pickup threshold for longer than the time delay, the relay issues an alarm and/or trips the contactor depending on the output setting.

After the relay trips, the connected DCS (distributed control system) will adjust related configurations to restore good operating conditions. The tripping output could be reset automatically after the specified reset delay once the fault is acknowledged by human intervention.

The following figure illustrates the logic diagram for Underload protection.

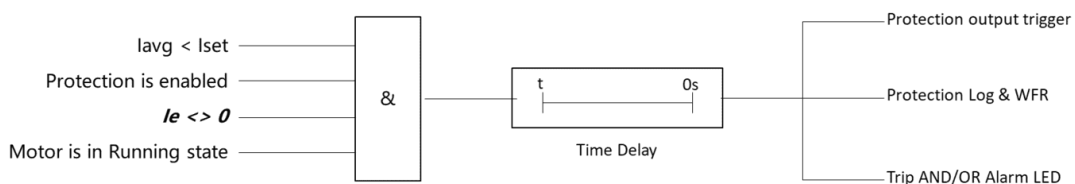

Figure 4-14 Logic Diagram of Underload Protection

4.4.4.12.2 Underload Setting

The following table describes the setting range and default values for the parameters of Underload protection.

Setting Parameter	Range	Default
Config	OFF, Trip, Alarm, Trip + Alarm	OFF
Pickup	0.10 to 1.00 (xIe)	0.40
Time Delay	0 to 9999 s	20 s
Reset Delay	0.0 to 6000.0 s (0 means disabled)	0
Supplementary Output	R1 <input type="checkbox"/> R2 <input type="checkbox"/> R3 <input type="checkbox"/>	N/A

Table 4-22 Underload protection

4.4.4.13 Closed-loop Failure Protection

4.4.4.13.1 Overview

The relay provides flexible closed-loop failure logic during the motor start and running stage.

However, if the **DO Start A** or **Start B** output is active during the motor start process, the relay fails to receive the **DI KMA/KMB State** closed status feedback, or if the PMC-MTA is connected and the **Ie = 0** is detected (i.e., the motor is considered as not operational, see **Section 4.4.1.1**). The relay judges that the motor can't be started due to a closed-loop failure.

Another condition is that during the motor running stage, the **DI KMA/KMB State** returns a closed state, and **Ie = 0** is detected, although the PMC-MTA is connected. In another word, the motor circuit is open due to closed-loop failure.

If any of the above fault conditions persist for longer than the time delay, the relay will issue an alarm and/or trip the contactor, depending on the output setting.

Note

During the power loss Ride-Through period, the Closed-loop Failure Protection will be blocked (see **Section 4.17**).

The following figure illustrates the logic diagram for Closed-loop Failure protection.

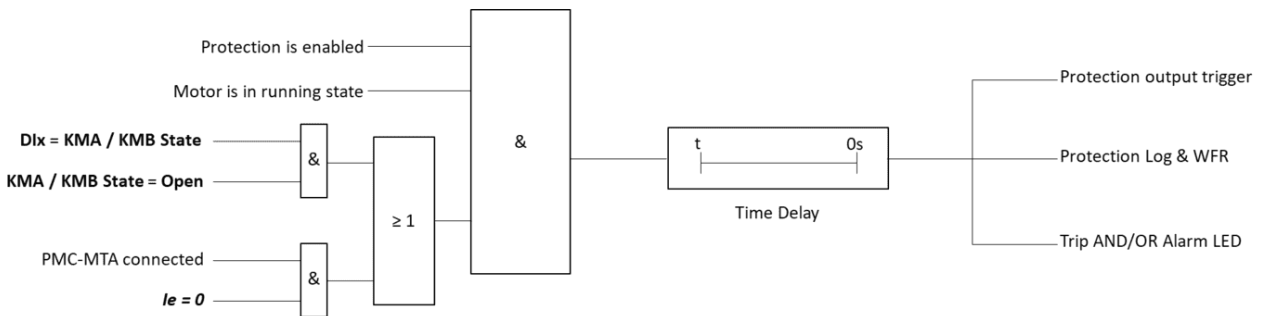

Figure 3-17 Logic Diagram of Closed-loop Failure Protection

4.4.4.13.2 Closed-loop Failure Setting

The following table describes the setting parameters for Closed-loop Failure protection.

Setting Parameter	Range	Default
Config	OFF, Trip, Alarm, Trip + Alarm	OFF
Time Delay	0.1 to 99.99 s	1.0 s
Supplementary Output	R1 <input type="checkbox"/> R2 <input type="checkbox"/> R3 <input type="checkbox"/>	N/A

Table 4-23 Closed-loop Failure Protection Setting Parameters

4.4.4.14 Contactor Protection

4.4.4.14.1 Overview

Generally, the Breaking Capacity of the contactor is $6 \cdot I_e$ to $8 \cdot I_e$. When the Contactor protection is enabled, and the circuit fault current exceeds the interrupting ratings of the main contactor, the Contactor protection element will energize the shunt trip coil of the circuit breaker to clear the fault and prevent the contactor from opening to avoid arcing or melting.

The following figure illustrates the logic diagram for Contactor protection.

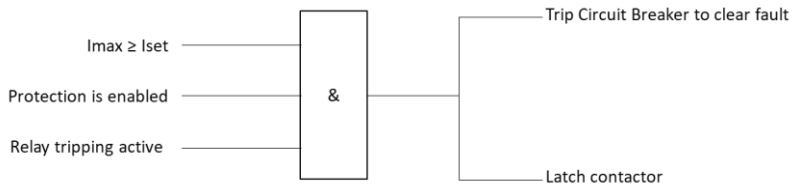

Figure 3-18 Logic Diagram of Contactor Protection

4.4.4.14.2 Contactor Protection Setting

The following table describes the setting range and default values for the parameters of Contactor Protection.

Setting Parameter	Range	Default
Config	ON, OFF	OFF
Pickup (contactor breaking capacity)	4.0 to 20.0 (xle)	8.0
Supplementary Output	R1 <input type="checkbox"/> R2 <input type="checkbox"/> R3 <input type="checkbox"/>	N/A

Table 4-24 Contactor Protection Setting Parameters

4.4.4.15 Contactor Failure Protection

4.4.4.15.1 Overview

A welded/sticking contactor will fail to disconnect the motor when there is a fault or a stop command has been received. The relay detects this failure and trips the circuit breaker to break the motor circuit to ensure the equipment's safety.

After the DO trip output has been activated, if the maximum current remains above the pickup threshold, or the **DI KMA/KMB State** shows a closed state for longer than the time delay, the protection will trip the circuit breaker.

Set **Stop Trigger** to **OFF** if the Contactor Failure protection is unexpected when the DO trip output is also used to stop the motor.

Note

During the power loss Ride-Through period, the Contactor Failure protection will be blocked (see Section 4.17).

The following figure illustrates the logic diagram for Contactor Failure protection.

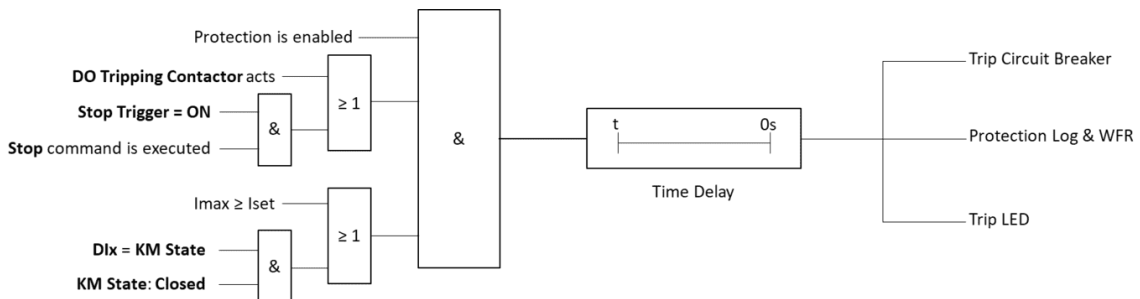

Figure 4-15 Logic Diagram for Contactor Failure Protection

4.4.4.15.2 Contactor Failure Setting

The following table describes the setting parameters for Contactor Failure protection.

Setting Parameter	Range	Default
Config	ON, OFF	OFF
Pickup	0.10 to 5.00 (xle)	0.30
Time Delay	0.10 to 99.99 s	0.50
Stop Trigger	ON, OFF	ON
Supplementary Output	R1 <input type="checkbox"/> R2 <input type="checkbox"/> R3 <input type="checkbox"/>	N/A

Table 4-25 Setting Parameters for Contactor Failure Protection

4.4.4.16 ACB (Air Circuit Breaker) Trip Contactor

4.4.4.16.1 Overview

Usually, the Distributed Control System (DCS) retrieves motor running feedback through the auxiliary contacts of the contactor. When a circuit breaker is working as the tripping output, the DCS will fail to follow up the circuit breaker operation, which may bring trouble to the process. Therefore, the relay provides the ACB Trip Contactor element to operate the contactor after the time delay.

Note

During the power loss Ride-Through period, the ACB Trip Contactor protection will be blocked (see **Section 4.17**).

The following figure illustrates the logic diagram for ACB Trip Contactor application.

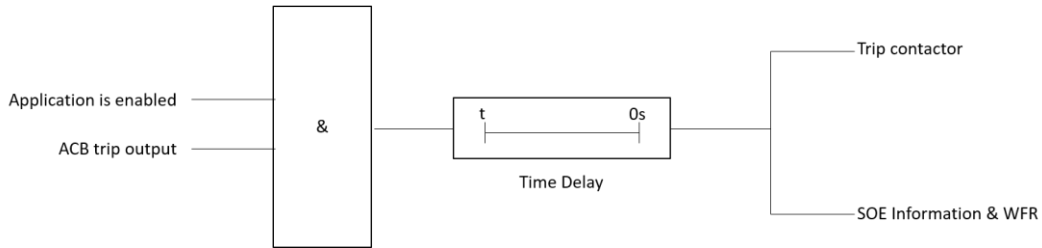

Figure 4-16 ACB Trip Contactor Application Logic Diagram

4.4.4.16.2 ACB Trip Contactor Setting

The following table illustrates the setting range and default values for the parameters of the ACB Trip Contactor.

Setting Parameter	Range	Default
Config	ON, OFF	OFF
Time Delay	0.10 to 99.99 s	1.00
Supplementary Output	R1 <input type="checkbox"/> R2 <input type="checkbox"/> R3 <input type="checkbox"/>	N/A

Table 4-26 ACB Trip Contactor Application Setting Parameters

4.4.4.17 Emergency Stop Alarm

4.4.4.17.1 Overview

This protection is used to signal an alarm for an emergency stop to remind the user. When the Emergency Stop Alarm is enabled, and the **DI Emergency Stop** contacts operate, the relay issues an alarm (several DIs can be set to **Emergency Stop** simultaneously, but as long as one acts, the relay will take actions to respond to it).

The following figure illustrates the logic diagram for Emergency Stop Alarm feature.

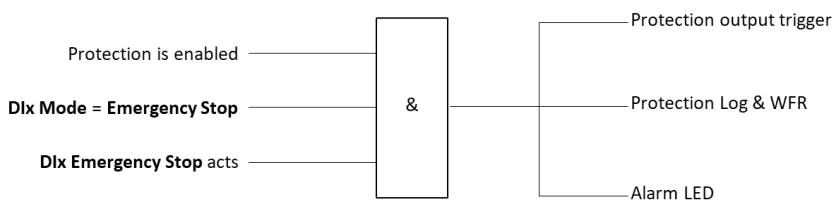

Figure 4-17 Logic Diagram of Emergency Stop Alarm

4.4.4.17.2 Emergency Stop Alarm Setting

The following table illustrates the setting range and default values for the parameters of Emergency Stop Alarm feature.

Setting Parameter	Range	Default
Config	ON, OFF	OFF
Supplementary Output	R1 <input type="checkbox"/> R2 <input type="checkbox"/> R3 <input type="checkbox"/>	N/A

Table 4-27 Emergency Stop Alarm Setting

4.4.4.18 Thermo Protection

4.4.4.18.1 Overview

This protection monitors the winding temperature of a motor equipped with PTC/NTC resistor sensors. When the winding's temperature exceeds the motor's permissible temperature, the sensor undergoes a rapid change in resistance relative to the change in temperature (For the PTC sensor, the resistance increases as the temperature rises, and for the NTC sensor, the resistance decreases as the temperature rises).

When the PTC resistance input exceeds the upper limit or the NTC resistance input falls below the lower limit for longer than the specified delay, the relay issues an alarm or trips the contactor, depending on the protection output setting.

As the motor cools, the winding's temperature restores to an acceptable level. When the PTC resistance input decreases below the lower limit, or the NTC resistance input increases above the upper limit, this protection can be reset.

Note

The thermo protection will be blocked when short-circuit ($R < 20\Omega$) or open-circuit ($R > 32k\Omega$) is detected. The user can enable Short Circuit Alarm or Open Circuit Alarm to get a notification in these conditions.

The following figure illustrates the logic diagram for Thermo protection.

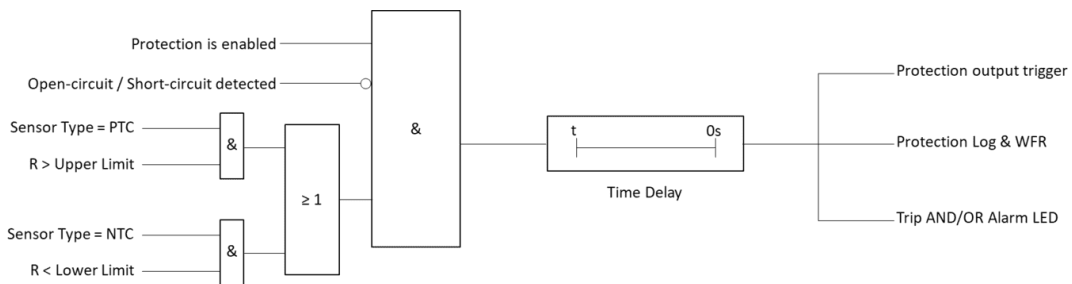

Figure 4-18 Logic Diagram of Thermo Protection

4.4.4.18.2 Thermo Protection Setting

The following table illustrates the setting range and default values for the parameters of Thermo protection.

Setting Parameter	Range	Default
Config	OFF, Trip, Alarm, Trip + Alarm	OFF
Type	PTC, NTC, Mix	PTC
Upper Limit	0.10 to 30.00 (kΩ)	10.00
Lower Limit	0.10 to 30.00 (kΩ)	8.00
Time Delay	0.1 to 99.99 s	2.00 s
Short cct. ALM	OFF, ON	OFF
Open cct. ALM	OFF, ON	OFF
Supplementary Output	R1 <input type="checkbox"/> R2 <input type="checkbox"/> R3 <input type="checkbox"/>	N/A

Table 4-28 Thermo Protection Setting Parameters

4.4.4.19 Insulation Protection

4.4.4.19.1 Overview

This relay can measure the insulation resistance against the ground with the optional PMC-KR module.

When the measured insulation resistance falls below the pickup threshold for longer than 40ms, the relay issues an alarm or trips the contactor, depending on the protection output setting. If the Protection Reset Mode is set to Auto, the tripping output could be reset automatically after 1s once the fault is cleared.

The following figure illustrates the logic diagram for Insulation protection.

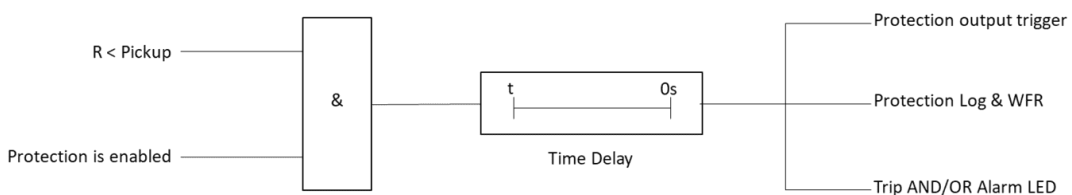

Figure 4-19 Logical Diagram for Insulation Protection

4.4.4.19.2 Insulation Protection

The following table illustrates the setting range and default values for the parameters of Insulation protection.

Setting Parameter	Range	Default
Config	OFF, Trip, Alarm, Trip + Alarm	OFF
Pickup	0.1 to 50.0 (MΩ)	1.0
Supplementary Output	R1 <input type="checkbox"/> R2 <input type="checkbox"/> R3 <input type="checkbox"/>	N/A

Table 4-29 Insulation Protection Setting Parameters

4.4.5 Electrical Fault Protection and Control

4.4.5.1 Ground Fault Protection

4.4.5.1.1 Overview

A Ground Fault (also called Earth Fault) is an inadvertent connection between the energized conduct and ground, usually occurring when the insulation is broken down due to moisture or vibration.

The Ground Fault protection is carried out based on a relay’s internal Zero Sequence Current calculation from the sum of the phase currents. When Ground Fault protection is enabled, and the calculated neutral current (3I0) exceeds the pickup threshold, Iset for longer than the time delay, the relay issues an alarm and/or trips the contactor depending on the protection output setting.

Considering the current characteristics, the relay provides two independent time delay settings, **Start Delay** and **Run Delay**, for Ground Fault protection in starting and running processes, respectively. Set a longer start delay to allow the Ground Fault element to ride through the false residual current caused by CT saturation during motor start.

The relay can provide the following diagnostic indicating where the Ground Fault occurs in the protection log.

- A/B/C Ground Fault
- AB/BC/CA Ground Fault
- ABC Ground Fault

The following figures illustrate the logic diagrams for Ground Fault protection.

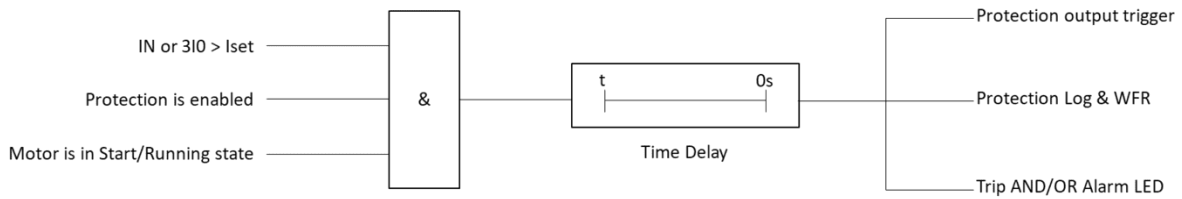

Figure 4-20 Logic Diagram of Ground Fault Protection in Start State

4.4.5.1.2 Ground Fault Settings

The following table describes the setting range and default values for the parameters of Ground Fault protection.

Setting Parameter	Range	Default
Config	OFF, Trip, Alarm, Trip + Alarm	Trip + Alarm
Pickup	0.10 to 10.00 (xIe)	1.00
Start Delay	0 to 99.99 s	0.50 s
Run Delay	0 to 99.99 s	0.10 s
Supplementary Output	R1 <input type="checkbox"/> R2 <input type="checkbox"/> R3 <input type="checkbox"/>	N/A

Table 4-30 Ground Fault Setting Parameters

4.4.5.2 MTA Failure Alarm

4.4.5.2.1 Overview

The external MTA current transducer is used for measuring the motor phase current. When the MTA Failure Alarm is enabled, and the secondary of the current transducer is disconnected for longer than the time delay, the relay will issue an alarm, and the event will be recorded in the protection log.

4.4.5.2.2 MTA Failure Impact on Other Protection Elements

Phase Current Loss and **Imbalance** elements require accurate current for correct operation. It is critical that the relay detects the MTA Failure condition and prevents the operation of these elements. For example, if a plug-in connector is loose on the PMC-MTA’s output, the relay MTA Failure logic accurately determines that this loss of input current is an MTA Failure condition and does not trip. If the current-determined relay elements are used for tripping decisions, please block these elements when the current component is no longer valid (see **Block MTA Failure** in **Section 4.4.5.3** and **4.4.5.4**).

4.4.5.2.3 MTA Failure Alarm Settings

The following table describes the setting range and default values for the parameters of the MTA Failure Alarm.

Setting Parameter	Range	Default
Config	OFF, ON	OFF
Time Delay	0.10 to 99.99 s	0.50 s
Supplementary Output	R1 <input type="checkbox"/> R2 <input type="checkbox"/> R3 <input type="checkbox"/>	N/A

Table 4-31 MTA Failure Alarm Setting Parameters

4.4.5.3 Phase Current Loss Protection

4.4.5.3.1 Overview

The relay provides Phase Current Loss protection based on the current detection. In phase current loss conditions, the motor draws excessive current from the remaining phases, quickly overheating the motor windings.

When the Phase Current Loss protection is enabled and the minimum current, I_{min} , is less than the expected motor no-load current ($0.125 \cdot I_e$), but the maximum current I_{max} is greater than the expected motor light-load current ($0.25 \cdot I_e$) for longer than the time delay, the relay issues an alarm and/or trips the contactor depending on the output setting.

The relay provides further diagnostic indicating where the Phase Current Loss occurs in the protection log.

- Loss of IA
- Loss of IB
- Loss of IC

The following figure illustrates the logic diagram for Phase Current Loss protection.

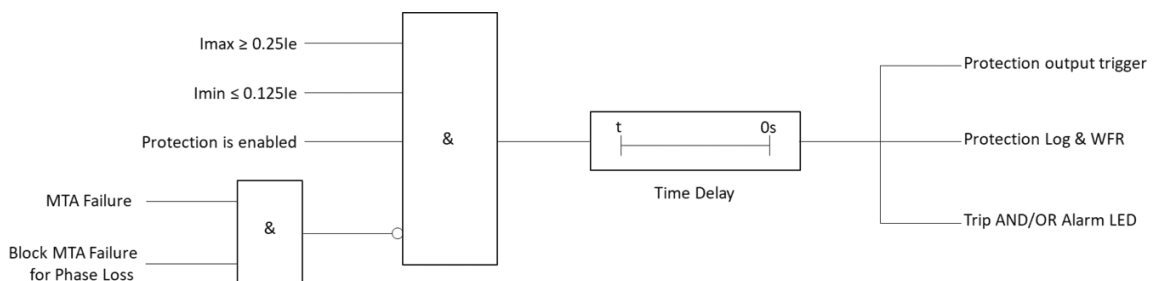

Figure 4-21 Logic Diagram of Phase Current Loss Protection

4.4.5.3.2 Phase Current Loss Settings

The following table describes the setting parameters and the default values for Phase Current Loss protection.

Setting Parameter	Range	Default
Config	OFF, Trip, Alarm, Trip + Alarm	Trip + Alarm
Time Delay	0.10 to 99.99 s	2.50 s
Block MTA Failure	Yes, No	Yes
Supplementary Output	R1 <input type="checkbox"/> R2 <input type="checkbox"/> R3 <input type="checkbox"/>	N/A

Table 4-32 Phase Current Loss Protection Setting Parameters

4.4.5.4 Imbalance Protection

4.4.5.4.1 Overview

Motor stator current imbalance caused by unbalanced terminal voltage will generate an excessive negative sequence component leading to significant rotor heating. The relay provides additional Imbalance protection with current imbalance calculation.

When the Imbalance protection is enabled, and the calculated current imbalance% exceeds the pickup threshold for longer than the time delay, the relay issues an alarm and/or trips the contactor depending on the output setting. This protection will be disabled if the motor current magnitude doesn't satisfy $I_e \lt 0$ ($I_e \neq 0$) (i.e., the motor is considered not operating, see **Section 4.4.1**).

The imbalance current is calculated in this way:

$$I_{\text{imbal.}} = \frac{\text{Max} [(I_{\text{max}} - I_{\text{av}}), (I_{\text{av}} - I_{\text{min}})]}{\text{Max} (I_{\text{av}}, I_e)} \times 100\%$$

Where

$I_{\text{imbal.}}$ = Current imbalance percentage

I_{max} = Max. current of 3 phases

I_{min} = Min. current of 3 phases

I_{av} = Average current of 3 phases

I_e = Motor rated current

The following figure illustrates the logic diagram for Imbalance protection.

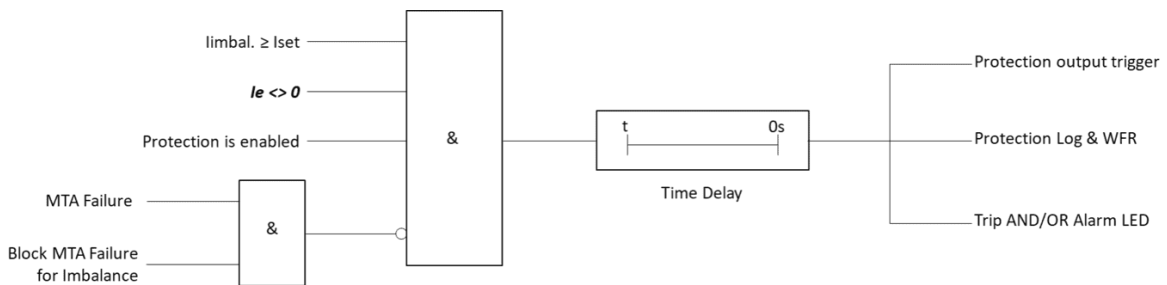

Figure 4-22 Logic Diagram of Imbalance Protection

4.4.5.4.2 Imbalance Settings

The following table describes the setting parameters for Imbalance protection.

Setting Parameter	Range	Default
Config	OFF, Trip, Alarm, Trip + Alarm	Alarm
Pickup	10 to 100 (%)	30
Time Delay	0.10 to 99.99 s	5.00 s
Block MTA Failure	Yes, No	Yes
Supplementary Output	R1 <input type="checkbox"/> R2 <input type="checkbox"/> R3	N/A

Table 4-33 Imbalance Protection Setting Parameters

4.4.5.5 Short Circuit Protection

4.4.5.5.1 Overview

A short circuit is indicated by an abrupt increasing current caused by the direct connection between the two points with different electrical potentials.

When the Short Circuit protection is enabled, and the maximum current is greater than the pickup threshold for longer than the time delay, the relay issues an alarm and/or trips the contactor depending on the output setting.

Use **Start Multiple** to set the sensitivity of the short circuit element from 1.00*pickup to 2.00*pickup in the motor start process.

The relay provides the following diagnostics indicating where the Short Circuit fault occurs in the protection log (the ground fault usually is regarded as a typical condition of short circuit fault):

- A/B/C ground fault
- AB/BC/CA ground fault
- ABC ground fault
- AB/BC/CA phase-to-phase short circuit
- ABC short circuit

The following figure illustrates the logic diagram for Short Circuit protection.

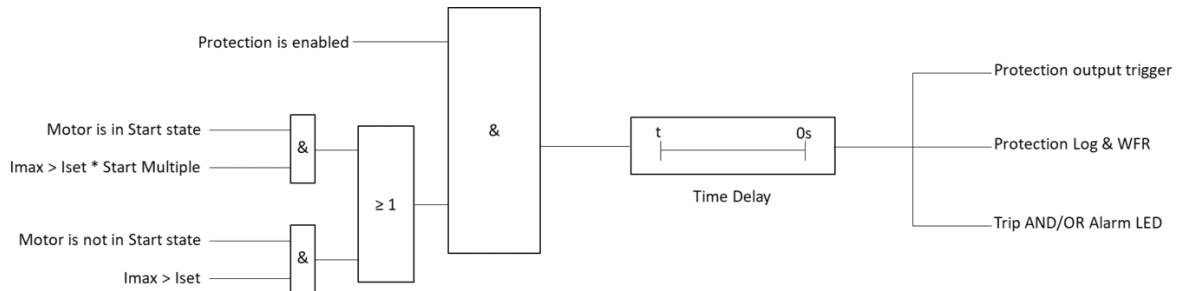

Figure 4-23 Logic Diagram of Short Circuit Protection

4.4.5.5.2 Short Circuit Setting

The following table describes the setting range and default values for the parameters of Short Circuit protection.

Setting Parameter	Range	Default
Config	OFF, Trip, Alarm, Trip + Alarm	Trip + Alarm
Pickup	1.00 to 10.00 (xIe)	7.50
Start Multiple	1.00 to 2.00	1.00
Time Delay	0 to 99.99 s	0
Supplementary Output	R1 <input type="checkbox"/> R2 <input type="checkbox"/> R3 <input type="checkbox"/>	N/A

Table 4-34 Short Circuit Protection Setting Parameters

4.4.5.6 Loss of Phase Voltage (LOP) Alarm

4.4.5.6.1 Overview

The relay provides the Loss of phase voltage (LOP) alarm upon detecting a loss of relay AC voltage input, such as that caused by blown potential fuses or by the operation of a molded-case circuit breaker (MCCB).

When the LOP alarm is enabled, and the maximum line voltage drops below $0.2 \cdot U_e$, but $I_e < 0$ ($I_e \neq 0$) is detected, see Section 4.4.1, or the magnitude difference between any line voltage is larger than $0.2 \cdot U_e$ for longer than 2 seconds, the LOP alarm output operates and the event will be recorded to the protection log and waveform recorder, with the Alarm LED turning on. Once the minimum voltage restores to $0.9 \cdot U_e$, the LOP alarm returns.

The relay provides the following diagnostics indicating where the LOP fault occurs in the protection log:

- Loss of UA/UB/UC
- Loss of UAB/UBC/UCA
- ABC Phase Loss

The following figure illustrates the logic diagram for LOP Alarm.

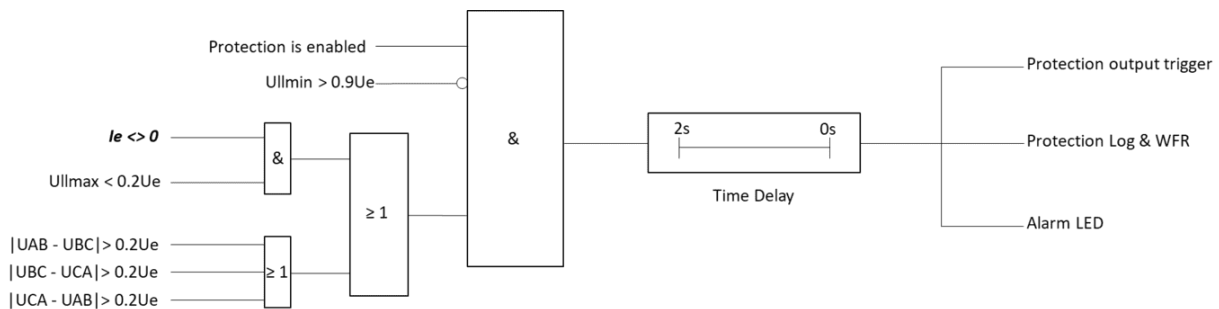

Figure 4-24 Logic Diagram for LOP Alarm

4.4.5.6.2 LOP Alarm Setting

The following table describes the setting range and default values for the parameters of the LOP Alarm.

Setting Parameter	Range	Default
Config	OFF, ON	ON
Supplementary Output	R1 <input type="checkbox"/> R2 <input type="checkbox"/> R3 <input type="checkbox"/>	N/A

Table 4-35 LOP Alarm Setting Parameters

4.4.5.7 Phase Reversal Protection

4.4.5.7.1 Overview

The phase reversal affects all the voltage and current measurements in the same way, disregarding which two phases are being swapped.

The relay uses phase currents and/or phase voltages to determine that the phase rotation sequence applied to the relay matches the **Current Sequence** and/or **Voltage Sequence** settings. When the Phase Reversal protection is enabled, and the incorrect phase sequence is applied for longer than 200ms, the relay issues an alarm and/or trips the contactor depending on the output setting.

The relay provides the following diagnostics indicating where the Phase Reversal occurs in the protection log:

- Voltage (U) phase sequence error
- Current (I) phase sequence error
- Voltage and Current phase sequence error

The following figure illustrates the logic diagram for Phase Reversal protection.

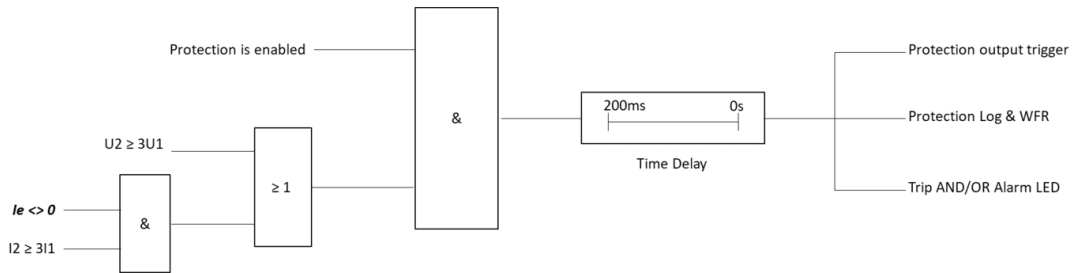

Figure 4-25 Phase Reversal Protection Logic Diagram

Where

U_2 – Voltage negative sequence component, U_1 – Voltage positive sequence component.

I_2 – Current negative sequence component, I_1 – Current positive sequence component.

4.4.5.7.2 Phase Reversal Setting

The following table describes the setting range and default values for the parameters of Phase Reversal protection.

Setting Parameter	Range	Default
Config	OFF, Trip, Alarm, Trip + Alarm	OFF
Supplementary Output	R1 <input type="checkbox"/> R2 <input type="checkbox"/> R3 <input type="checkbox"/>	N/A

Table 4-36 Phase Reversal Parameter Settings

4.4.5.8 Residual Current Protection

4.4.5.8.1 Overview

Residual current protection requires an external transducer, PMC-MIR, measuring the three-phase and neutral wires connected to the motor.

The relay provides two-level protection for residual current with independent threshold and time delay settings (see **Table 4-37**).

Use **Start Multiple** to set the sensitivity of the residual current element from 1.00*pickup to 2.00*pickup in the motor start process.

The following figure illustrates the logic diagram for Residual Current protection.

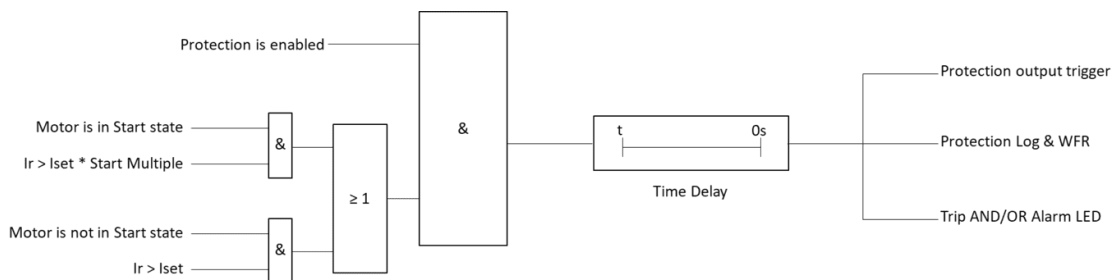

Figure 4-26 Residual Current Protection Logic Diagram

4.4.5.8.2 Residual Current Setting

The following table describes the setting range and default values for the parameters of Residual Current protection.

Setting Parameter	Range	Default
Level I		
Config	OFF, Trip, Alarm, Trip + Alarm	OFF
Pickup	20.0 to 5000.0 (mA)	300.0
Delay	0 to 99.99 (s)	5.00
Multiple	1.00 to 2.00	1.00
Supplementary Output	R1 <input type="checkbox"/> R2 <input type="checkbox"/> R3 <input type="checkbox"/>	N/A
Level II		
Config	OFF, Trip, Alarm, Trip + Alarm	OFF
Pickup	20.0 to 5000.0 (mA)	500.0
Delay	0 to 99.99 (s)	2.00
Multiple	1.00 to 2.00	1.00
Supplementary Output	R1 <input type="checkbox"/> R2 <input type="checkbox"/> R3 <input type="checkbox"/>	N/A

Table 4-37 Residual Current Protection Setting Parameters

4.4.5.9 Negative Sequence Overcurrent Protection

4.4.5.9.1 Overview

The relay offers a Negative Sequence Overcurrent protection to be used in addition to or instead of the current imbalance protection to detect phase-to-phase faults, phase reversal, single phasing, and heavy motor imbalance.

When this protection is enabled, and the negative sequence current, I_2 is greater than the pickup threshold for longer than the time delay, the relay issues an alarm and/or trips the contactor depending on the output setting.

False negative sequence current can transiently appear when a circuit breaker or contactor is closed. To avoid tripping for this transient condition, set a longer **Start Delay** for the negative sequence overcurrent protection element during the motor start.

The following figure illustrates the logic diagram for negative sequence overcurrent protection.

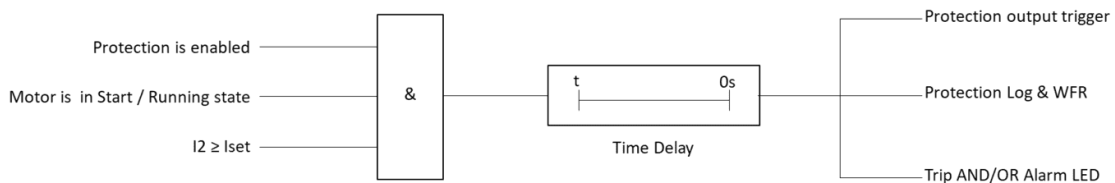

Figure 4-27 Negative Sequence Overcurrent Protection Logic Diagram

4.4.5.9.2 Negative Sequence Overcurrent Setting

The following table describes the setting range and default values for the parameters of Negative Sequence protection.

Setting Parameter	Range	Default
Config	OFF, Alarm, Trip, Alarm + Trip,	OFF
Pickup	0.10 to 10.00 (xIe)	1.20
Start Delay	0.00 to 99.99 s	4.00
Run Delay	0.00 to 99.99 s	2.00
Supplementary Output	R1 <input type="checkbox"/> R2 <input type="checkbox"/> R3 <input type="checkbox"/>	N/A

Table 4-38 Negative Sequence Overcurrent Protection Setting Parameters

4.4.5.10 ontactor Abnormal Protection

4.4.5.10.1 Overview

Under different running conditions and starter control (see **Section 2.19**), the relay detects the contactor's abnormal condition via the **DI KMA / KMB State** connected to the auxiliary contacts.

Based on the schematic wiring diagram and DI/DO configurations in **Section 2.19**, when the Contactor Abnormal protection is enabled, and the following abnormal condition is detected for longer than the time delay, the relay issues an alarm and/or trips the contactor depending on the output setting.

Motor Condition	Abnormal Contactor Condition
Direct-On-Line start or running	DI KMA State = Open
Reduce-voltage start (Full-voltage start)	DI KMA State = Open (DI KMB State = Open)
Forward-Reverse or Two-Speed running	DI KMA State = Closed and DI KMB State = Closed simultaneously
Forward or Speed 1 running	DI KMB State = Closed
Reverse or Speed 2 running	DI KMA State = Closed
VFD start (Cooler start)	DI KMA State = Open (DI KMB State = Open)
Large Motor start (Small Motor start)	DI KMA State = Open (DI KMB State = Open)

Table 4-39 Abnormal Contactor Conditions with Different Motor Conditions

Note:

During the power loss Ride-Through period, the Contactor Abnormal protection will be blocked (see **Section 4.17**).

The following figure illustrates the logic diagram for Contactor Abnormal protection.

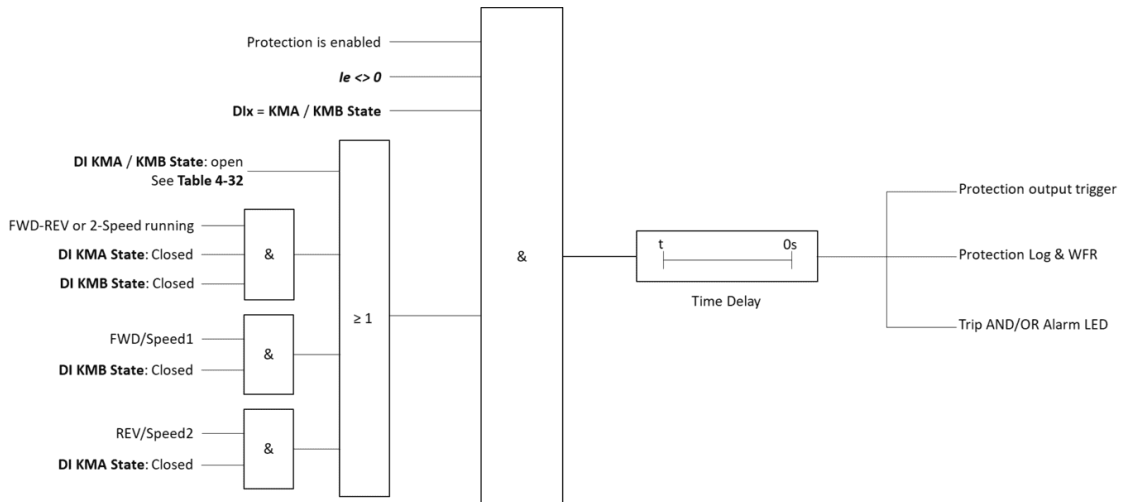

Figure 4-28 Logic Diagram for Contactor Abnormal Protection

4.4.5.10.2 Contactor Abnormal Setting

The following table describes the setting range and default values for the parameters of Contactor Abnormal Protection.

Setting Parameter	Range	Default
Config	OFF, Trip, Alarm, Trip + Alarm	OFF
Time Delay	0.10 to 99.99 s	5.00 s
Supplementary Output	R1 <input type="checkbox"/> R2 <input type="checkbox"/> R3 <input type="checkbox"/>	N/A

Table 4-40 Contactor Abnormal Parameter Settings

4.4.5.11 TC (Overtemperature) Protection

4.4.5.11.1 Overview

The relay can provide overtemperature protection for motors, control cabinets, busbars and contactors with the optional NTC sensor input on the PMC-KT module.

The relay provides two-level protection for each channel of temperature input with independent threshold and time delay settings.

The following figure illustrates the logical diagram for TC (Overtemperature) protection.

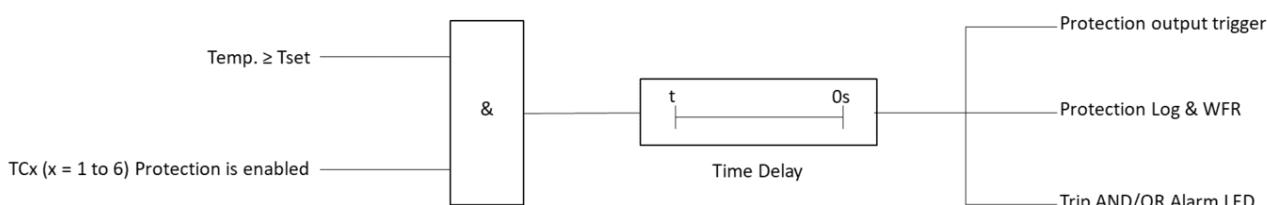

Figure 4-29 Logical Diagram of TC (Overtemperature) Protection

4.4.5.11.2 TC (Overtemperature) Protection Setting

The following table describes the setting range and default values for the parameters of TC (Overtemperature) Protection.

Setting Parameter	Range	Default
TCx (x = 1 to 6) Level I Protection		
Config	OFF, Trip, Alarm, Trip + Alarm	OFF
Pickup	20 to 150 (°C)	70
Time Delay	0.00 to 99.99 (s)	2.00
Supplementary Output	R1 <input type="checkbox"/> R2 <input type="checkbox"/> R3 <input type="checkbox"/>	N/A
TCx (x = 1 to 6) Level II Protection		
Config	OFF, Trip, Alarm, Trip + Alarm	OFF
Pickup	20 to 150 (°C)	100
Time Delay	0.00 to 99.99 (s)	2.00
Supplementary Output	R1 <input type="checkbox"/> R2 <input type="checkbox"/> R3 <input type="checkbox"/>	N/A

Table 4-41 TC (Overtemperature) Protection Setting Parameters

4.5 Local/Remote Control Mode

The relay allows manual start/stop of the motor in any of the following ways.

- 1) Start A, Start B, and Stop control signal inputs via DI
- 2) Start A, Start B, and Stop push buttons on the HMI module
- 3) Start A, Start B, and Stop register written via Modbus RTU protocol

The relay can either be in Local (e.g., a motor control panel with push buttons) or Remote (e.g., DCS or PLC, commands are transferred via cyclic communication telegrams) control mode at any time. The Local/Remote mode can be selected via the DI assigned for **Local/Remote**.

If neither DI is configured as the **Local/Remote** control switch, or the **DI Local/Remote** is in the **Local** position, the relay can respond to the Local Start / Stop / Forward / Reverse control signals. And if the **DI Local/Remote** control switch is in the **Remote** position, the relay can control the motor based on the Remote Start / Stop / Forward / Reverse control signals. The Local/Remote mode does not affect the Emergency Start / Stop and Forward /Reverse operations

The user can also use the control buttons on the HMI module to start/stop the motor based on the **Control Key** setting. When the **Control Key** is set to **Disable**, the control buttons are inactive. **Control Key** set to **Emergency** means the button control is always valid regardless of the DI **Local/Remote** value. And under other circumstances, the **Control Key** setting has to be consistent with the **DI Local/Remote** value to make the control buttons active. When neither DI is configured as **Local/Remote**, the **Control Key** has to be set to **Local** so that the control can make sense.

The relay can initiate a start/stop operation remotely via Modbus RTU communications when neither DI is configured as **Local/Remote** or the **DI Local/Remote** is in the **Remote** position.

4.6 Undervoltage Restart

To minimize production losses, it is possible to quickly restart the motor after an Undervoltage event or disturbance. This strategy aims to allow the low-voltage motors to restart within the pre-determined time and in a certain order when voltage is restored. These abnormal voltage conditions may be caused by cleared short-circuits upstream, generation and public supply voltage outages, or a simple automatic transfer system (ATS) of selective secondary substation operations.

The relay identifies the start of an Undervoltage event when Ullmax drops below the **Dip Threshold**, and the end of the event when Ullmin reaches the **Recover Voltage** or above. The relay has the capability to capture Undervoltage event at 10ms resolution.

Depending on the duration of an Undervoltage event, three possible conditions are considered:

- 1) A short Undervoltage event with the Duration shorter than the Quick Start Time (T_1). In this condition, the motor can restart immediately when the Voltage restores back and above the Recover Voltage setting.

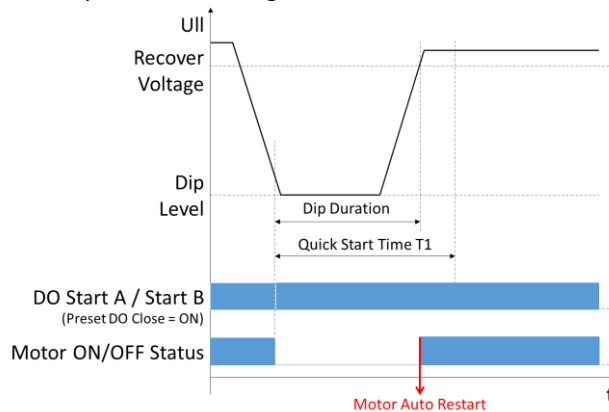
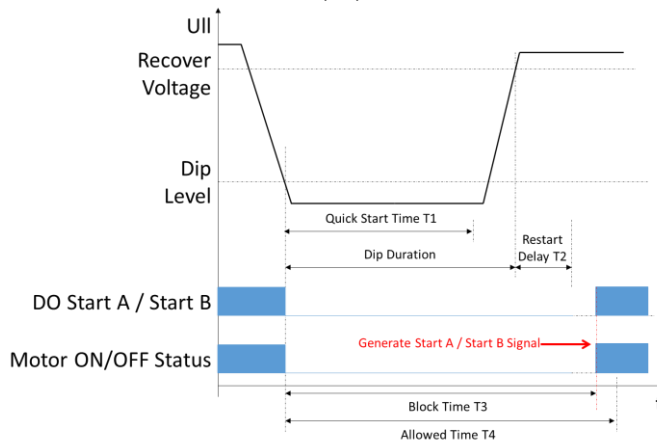

Figure 4-30 Motor Quick Start after the Voltage Dip Event

- 2) A prolonged Undervoltage with duration longer than the Quick Start Time (T_1) but within the Allowed Time (T_4) period. In this condition, the relay will generate a start command to the motor after the Restart Delay (T_2). If Start Block function is inhibited or the Block Time (T_3) is over, the motor can then be restarted successfully.



$T_4 \geq T_3 > T_1 + T_2$,
During the Block Time T_3 , any manual start request is ignored to maintain the operation of the Undervoltage Restart

Figure 4-31 Motor Undervoltage Restart after the Undervoltage Event

- 3) A long Undervoltage with duration longer than the Allowed Time (T_4). In this condition, the relay will not restart the motor via Undervoltage Restart logic. If the user wishes to restart the motor automatically once the voltage recovers, it is recommended to configure the Motor AutoRestart (see Section 4.7) or Device AutoRestart (see Section 4.8) functions.

The following table describes the parameters for **Undervoltage Restart** with setting range and default values.

Setting Parameter	Definition	Range, Default*
Dip Threshold	Voltage magnitude, indicating the start of a voltage dip.	0.30 to 0.95 (xUe), 0.75*
Recover Voltage	Voltage magnitude, indicating the end of a voltage dip.	0.80 to 1.60 (xUe), 0.85*
Quick Start		
Quick Start Time	Allowable duration for a short voltage dip. If the voltage recovers within this time, the motor can automatically restart. See Figure 4-30	0 to 9.99 (s), 2.50*
Preset DO Close	ON – Keep the contact of the motor start DO closed during the short voltage dip without checking if the voltage has been restored. OFF – The motor start DO will close automatically when the voltage is restored.	ON*, OFF
Pulse Width	In duration of Voltage Dip event, if you want the motor running DO signal to remain closed throughout the dip duration, the Pulse Width of this DO has to be greater than or equal to the Quick Start Time.	0 to 30.00 (s), 0.10*
Undervoltage Restart		
Config	Enable/disable the Undervoltage Restart feature.	ON, OFF*

Restart Delay	Minimum delay in restarting the motor after the voltage is restored. See Figure 4-31.	0.1 to 999.9 (s), 0.2*
Allowed Time	The allowable time for Undervoltage Restart. This time must be longer than the sum of the Quick Start Time and Restart Delay. If the voltage recovers within this time window, the motor can restart with the Undervoltage Restart logic. See Figure 4-31.	0.5 to 999.9 (s), 20.0*
Auxiliary DO	In soft-starter combined control applications, the Auxiliary DO offers a reset signal before restarting the soft-starter if needed.	N/A*, DO1, DO2, DO3, DO4, DO5, DO6
Auxiliary DO Delay	Delay in operating the Auxiliary DO after the voltage is restored.	0 to 99.99 (s), 0.0*
Block Time	Throughout the block time, the relay will inhibit all Undervoltage Restart commands. See Figure 4-31.	0 to 99.99 (s), 0*

Table 4-42 Undervoltage Restart Setting Parameters

Notes:

- 1) A zero value of **Quick Start Time** means Quick Start is disabled.
- 2) When the Auxiliary DO is used for soft-starter reset signal, the **Auxiliary DO Delay** shall be less than **Restart Delay**.
- 3) During a voltage dip, the supply voltage of the PMC-550D relay itself must be available! For special applications where the supply voltage is switched off, too, please refer to Section 4.8 Device Auto restart.

4.7 Motor AutoRestart

The motor auto restart logic detects whether the motor was running before the voltage interruption. After the motor voltage recovery is detected, the motor can be automatically restarted or restored to the previous state with a delay.

The following table describes the setting parameters for Motor AutoRestart.

Setting Parameter	Definitions	Range, Default*
Config	Enable/disable the Motor AutoRestart feature	ON, OFF*
Mode	Restart – Restart the motor, regardless of its previous state, before the voltage interruption. Recover – Restart the motor and recover it to the previous state (e.g., forwarding, reversing) before the voltage interruption.	Restart, Recover*
Delay	Delay in restarting or restoring the motor to the previous state after the motor voltage is restored.	0.1 to 999.9 (s), 25.0*

Table 4-43 Motor AutoRestart Setting Parameters

Notes:

1. If any start block conditions exist, the motor will fail to restart.
2. Detection criteria for the motor voltage recovery– voltage transition from Ullmin < **Dip Threshold** to Ullmin > **Recover Voltage**. For the **Dip Threshold** and **Recover Voltage** settings, please refer to **Section 4.6**.
3. The motor restart delay does not include the time for the relay’s initializing.
4. If the relay voltage and the motor voltage are interrupted simultaneously, the motor auto restart logic is activated after a delay of 10s from the time the relay voltage is restored.

4.8 Device AutoRestart

When the relay voltage and motor voltage come from the same source, the Device AutoRestart scheme can be used to restart the relay and the motor in a sequence once the voltage is restored.

The following table describes the setting parameters for Device AutoRestart.

Setting Parameter	Definitions	Range, Default*
Config	Enable/disable the Device AutoRestart feature	ON, OFF*
Mode	Restart – Restart the motor, regardless of its previous state, before the voltage interruption. Recover – Restart the motor and recover it to the previous state (e.g., forwarding, reversing) before the voltage interruption.	Restart, Recover*
Delay	Delay in restarting or restoring the motor to the previous state after the system voltage is restored.	0.1 to 99.99 (s), 0.1*

Table 4-44 Device Auto Restart Setting Parameters

Notes:

1. If any start block conditions exist, the motor will fail to restart.
2. If the motor voltage is not restored within 60s from the time the relay is restarted, the relay’s Device Auto restart logic will not restart the motor.
3. Detection criteria for the motor voltage recovery – voltage transition from Ullmin < **Dip Threshold** to Ullmin > **Recover Voltage**. For the **Dip Threshold** and **Recover Voltage** settings, please refer to **Section 4.6**.

4.9 Starter Function

Please refer to **Section 2.19** for the Wiring and DI/DO configurations for different Starter functions.

The following table describes the setting parameters for the starter modes with the setting range and default value.

PLEASE NOTE THAT MODIFICATION TO ANY STARTER FUNCTION PARAMETERS WILL STOP THE MOTOR.

Setting Parameter	Specifications/Definitions/Range	Default	
Mode	Defines the starter function based on the applications. Direct-On-Line, Reduce-volt., FWD/REV Start, 2-Speed Start, Inverter Coordinated Control, High-power Motor Auxiliary Control, Circuit Breaker Control, Motorized Value Control	Direct-On-Line	
CMD mode	0=Edge Trigger*, 1=Level Trigger	0=Edge Trigger	
DP control config	Enable/disable auto-stop on DP communication loss. 0=Off*, 1=On	0=Off	
DP control delay	Delay time before stopping after DP communication loss. 1-9999 (x0.1s)	50	
Reduce-voltage Start (Including Star-Delta Start, Auto-transformer Start and Resistance Start)			
Delay	Delay in switching the motor to full-voltage running from the Reduce-voltage start. The switch over from reduce-volt. start to full-volt. running takes place earliest after 1s delay, therefore, the delay must be set to at least 1 second. 1.00 to 99.99 (s)	25.00	
Iset	Specify the max. allowable current for Reduce-voltage start period. If Iset=0, the motor switches to full-volt. running from Reduce-voltage start once the Delay time is reached. 0.00 to 3.00 (xIe)	0	
Mode	In make-before-break (MBB) mode, DO Start A (Reduce-voltage) maintains closed until DO Start B (full-voltage) operates. While in break-before-make (BBM) mode, DO Start B operates after 1s delay since the DO Start A released. If motor $I_e < 0$ ($I_e \neq 0$) is detected after DO Start A released, the relay will alarm that the Reduce-voltage start is failed. Please note that make-before-break mode shall NOT be used in Star-Delta start. MBB, BBM	BBM	
FWD/REV Start			
Delay	Specify the minimum time before a start in the opposite direction is possible. 1.00 to 99.99 (s)	5.00	
2-Speed Start			
I1	Nominal current of motor for speed 1. 0.20 to 5.00 (xIe),	1.00	
I2	Nominal current of motor for speed 2. 0.20 to 5.00 (xIe)	0.50	
Delay	Specify the minimum time before a start at alternative speed is possible. 1.00 to 99.99 (s)	5.00	
Inverter Coordinated Control			
Delay	Defines the startup delay time for inverter coordinated control. 1-99.99 s	10	
High-power Motor Auxiliary Control			
Start control	Start block time	Start interval for sequential motor starting control. 0-9999 (s), (0 means disabled)	0
	Stop block time	Start-stop interval for sequential motor starting control. 0-9999 (s), (0 means disabled)	0
	Max. start count	Max consecutive starts for sequential motor control. 0-20, (0 means disabled)	0
	Interval	Start interval for sequential motor starting control. 1-9999 (min)	30
Delay	Start delay for large motor auxiliary control.	10	

	1-99.99 s	
Motorized Value Control		
Control Timeout	Control timeout for motorized valve operation. 0.1-6000 s	20
Start Timeout	Startup timeout for motorized valve control. 0.1-6000 s	8
DI Emergency	Enable/disable emergency motorized valve control via DI. 0=Off, 1=On	0=Off

Table 4-45 Start Control Mode Setting Parameters

4.10 Communication Test

The relay can verify the data, including **Relay Data, Metering Data, Harmonic, DI Status, DO Status** and **Protection Status**, uploading to the workstation/master via the **Communication Test** feature on the HMI module.

Once entering a specific sub-menu of the Communication Test menu, the data as displayed will be uploaded to the workstation/master for a momentary synchronization. The DI/DO status change or protection operation displayed on Communication Test won't cause any control logic to be active while the Trip/Alarm LED indicators will be illuminated. An event for **Communication Test ON** will be generated in SOE at the same time. Exiting the sub-menu means the Communication Test is completed. Another event for **Communication Test OFF** will be recorded in SOE.

Please note that under **Communication Test** mode, the metering and protection functions are not available. Therefore, the **Communication Test** must be only active for commissioning purposes.

4.11 Control Logic Test

During Control Logic Test, it's possible to keep the protective motor running without interruption and simultaneously verify the relay's DI, DO and protection logic.

Function	Descriptions
DI Logic Test	Test the control logic based on the DI settings by simulating the DI operated/released.
DO Logic Test	Test a contactor operation by manually operating/releasing the connected DO.
Protection Logic Test	Test the operation of a protection trigger based on the output settings by simulating the protection activated. The DO Trip and Alarm will be tested if a protection is set to OFF.

Table 4-46 Control Logic Test Descriptions

4.12 Programmable Logic

The relay supports the Programmable Logic (PL) via CET's PMC-Designer software with Function Block Diagram (FBD) programming language as described in *IEC 61131-3: Programmable controller – Part 3 Programming language*. The function block diagram consists of variable IEC function blocks (including Logic, Arithmetic, Comparison, Timer, and etc.) connecting with input and output variables (including Relay Data, Metering Data, DI, DO and etc.). The user can also create customized function blocks with self-defined variables via the platforms.

Here is an example.

Create the following FBD with a Timer delay function block, IN1 (DI1) input, DO3-O (DO3 open) output, and ALM_LAMP (Alarm LED) output variables via PMC-Designer and export to the connected PMC-550D. If an FBD is imported successfully to the relay, the symbol  will display on the default screen of the HMI module (see Section 3.4). When DI1 is closed, after 50ms delay, the DO3 will operate and the Alarm LED will light up.

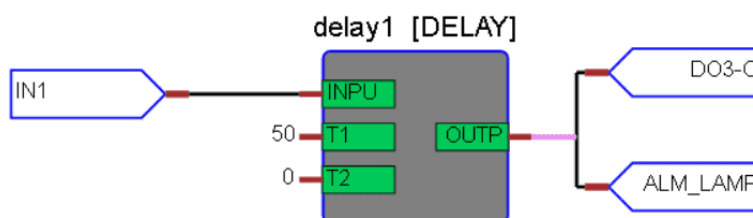

Figure 4-32 An Example of Programmable Logic Diagram

4.13 Metering and Monitoring

4.13.1 Metering

The relay metering data are classified into the following categories.

- Fundamental metering
- RMS metering
- Harmonic metering
- Temperature metering (optional)

4.13.1.1 U/I Metering Threshold

The relay applies a threshold for line voltage and current magnitude metering quantities to force a reading to zero when the measurement is near zero.

The threshold for current value is 2% * MTA secondary and for line voltage value is 10 * V secondary.

4.13.1.2 Fundamental Metering

The relay provides the following fundamental metering parameters through the HMI or communication access.

Relay Options	Metering Parameters
All Models	Line Voltages UAB, UBC, and UCA magnitudes (V) and phase angles (°) Average Line Voltage IA, IB, IC, magnitudes (A) and phase angles (°) Average Current Iavg IA/Ie ratio (%), IB/Ie ratio (%), IC/Ie ratio (%) and Iavg/Ie ratio (%) Residual Current IR (mA) I1 (positive sequence), I2 (negative sequence) Calculated Neutral Current (3I0) Total kW, Total kvar, Total kVA and PF Current Unbalance (%) Cooling Time (s) and Heat Capacity (%) System Frequency Thermal Resistance

Table 4-47 Fundamental Metering Parameters

4.13.1.3 RMS Metering

The relay provides the following RMS metering at which the motor is running.

Parameters	Phase A	Phase B	Phase C	Total
ULL	●	●	●	--
U Phase Angle	●	●	●	--
I	●	●	●	--
I Phase Angle	●	●	●	--
I/Ie (%)	●	●	●	--
P	--	--	--	●
Q	--	--	--	●
PF	--	--	--	●
kWh Import/Export	--	--	--	●
kvarh Import/Export	--	--	--	●

Table 4-48 RMS Metering Parameters

4.13.1.4 Temperature Metering

If the relay is equipped with the optional PMC-KT module, the TC1 to TC6 temperature metering will be displayed under **Meter - > Temperature** menu on the HMI display.

4.13.1.5 Harmonic Metering

The following table illustrates the voltage and current harmonics measurements on the relay.

Parameters	Phase A	Phase B	Phase C
Voltage / Current Harmonics	THD	THD	THD
	TOHD	TOHD	TOHD
	TEHD	TEHD	TEHD

	2 nd Harmonic	2 nd Harmonic	2 nd Harmonic

	31 st Harmonic	31 st Harmonic	31 st Harmonic

Table 4-49 Harmonic Metering Parameters

4.13.2 Statistic

The relay stores the latest machine operating statistics information for the maintenance of the protected motor in its non-volatile memory. All statistics information will be cleared via Clear Statistics operation on the HMI or through communications.

Menu	Parameters	Unit
Statistics	Trip IA, Trip IB and Trip IC (trip current)	A
	Trip Times (total counter for protection trips)	--
	Start I (start current for the last start)	A
	Start Time (for the last start)	s
	Start Counter	--
	Total Running Time	h
	Running Time (from the last start)	h
	Total Stop Time	h
	Stop Time (from the last stop)	h
	Device Running Time	h
	IR (for the last start)	mA
IN (for the last start)	A	

Table 4-50 Statistics Information

4.13.3 SOE (Sequence of Events)

The relay’s SOE Log can store up to 64 events, such as DI/DO Logs, Diagnostic (self-check result) Logs and Maintenance Logs. If there are more than 64 events, the newest event will replace the oldest event on a First-in-First-out basis. All events are stored in the relay’s non-volatile memory. Each event record includes the event classification, its relevant parameter values and a timestamp in 1ms resolution. Please refer to **Appendix A – SOE and Protection Log Classifications** for the details.

All events are available via the HMI or through communications. The SOE Log can be reset from the HMI or via communications.

4.13.4 Protection Log

The relay’s Protection Log can store up to 64 events, such as protection trip/alarm, Undervoltage restart fail, invalid start command, etc. If there are more than 64 events, the newest event will replace the oldest event on a First-in-First-out basis. All the events are stored in the relay’s non-volatile memory. Each event record includes the event classifications, its relevant parameter values and a timestamp in 1ms resolution. Please refer to **Appendix A – SOE and Protection Log Classifications** for the details.

All events are available via the HMI or through communications. The Protection Log can be reset from the HMI or via communications.

4.13.5 Start Report

The relay records motor start data for each motor start. The relay can store up to 64 motor start reports in non-volatile memory. The Start Report provides the following information.

- Start control source – Dlx control, HMI control, and etc. See **Table 4-51**.
- Maximum start current
- Minimum start voltage
- Motor start time
- Timestamp
- Start result – succeeded or failed

The relay calculates the motor start time from the time the start detection criteria is satisfied until the running state is detected (see **Section 4.4.3 Motor States**).

The following table concludes all the motor start control sources recorded in Start Report.

1	Dlx control	4	Profibus control	7	AutoRestart	10	Unknown source
2	HMI control	5	PLC control	8	External control	11	Profinet Control
3	Modbus control	6	Under-volt. restart	9	Quick restart		

Table 4-51 Motor Start Control Source

4.13.6 Stop Report

The relay records motor stop data for each motor stop. The relay can store up to 64 motor stop records in non-volatile memory. The Stop Report provides the following information.

- Stop control source – Dlx control, HMI control, Modbus control, Profibus control, PLC control, and etc.
- IA, IB, IC magnitude
- Timestamp

The following table concludes all the motor stop control sources recorded to Stop Report.

1	Dlx control	5	PLC control	9	Control para. update	13	Protection trip
2	HMI control	6	Voltage interruption	10	Switch direction	14	Unknown source
3	Modbus control	7	DP control	11	Change speed	15	Profinet Control
4	Profibus control	8	External control	12	Lock start		

Table 4-52 Motor Stop Control Source

4.13.7 Insulation Test

With the optional PMC-KR module, the relay can test the insulation resistance between the motor windings, or any conductor terminal with respect to the ground terminal, by applying a DC voltage to the test load device. Depending on the system voltage, the relay supplies a 500VDC or 1000VDC automatically, with no need to define the test voltage level.

The user may select the working mode of the insulation test, auto or manual. In auto mode, the relay automatically test the insulation resistance in a preset interval. In manual mode, the user can start/stop the insulation test via the HMI module or communications.

At the start of each insulation resistance test, the relay performs a voltage test to confirm that no hazardous voltage (>30V) is detected. If there is, the relay will block the insulation test and display the block reason on the HMI module.

During the insulation test, the motor must be completely de-energized. Otherwise, the insulation test will be stopped with a result of '0x7FFF' meaning invalid. If a motor start command is received when the insulation test has not been completed, the relay stops the insulation test and starts the motor with a 2s delay.

The HMI shows the insulation resistance and testing voltage after the circuit stabilizes. There are 3 possible conditions:

- Resistance displayed is $\leq 100M\Omega$.
- Resistance measured is $> 100M\Omega$ and resistance displayed is 0xFFFF.
- Resistance displayed is 0x7FFF, which is invalid.

The relay can store up to 500 logs for the insulation tests with the timestamp on a first-in-first-out basis. And on the HMI module, the user can check the latest 8 test results under the **Logs -> Insulation Logs** menu.

4.14 Self-check

Once connected to power, the relay does a continual internal self-check to verify its hardware status. If any of the faults illustrated in Table 4-53 is detected, the relay takes the following actions for correction:

- Alarm LED is illuminated.
- Optional Self-check output will be de-energized.
- The HMI displays the latest failure type message automatically.
- Disable protections. The relay disables protection and control elements as well as trip/close logic.

Diagnostic Result	Metering Error Fault channel – UAB, UBC, UCA, IA, IB, IC and IR
	Device Parameter Error
	Protection Parameter Error
	Calibration Parameter Error
	Setup Parameter Error
	FRAM Error
	FLASH Error

Table 4-53 Self-Check Diagnostics

The user can access all self-check information via **Log -> Diagnostics** menu on the HMI or in SOE (see **section 5.8.2**) through Communications.

4.15 Wiring Diagnosis

The relay provides wiring error detection and allows the user to check for potential problems, especially during the initial commissioning stage. The user can access the wiring diagnosis result via **Maint.** -> **Diagnosis** menu on the HMI. The following wiring errors may be detected:

- Voltage phase reversal
- Current phase reversal
- Incorrect MTA direction

4.16 WFR (Waveform Recorder)

The PMC-550D supports the waveform recording of 3-phase RMS line voltages (ULL), current (I), as well as neutral current (3IO) at a resolution of 2 samples/cycle. The WFR has a fixed length of 850 cycles with a pre-fault-cycle of 100. WFR on the PMC-550D can be triggered by protection active, motor start or manually triggered through the HMI and communications. The manual trigger command has a higher priority. When a WFR is already in progress, other WFR commands will be ignored until the present recording has been completed. The WFR has a capacity of 16 entries organized on a FIFO basis, with the newest WFR log replacing the oldest one. The WFR log is stored in the device's non-volatile memory in COMTRADE file format and will not suffer any loss in the event of power failure.

The WFR log can be downloaded via CET's PMC-EasyConfig or other communications and subsequently viewed using software that supports these industry standard file formats. The following figure shows a waveform recorded for the motor start event.

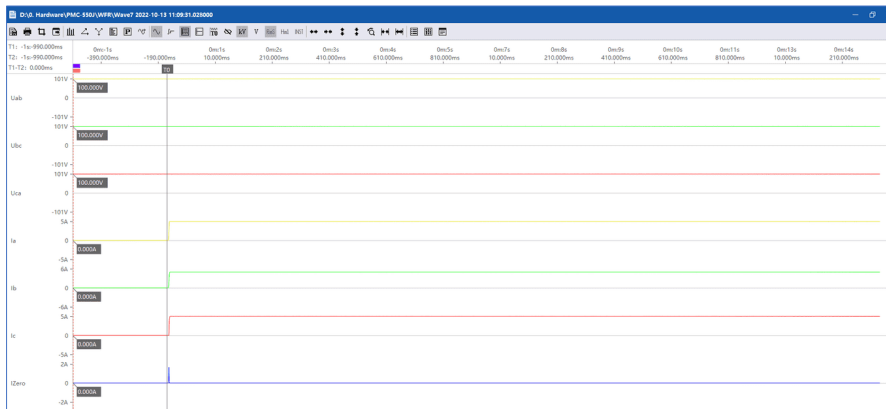

Figure 4-33 Waveform Log for a Motor Start Event

4.17 Enhanced Power Supply

The relay equips with an enhanced power supply with 30 seconds ride-through capability to cater for supply interruption.

During the ride-through period, the metering, part of the control and protection for the motor will continue to function normally. While the following operations will fail to execute due to power loss.

- Relay's parameters setup
- Energy accumulation
- HMI display
- DI Status/Control signal input
- AO output

Chapter 5 Modbus Map

This chapter provides a complete description of the Modbus register map (**Protocol Version 3.1**) for the PMC-550D to facilitate the development of 3rd party Modbus RTU communications driver for accessing the information on the relay.

The PMC-550D supports the following Modbus functions:

- 1) Read Holding Registers (Function Code 0x03)
- 2) Force Single Coil (Function Code 0x05)
- 3) Preset Multiple Registers (Function Code 0x10)

For a complete Modbus Protocol Specification, please visit <http://www.modbus.org>.

The following table provides a description of the different data formats used for the Modbus registers. The PMC-550D uses the Big-Endian byte ordering system.

Format	Description
UINT16/INT16	Unsigned/signed 16-bit integer
UINT32/INT32	Unsigned/signed 32-bit integer
INT64	Signed 64-bit integer
FLOAT	IEEE 754 32-bit floating point number (single precision)
BITMAP	16-bit/32-bit binary register where each bit represents a specific quantity
CHAR	16-bit binary register which represents a single Unicode character.

5.1 Real-time Relay Data

Register	Property	Description	Format	Unit	Note
0000	RO	Protection log pointer	UINT32		
0002	RO	SOE log pointer	UINT32		
0004	RO	Start report pointer	UINT32		
0006	RO	Stop report pointer	UINT32		
0008	--	Reserved	--		
0010	RO	Waveform log pointer	UINT32		
0012	RO	Insulation log pointer	UINT32		
0014	--	Reserved	--		
0016	RO	DI status	BITMAP		BIT0~BIT11: DI1~DI12, 0=Inactive, 1=Active
0017	RO	DO status	BITMAP		BIT0~BIT5: DO1~DO6, 0=Released, 1=Operated
0018	RO	Protection trip status	UINT16		0=No Trip, 1=Protection Trip
0019	RO	Protection alarm status	UINT16		0=No Alarm, 1=Protection Alarm
0020	RO	Trip source 1 (manual reset)	BITMAP		See Note 1
0021	RO	Trip source 2 (manual reset)	BITMAP		See Note 1
0022	RO	Trip source 3 (manual reset)	BITMAP		See Note 1
0023	RO	Trip source 4 (manual reset)	BITMAP		See Note 1
0024	--	Reserved	--		
0025	RO	Alarm source 1 (manual reset)	BITMAP		See Note 2
0026	RO	Alarm source 2 (manual reset)	BITMAP		See Note 2
0027	RO	Alarm source 3 (manual reset)	BITMAP		See Note 2
0028	RO	Alarm source 4 (manual reset)	BITMAP		See Note 2
0029	--	Reserved	--		
0030	RO	Self-check status	BITMAP		BIT0=Analog/Digital Metering, BIT1=Device Parameter BIT2=Protection Parameter BIT3=FRAM BIT4=FLASH 0=Normal, 1=Error
0031	RO	Trip source 1 (auto reset)	BITMAP		
0032	RO	Trip source 2 (auto reset)	BITMAP		
0033	RO	Trip source 3 (auto reset)	BITMAP		
0034	RO	Trip source 4 (auto reset)	BITMAP		
0035	--	Reserved	--		
0036	RO	Alarm source 1 (auto reset)	BITMAP		
0037	RO	Alarm source 2 (auto reset)	BITMAP		
0038	RO	Alarm source 3 (auto reset)	BITMAP		
0039	RO	Alarm source 4 (auto reset)	BITMAP		
0040	--	Reserved	--		

0041	RO	Wiring diagnosis	BITMAP		BIT0=Voltage Reversal BIT1=Current Reversal BIT2=IA/IB Switched BIT3=IA/IC Switched BIT4=IB/IC Switched BIT5=MTA Wrong Direction 0=invalid (normal), 1=valid (error)
0042	--	PLC variable status	BITMAP		BIT0~BIT15: VARB1~VARB16, 1=valid
0043	RO	PLC trip (manual reset)	BITMAP		
0044	RO	PLC alarm (manual reset)	BITMAP		
0045	RO	PLC trip ACB (manual reset)	BITMAP		
0046	RO	PLC trip (auto reset)	BITMAP		
0047	RO	PLC alarm (auto reset)	BITMAP		
0048	RO	PLC trip ACB (auto reset)	BITMAP		
0049~0050	--	Reserved	--		
0051	RO	Ready to start the motor	UINT16		0=No, 1=Yes
0052	RO	Fundamental UAB	FLOAT	V	
0054	RO	Fundamental UBC	FLOAT	V	
0056	RO	Fundamental UCA	FLOAT	V	
0058	RO	Fundamental ULL Average	FLOAT	V	
0060	RO	Fundamental IA	FLOAT	A	
0062	RO	Fundamental IB	FLOAT	A	
0064	RO	Fundamental IC	FLOAT	A	
0066	RO	Fundamental I Average	FLOAT	A	
0068	RO	Fundamental I1 (positive sequence)	FLOAT	A	
0070	RO	Fundamental I2 (negative sequence)	FLOAT	A	
0072	RO	Fundamental 3I0 (zero sequence)	FLOAT	A	
0074	RO	Fundamental kW	FLOAT	kW	
0076	RO	Fundamental kvar	FLOAT	kvar	
0078	RO	Fundamental kVA	FLOAT	kVA	
0080	RO	Fundamental PF	FLOAT		
0082	RO	Frequency	FLOAT	Hz	
0084	RO	Fundamental IN	FLOAT	A	
0086	RO	IR	FLOAT	mA	
0088	--	Reserved	--		
0090	RO	Current imbalance	FLOAT	%	
0092	RO	UAB phase angle	FLOAT	°	
0094	RO	UBC phase angle	FLOAT	°	
0096	RO	UCA phase angle	FLOAT	°	
0098	RO	IA phase angle	FLOAT	°	
0100	RO	IB phase angle	FLOAT	°	
0102	RO	IC phase angle	FLOAT	°	
0104	RO	IA/Ie	FLOAT	%	
0106	RO	IB/Ie	FLOAT	%	
0108	RO	IC/Ie	FLOAT	%	
0110	RO	I Average/Ie	FLOAT	%	
0112	RO	Thermal overload alert time delay	UINT32	s	x0.1
0114	RO	Thermal overload cooling time	UINT32	s	x0.1
0116	RO	Heat capacity (used)	UINT16	%	x0.1
0117	RO	Motor state	UINT16		0=Stop, 1=Start, 2=Running, 3=Forward, 4=Reverse, 5=Speed 1, 6=Speed 2
0118	RO	Programmable logic data 1	FLOAT		VARA1
0120	RO	Programmable logic data 2	FLOAT		VARA2
0122	RO	Programmable logic data 3	FLOAT		VARA3
0124	RO	Programmable logic data 4	FLOAT		VARA4
0126	RO	Overload Protection Equivalent Current	FLOAT	A	
0128~0132	-	Reserved	--		
0134	RO	TC1	UINT16	°C	x0.1
0135	RO	TC2	UINT16	°C	x0.1
0136	RO	TC3	UINT16	°C	x0.1
0137	RO	TC4	UINT16	°C	x0.1
0138	RO	TC5	UINT16	°C	x0.1
0139	RO	TC6	UINT16	°C	x0.1

0140	RO	Insulation Resistance	UINT16	MΩ	x0.01
------	----	-----------------------	--------	----	-------

Table 5-1 Real-time Relay Data

Notes:

- The following table illustrates the details for Trip source 1-4 (auto/manual reset) with a bit value of “1” meaning protection active.

Source 1							
BIT	Protection	BIT	Protection	BIT	Protection	BIT	Protection
Bit0	Long Start	Bit4	Phase Current Loss	Bit8	Undervoltage	Bit12	Overload
Bit1	Thermal Overload	Bit5	Imbalance	Bit9	Overvoltage	Bit13	Interlock
Bit2	Jam	Bit6	Under Power	Bit10	Underload	Bit14	Reserved
Bit3	Ground Fault	Bit7	Short Circuit	Bit11	tE Time	Bit15	Phase Reversal
Source 2							
BIT	Protection	BIT	Protection	BIT	Protection	BIT	Protection
Bit0	Closed-loop Abnormal	Bit4	Contactors Failure	Bit8	Negative Sequence	Bit12	Reserved
Bit1	Contactors Abnormal	Bit5	ACB Trip Contactors	Bit9	Reserved	Bit13	Reserved
Bit2	Reserved	Bit6	Residual Current I	Bit10	Insulation Resistance	Bit14	Reserved
Bit3	Reserved	Bit7	Residual Current II	Bit11	Reserved	Bit15	Reserved
Source 3							
BIT	Protection	BIT	Protection	BIT	Protection	BIT	Protection
Bit0	Thermo	Bit4	TC1 II	Bit8	TC3 II	Bit12	TC5 II
Bit1	Reserved	Bit5	TC2 I	Bit9	TC4 I	Bit13	TC6 I
Bit2	Reserved	Bit6	TC2 II	Bit10	TC4 II	Bit14	TC6 II
Bit3	TC1 I	Bit7	TC3 I	Bit11	TC5 I	Bit15	Reserved
Source 4							
BIT	Protection	BIT	Protection	BIT	Protection	BIT	Protection
Bit0	Reserved	Bit4	Reserved	Bit8	Dual over-torque fault	Bit12	Reserved
Bit1	Reserved	Bit5	Limit position error	Bit9	Motor valve control timeout	Bit13	Reserved
Bit2	Reserved	Bit6	Dual limit switch fault	Bit10	Reserved	Bit14	Reserved
Bit3	Reserved	Bit7	Motor valve locked-rotor	Bit11	Reserved	Bit15	Reserved

Table 5-2 Trip Source 1-4 Details

- The following table illustrates the details for Alarm source 1 to 4 (auto/manual reset) with a bit value of “1” meaning protection active.

Source 1							
BIT	Protection	BIT	Protection	BIT	Protection	BIT	Protection
Bit0	Long Start	Bit4	Phase Current Loss	Bit8	Undervoltage	Bit12	Overload
Bit1	Thermal Overload	Bit5	Imbalance	Bit9	Overvoltage	Bit13	Interlock
Bit2	Jam	Bit6	Under Power	Bit10	Underload	Bit14	LOP
Bit3	Ground Fault	Bit7	Short Circuit	Bit11	tE Time	Bit15	Phase Reversal
Source 2							
BIT	Protection	BIT	Protection	BIT	Protection	BIT	Protection
Bit0	Closed-loop Abnormal	Bit4	Reserved	Bit8	Negative Sequence	Bit12	Reserved
Bit1	Contactors Abnormal	Bit5	Reserved	Bit9	Thermal OL Alert	Bit13	Reserved
Bit2	Emergency Stop	Bit6	Residual Current I	Bit10	Insulation Resistance	Bit14	Reserved
Bit3	MTA Failure	Bit7	Residual Current II	Bit11	Reserved	Bit15	Reserved
Source 3							
BIT	Protection	BIT	Protection	BIT	Protection	BIT	Protection
Bit0	Thermo	Bit4	TC1 II	Bit8	TC3 II	Bit12	TC5 II
Bit1	Short cct Alarm	Bit5	TC2 I	Bit9	TC4 I	Bit13	TC6 I
Bit2	Open cct Alarm	Bit6	TC2 II	Bit10	TC4 II	Bit14	TC6 II
Bit3	TC1 I	Bit7	TC3 I	Bit11	TC5 I	Bit15	TC1 Abnormal
Source 4							
BIT	Protection	BIT	Protection	BIT	Protection	BIT	Protection
Bit0	TC2 Abnormal	Bit4	TC6 Abnormal	Bit8	Reserved	Bit12	Reserved
Bit1	TC3 Abnormal	Bit5	Reserved	Bit9	Reserved	Bit13	Reserved
Bit2	TC4 Abnormal	Bit6	Reserved	Bit10	Reserved	Bit14	Reserved
Bit3	TC5 Abnormal	Bit7	Reserved	Bit11	Reserved	Bit15	Reserved

Table 5-3 Alarm Source 1 to 4 Details

5.2 Statistic

Register	Property	Description	Format	Unit	Note
0200	RO	Trip IA	UINT32	A	x0.001
0202	RO	Trip IB	UINT32	A	x0.001
0204	RO	Trip IC	UINT32	A	x0.001
0206	RO	Maximum start current	INT32	A	x0.001
0208	RO	Maximum 3I0 during start	INT32	A	x0.001
0210	RO	Maximum IR during start	INT32	mA	
0212	RO	Start time (for the last start)	UINT16	s	x0.01
0213	RO	Start counter	UINT16		

0214	RO	Trip times (total counter for protection trips)	UINT16	-	
0215	RO	Total running time	UINT32	h	
0217	RO	Running time (from the last start)	UINT32	h	
0219	RO	Total stop time	UINT32	h	
0221	RO	Stop time (from the last stop)	UINT32	h	
0223	RO	Device running time	UINT32	h	
0225	RO	Start block remaining time	UINT32	s	
0227	RO	Stop block remaining time	UINT32	s	
0229	RO	Max. start counter block remaining time	UINT32	s	
0231	RO	Insulation resistance measured last time	UINT16	MΩ	x0.01

Table 5-4 Statistic Data

5.3 Real-time Metering Data

Register	Property	Description	Format	Unit	Note
0300	RO	Uab	FLOAT	V	
0302	RO	Ubc	FLOAT	V	
0304	RO	Uca	FLOAT	V	
0306	RO	Ull average	FLOAT	V	
0308	RO	Ia	FLOAT	A	
0310	RO	Ib	FLOAT	A	
0312	RO	Ic	FLOAT	A	
0314	RO	I average	FLOAT	A	
0316	RO	P	FLOAT	kW	
0318	RO	Q	FLOAT	kvar	
0320	RO	S	FLOAT	kVA	
0322	RO	PF	FLOAT		
0324	RO	Ia/Ie	FLOAT	%	
0326	RO	Ib/Ie	FLOAT	%	
0328	RO	Ic/Ie	FLOAT	%	
0330	RO	I average/Ie	FLOAT	%	

Table 5-5 Real-time Metering Data

5.4 Energy Measurement

Register	Property	Description	Format	Unit	Note
0500	RW	kWh Import	INT32	kWh	x0.01
0502	RW	kvarh Import	INT32	kvarh	x0.01
0504	RW	kWh Export	INT32	kWh	x0.01
0506	RW	kvarh Export	INT32	kvarh	x0.01

Table 5-6 Energy Measurement

5.5 Harmonic

Register	Property	Description	Format	Unit	Note
0900	RO	I2 Imbalance	FLOAT	%	
0902	RO	Uab THD	FLOAT	%	
0904	RO	Uab TOHD	FLOAT	%	
0906	RO	Uab TEHD	FLOAT	%	
0908	RO	Ubc THD	FLOAT	%	
0910	RO	Ubc TOHD	FLOAT	%	
0912	RO	Ubc TEHD	FLOAT	%	
0914	RO	Uca THD	FLOAT	%	
0916	RO	Uca TOHD	FLOAT	%	
0918	RO	Uca TEHD	FLOAT	%	
0920	RO	Ia THD	FLOAT	%	
0922	RO	Ia TOHD	FLOAT	%	
0924	RO	Ia TEHD	FLOAT	%	
0926	RO	Ib THD	FLOAT	%	
0928	RO	Ib TOHD	FLOAT	%	
0930	RO	Ib TEHD	FLOAT	%	
0932	RO	Ic THD	FLOAT	%	
0934	RO	Ic TOHD	FLOAT	%	
0936	RO	Ic TEHD	FLOAT	%	

Table 5-7 Harmonic Measurement

5.6 Individual Harmonics

Register	Property	Description	Format	Unit	Note
1000	RO	UAB THD	FLOAT	%	
1002	RO	UAB TOHD	FLOAT	%	
1004	RO	UAB TEHD	FLOAT	%	
1006	RO	UAB HD02	FLOAT	%	
1008	RO	UAB HD03	FLOAT	%	
...	RO	...	FLOAT	%	
1064	RO	UAB HD31	FLOAT	%	
1066	RO	UBC THD	FLOAT	%	
1068	RO	UBC TOHD	FLOAT	%	
1070	RO	UBC TEHD	FLOAT	%	
1072	RO	UBC HD02	FLOAT	%	
1074	RO	UBC HD03	FLOAT	%	
...	RO	...	FLOAT	%	
1130	RO	UBC HD31	FLOAT	%	
1132	RO	UCA THD	FLOAT	%	
1134	RO	UCA TOHD	FLOAT	%	
1136	RO	UCA TEHD	FLOAT	%	
1138	RO	UCA HD02	FLOAT	%	
1140	RO	UCA HD03	FLOAT	%	
...	RO	...	FLOAT	%	
1196	RO	UCA HD31	FLOAT	%	
1198	RO	IA THD	FLOAT	%	
1200	RO	IA TOHD	FLOAT	%	
1202	RO	IA TEHD	FLOAT	%	
1204	RO	IA HD02	FLOAT	%	
1206	RO	IA HD03	FLOAT	%	
...	RO	...	FLOAT	%	
1262	RO	IA HD31	FLOAT	%	
1264	RO	IB THD	FLOAT	%	
1266	RO	IB TOHD	FLOAT	%	
1268	RO	IB TEHD	FLOAT	%	
1270	RO	IB HD02	FLOAT	%	
1272	RO	IB HD03	FLOAT	%	
...	RO	...	FLOAT	%	
1328	RO	IB HD31	FLOAT	%	
1330	RO	IC THD	FLOAT	%	
1332	RO	IC TOHD	FLOAT	%	
1334	RO	IC TEHD	FLOAT	%	
1336	RO	IC HD02	FLOAT	%	
1338	RO	IC HD03	FLOAT	%	
...	RO	...	FLOAT	%	
1396	RO	IC HD31	FLOAT	%	

Table 5-8 Individual Harmonics

5.7 Device Setting

5.7.1 System Setting

Register	Property	Description	Format	Range/Options, Default*
6000	RW	MTA connected	UINT16	0=No, 1=Yes*
6001	--	Reserved	--	
6002	RW	MTA type ¹	UINT16	1-5000 (A), 100*
6003	RW	Phase TA ratio ²	UINT16	1-5000, 1*
6004	RW	Ie ³	UINT32	1-60000 (x0.1A), 1000*
6006	RW	Primary Ue	UINT16	100-800 (V), 380*
6007	RW	Secondary Ue	UINT16	100-800 (V), 380*
6008	RW	Control key	UINT16	0=Disabled*, 1=Emergency, 2=Local, 3=Remote
6009	RW	DO Remote	UINT16	0=OFF*, 1=ON
6010	RW	Language	UINT16	0=Chinese, 1=English*
6011	RW	Ia polarity	UINT16	
6012	RW	Ib polarity	UINT16	0=Normal*, 1=Reverse
6013	RW	Ic polarity	UINT16	
6014	RW	Voltage sequence	UINT16	0=ABC*, 1=CBA
6015	RW	Current sequence	UINT16	0=ABC*, 1=CBA, 2=ACB, 3=CAB, 4=BAC, 5=BCA
6016	RW	Enable PLC	UINT16	0=No, 1=Yes*
6017	RW	Enable PMC-KT module	UINT16	0=No*, 1=Yes
6018	RW	Enable PMC-KR module	UINT16	0=No*, 1=Yes

6019	RW	Start hold time	UINT16	5-9999 (x0.01s), 200*
6020	RW	Starting current threshold	UINT16	100-800 (x0.01Ie), 110*
6021	RW	Starting current return threshold	UINT16	30-200 (x0.01Ie), 110*
6022	RW	Reserved	UINT16	
6023	RW	Communication Motor Control Authority	UINT16	0=No*, 1=Yes
6024	RW	QF Status Blocked Startup	UINT16	0=No*, 1=Yes
6025	RW	Reserved	UINT16	

Table 5-9 System Setting

Notes:

- The following table illustrates the recommended PMC-MTA type based on the rated Current and Power.

MTA Type	Rated kW	Rated Current
PMC-MTA-1A	< 0.4 kW	0.2 – 1 A
PMC-MTA-5A	0.4 – 2.2 kW	1 – 5 A
PMC-MTA-25A	2.2 – 12.5 kW	5 – 25 A
PMC-MTA-100A	12.5 – 50 kW	25 – 100 A
PMC-MTA-300A	50 – 150 kW	100 – 300 A
PMC-MTA-400A-T	120 – 200 kW	240 – 400 A
PMC-MTA-800A-T	160 – 400 kW	320 – 800 A

Table 5-10 Recommended PMC-MTA Type

- In some applications, it is required to use an additional protection current transformer (TA) to transform the circuit current to the relay's PMC-MTA Input. And the **Phase TA Ratio** should be set based on the Primary and Secondary of the protection current transformer. For example, to protect a LV motor rated at 500kW, 1200A, the Primary Input and Secondary Output of the used protection current transformer can be 1200A, 5A, respectively. The **Phase TA Ratio** should be set as $(1200A/5A) = 240$. Please note that **MTA Type x Phase TA Ratio** ≤ 5000.
- The following table illustrates that the motor rated Current **Ie** has a setting range based on **Z = MTA Type x Phase TA Ratio**.

Z	Ie Setting Range
< 100	0.1 – 1.2 (*Z)
≥ 100	0.2 – 1.2 (*Z)

Table 5-11 Motor Rated Current Ie Setting Range

5.7.2 Communication Setting

Register	Property	Description	Format	Range/Options, Default*
6100	RW	P1 (RS-485) unit ID	UINT16	1-247, 1*
6101	RW	P1 (RS-485) baudrate	UINT16	0=1200bps, 1=2400bps, 2=4800bps, 3=9600bps*, 4=19200bps
6102	RW	P1 (RS-485) data format	UINT16	0=8N2, 1=8O1, 2=8E1*, 3=8N1, 4=8O2, 5=8E2
6103	RW	P2 (RS-485) unit ID	UINT16	1-247, 1*
6104	RW	P2 (RS-485) baudrate	UINT16	0=1200bps, 1=2400bps, 2=4800bps, 3=9600bps*, 4=19200bps
6105	RW	P2 (RS-485) data format	UINT16	0=8N2, 1=8O1, 2=8E1*, 3=8N1, 4=8O2, 5=8E2
6106	RW	Profibus DP 1 communication ID	UINT16	1-125, 1*
6107	RW	Profibus DP 1 communication baudrate	UINT16	0=9.6kbps, 1=19.2kbps, 2=42.45kbps, 3=93.75kbps, 4=187.5kbps, 5=500kbps, 6=1500kbps*
6108	RW	Profibus DP 2 communication ID	UINT16	1-125, 1*
6109	RW	Profibus DP 2 communication baudrate	UINT16	0=9.6kbps, 1=19.2kbps, 2=42.45kbps, 3=93.75kbps, 4=187.5kbps, 5=500kbps, 6=1500kbps*
6110	RW	Modbus TCP Address Validation	UINT16	0=No*, 1=Yes
6111	RW	Modbus TCP unit ID	UINT16	1-247, 1*
6112	RW	Port Mode	UINT16	0=Independent Dual Network*, 1=Switch
6113	RW	IP1 Address 1	UINT16	0.0.0.0~255.255.255.255 192.168.0.100*
6114	RW	IP1 Address 2	UINT16	
6115	RW	IP1 Address 3	UINT16	
6116	RW	IP1 Address 4	UINT16	
6117~6120	RW	MASK1 Address 1-4	UINT16	0.0.0.0~255.255.255.255 255.255.255.0*
6121~6124	RW	IP1 Address 1-4	UINT16	0.0.0.0~255.255.255.255 192.168.1.100*
6125~6128	RW	MASK2 Address 1-4	UINT16	0.0.0.0~255.255.255.255 255.255.255.0*
6129~6132	RW	Gateway	UINT16	0.0.0.0~255.255.255.255 192.168.0.1*
6133~6136	RW	SNTP Time Server Address 1-4	UINT16	0.0.0.0~255.255.255.255 127.0.0.1*
6137	RW	SNTP Time Synchronization Interval	UINT16	0~9999min, 1*

6138	RW	System Time Zone	UINT16	-720~780min, 480*
6139	RW	RS-485 Expand port type	UINT16	0=Modbus slave, 1=Modbus master*
6140	RW	RS-485 Expand port unit ID	UINT16	1-247, 1*
6141	RW	RS-485 Expand port baudrate	UINT16	0=1200bps, 1=2400bps, 2=4800bps, 3=9600bps*, 4=19200bps
6142	RW	RS-485 Expand port data format	UINT16	0=8N2, 1=8O1, 2=8E1*, 3=8N1, 4=8O2, 5=8E2
6143	RW	RS-485 Expand port switching delay	UINT16	0 to 2000 (ms), 60*

Table 5-12 Communication Setting

5.7.3 Protection Setting

Register	Property	Description	Format	Range/Options, Default*
6150	RW	Trip reset mode	UINT16	0= Auto, 1=Manual*
6151	RW	Alarm reset mode	UINT16	0= Auto*, 1=Manual
6152	RW	Long start protection config	UINT16	0=Off*, 1=Trip, 1=Alarm, 3=Trip+Alarm
6153	RW	Long Start protection delay	UINT16	10-9999 (x0.01s), 3000*
6154	RW	Long start supplementary output	BITMAP	0x0000 to 0x0007 (see note 1), 0x0000*
6155	RW	Thermal overload protection config	UINT16	0=Off, 1=Trip, 1=Alarm, 3=Trip+Alarm*
6156	RW	Thermal overload I_{ov}^2	UINT16	100-1000 (x0.01le), 100*
6157	RW	Thermal overload Tc^2	UINT16	10-9999 (x0.01s), 650*
6158	RW	Thermal overload cooling method ³	UINT16	0=Instant, 1=Delay*
6159	RW	Thermal Alert threshold	UINT16	0-99 (%), 60* (0 means disabled)
6160	RW	Thermal overload return threshold ³	UINT16	0-100 (%), 60*
6161	RW	Thermal overload reset mode	UINT16	0= Auto, 1=Manual*
6162	RW	Thermal overload supplementary output	BITMAP	0x0000 to 0x0007 (see note 1), 0x0000*
6163	RW	Jam protection config	UINT16	0=Off*, 1=Trip, 1=Alarm, 3=Trip+Alarm
6164	RW	Jam protection pickup	UINT16	100-1000 (x0.01le), 350*
6165	RW	Jam protection delay	UINT16	10-9999 (x0.01s), 400*
6166	RW	Jam protection supplementary output	BITMAP	0x0000 to 0x0007 (see note 1), 0x0000*
6167	RW	Ground fault protection config	UINT16	0=Off, 1=Trip, 1=Alarm, 3=Trip+Alarm*
6168	RW	Ground fault 3I0 pickup	UINT16	10-1000 (x0.01le), 100*
6169	RW	Ground fault run delay	UINT16	0-9999 (x0.01s), 10*
6170	RW	Ground fault start delay	UINT16	0-9999 (x0.01s), 50*
6171	RW	Ground fault supplementary output	BITMAP	0x0000 to 0x0007 (see note 1), 0x0000*
6172	RW	MTA failure alarm config	UINT16	0=Off*, 1=On
6173	--	Reserved	--	
6174	RW	MTA failure alarm delay	UINT16	10-9999 (x0.01s), 50*
6175	RW	MTA failure alarm supplementary output	BITMAP	0x0000 to 0x0007 (see note 1), 0x0000*
6176	RW	Phase current loss protection config	UINT16	0=Off, 1=Trip, 1=Alarm, 3=Trip+Alarm*
6177	RW	Phase current loss protection delay	UINT16	10-9999 (x0.01s), 250*
6178	RW	Phase current loss block MTA failure	UINT16	0=No*, 1=Yes
6179	RW	Phase current loss supplementary output	BITMAP	0x0000 to 0x0007 (see note 1), 0x0000*
6180	RW	Imbalance protection config	UINT16	0=Off*, 1=Trip, 1=Alarm, 3=Trip+Alarm
6181	RW	Imbalance protection pickup	UINT16	10-100 (%), 30*
6182	RW	Imbalance protection delay	UINT16	10-9999 (x0.01s), 500*
6183	RW	Imbalance protection block MTA failure	UINT16	0=No*, 1=Yes
6184	RW	Imbalance protection supplementary output	BITMAP	0x0000 to 0x0007 (see note 1), 0x0000*
6185	RW	Under power protection config	UINT16	0=Off*, 1=Trip, 1=Alarm, 3=Trip+Alarm
6186	RW	Under power protection pickup	UINT16	-9999-9999 (x0.1kW), 350*
6187	RW	Undervoltage Threshold for blocking under power protection	UINT16	30-95 (x0.01Ue), 60*
6188	RW	Under power protection delay	UINT16	50-9999 (x0.01s), 500*
6189	RW	Under power protection reset delay	UINT16	0-60000 (x0.1s), 0* (0 means disabled)
6190	RW	Under power protection supplementary output	BITMAP	0x0000 to 0x0007 (see note 1), 0x0000*
6191	RW	Short circuit config	UINT16	0=Off, 1=Trip, 1=Alarm, 3=Trip+Alarm*
6192	RW	Short circuit pickup	UINT16	100-1000 (x0.01le), 750*
6193	RW	Short circuit delay	UINT16	0-9999 (x0.01s), 0*
6194	RW	Short circuit start multiple	UINT16	100-200 (x0.01), 100*
6195	RW	Short circuit supplementary output	BITMAP	0x0000 to 0x0007 (see note 1), 0x0000*
6196	RW	Undervoltage protection config	UINT16	0=Off*, 1=Trip, 1=Alarm, 3=Trip+Alarm
6197	RW	Undervoltage protection pickup	UINT16	30-95 (x0.01Ue), 45*

6198	RW	Undervoltage protection delay	UINT16	10-9999 (x0.01s), 900*
6199	RW	Undervoltage No_I Lock	UINT16	0=Disabled, 1=Enabled*
6200	RW	Undervoltage protection reset delay	UINT16	0-60000 (x0.1s), 0* (0 means disabled)
6201	RW	Undervoltage protection supplementary output	BITMAP	0x0000 to 0x0007 (see note 1), 0x0000*
6202	RW	Overvoltage protection config	UINT16	0=Off*, 1=Trip, 1=Alarm, 3=Trip+Alarm
6203	RW	Overvoltage protection pickup	UINT16	105-160 (x0.01Ue), 120*
6204	RW	Overvoltage protection delay	UINT16	10-9999 (x0.01s), 400*
6205	RW	Overvoltage protection supplementary output	BITMAP	0x0000 to 0x0007 (see note 1), 0x0000*
6206	RW	Underload protection config	UINT16	0=Off*, 1=Trip, 1=Alarm, 3=Trip+Alarm
6207	RW	Underload protection pickup	UINT16	10-100 (x0.01Ie), 40*
6208	RW	Underload protection delay	UINT16	1-9999 s, 20*
6209	RW	Underload protection reset delay	UINT16	0-60000 (x0.1s), 0* (0 means disabled)
6210	RW	Underload protection supplementary output	BITMAP	0x0000 to 0x0007 (see note 1), 0x0000*
6211	RW	tE protection config	UINT16	0=Off*, 1=Trip, 1=Alarm, 3=Trip+Alarm
6212	RW	tE protection Tp ³	UINT16	10-9999 (x0.01s), 600*
6213	RW	tE protection supplementary output	BITMAP	0x0000 to 0x0007 (see note 1), 0x0000*
6214	RW	Overload protection config	UINT16	0=Off*, 1=Trip, 1=Alarm, 3=Trip+Alarm
6215	RW	Overload protection pickup	UINT16	100-1000 (x0.01Ie), 120*
6216	RW	Overload protection delay	UINT16	10-9999 (x0.01s), 3000*
6217	RW	Overload protection supplementary output	BITMAP	0x0000 to 0x0007 (see note 1), 0x0000*
6218	RW	Interlock protection config	UINT16	0=Off*, 1=Trip, 1=Alarm, 3=Trip+Alarm
6219	RW	Interlock protection delay	UINT16	0-9999 (x0.01s), 20*
6220	RW	Interlock protection supplementary output	BITMAP	0x0000 to 0x0007 (see note 1), 0x0000*
6221	RW	Thermo protection config	UINT16	0=Off*, 1=Trip, 1=Alarm, 3=Trip+Alarm
6222	RW	Thermo sensor type	UINT16	0=PTC*, 1=NTC, 2=Combined
6223	RW	Thermo protection upper limit	UINT16	10-3000 (x0.01kΩ), 1000*
6224	RW	Thermo protection lower limit	UINT16	10-3000 (x0.01kΩ), 800*
6225	RW	Thermo protection delay	UINT16	10-9999 (x0.01s), 200*
6226	RW	Thermo short cct. alarm	UINT16	0=Off*, 1=On
6227	RW	Thermo open cct. alarm	UINT16	0=Off*, 1=On
6228	RW	Thermo protection supplementary output	BITMAP	0x0000 to 0x0007 (see note 1), 0x0000*
6229	RW	LOP alarm config	UINT16	0=Off, 1=On*
6230	RW	LOP supplementary output	BITMAP	0x0000 to 0x0007 (see note 1), 0x0000*
6231	RW	Phase reversal config	UINT16	0=Off*, 1=Trip, 1=Alarm, 3=Trip+Alarm
6232	RW	Phase reversal supplementary output	BITMAP	0x0000 to 0x0007 (see note 1), 0x0000*
6233	RW	Closed-loop Abnormal protection config	UINT16	0=Off*, 1=Trip, 1=Alarm, 3=Trip+Alarm
6234	RW	Closed-loop Abnormal protection delay	UINT16	10-9999 (x0.01s), 100*
6235	RW	Closed-loop Abnormal protection supplementary output	BITMAP	0x0000 to 0x0007 (see note 1), 0x0000*
6236	RW	Contact protection config	UINT16	0=Off*, 1=On
6237	RW	Contact protection pickup (breaking capacity)	UINT16	400-2000 (x0.01Ie), 800*
6238	RW	Contact failure protection config	UINT16	0=Off*, 1=On
6239	RW	Contact failure protection pickup	UINT16	10-500 (x0.01Ie), 30*
6240	RW	Contact failure protection delay	UINT16	10-9999 (x0.01s), 50*
6241	RW	Contact failure protection stop trigger	UINT16	0=Off, 1=On*
6242	RW	Contact failure protection supplementary output	BITMAP	0x0000 to 0x0007 (see note 1), 0x0000*
6243	RW	ACB trip contactor protection	UINT16	0=Off*, 1=On
6244	RW	ACB trip contactor protection delay	UINT16	10-9999 (x0.01s), 100*
6245	RW	ACB Trip contactor protection supplementary output	BITMAP	0x0000 to 0x0007 (see note 1), 0x0000*
6246	RW	Contact abnormal protection config	UINT16	0=Off*, 1=Trip, 1=Alarm, 3=Trip+Alarm
6247	RW	Contact abnormal protection delay	UINT16	10-9999 (x0.01s), 500*
6248	RW	Contact abnormal protection supplementary output	BITMAP	0x0000 to 0x0007 (see note 1), 0x0000*
6249	RW	Emergency stop alarm config	UINT16	0=Off, 1=On*
6250	RW	Emergency stop alarm supplementary output	BITMAP	0x0000 to 0x0007 (see note 1), 0x0000*
6251	RW	Residual current level I protection config	UINT16	0=Off*, 1=Trip, 1=Alarm, 3=Trip+Alarm
6252	RW	Residual current level I protection pickup	UINT16	200-50000 (x0.1mA), 3000*

6253	RW	Residual current level I protection delay	UINT16	0-9999 (x0.01s), 500*
6254	RW	Residual current level I protection start multiple	UINT16	100-200 (x0.01), 100*
6255	RW	Residual current level I protection supplementary output	BITMAP	0x0000 to 0x0007 (see note 1), 0x0000*
6256	RW	Residual current level II protection config	UINT16	0=Off*, 1=Trip, 1=Alarm, 3=Trip+Alarm
6257	RW	Residual current level II protection pickup	UINT16	200-50000 (x0.1mA), 5000*
6258	RW	Residual current level I protection delay	UINT16	0-9999 (x0.01s), 200*
6259	RW	Residual current level I protection start multiple	UINT16	100-200 (x0.01), 100*
6260	RW	Residual current level I protection supplementary output	BITMAP	0x0000 to 0x0007 (see note 1), 0x0000*
6261	RW	Negative sequence protection config	UINT16	0=Off*, 1=Trip, 1=Alarm, 3=Trip+Alarm
6262	RW	Negative sequence protection pickup	UINT16	10-1000 (x0.01le), 120*
6263	RW	Negative sequence protection run delay	UINT16	0-9999 (x0.01s), 200*
6264	RW	Negative sequence protection start delay	UINT16	0-9999 (x0.01s), 400*
6265	RW	Negative sequence protection supplementary output	BITMAP	0x0000 to 0x0007 (see note 1), 0x0000*
6266	RW	Time for block when start (when motor start)	UINT16	0-9999 (x0.01), 1000* (0 means disabled)
6267	RW	Block when start	BITMAP	See Note 5, 0*
6268	RW	TC1 level I protection config	UINT16	0=Off*, 1=Trip, 1=Alarm, 3=Trip+Alarm
6269	RW	TC1 level I protection pickup	UINT16	200-1500 (x0.1°C), 700*
6270	RW	TC1 level I protection delay	UINT16	0-9999 (x0.01s), 200*
6271	RW	TC1 level I protection supplementary output	BITMAP	0x0000 to 0x0007 (see note 1), 0x0000*
6272	RW	TC1 level II protection config	UINT16	0=Off*, 1=Trip, 1=Alarm, 3=Trip+Alarm
6273	RW	TC1 level II protection pickup	UINT16	200-1500 (x0.1°C), 1000*
6274	RW	TC1 level II protection delay	UINT16	0-9999 (x0.01s), 200*
6275	RW	TC1 level II protection supplementary output	BITMAP	0x0000 to 0x0007 (see note 1), 0x0000*
...	RW	...	BITMAP	0x0000 to 0x0007 (see note 1), 0x0000*
6308	RW	TC6 level I protection config	UINT16	0=Off*, 1=Trip, 1=Alarm, 3=Trip+Alarm
6309	RW	TC6 level I protection pickup	UINT16	200-1500 (x0.1°C), 700*
6310	RW	TC6 level I protection delay	UINT16	0-9999 (x0.01s), 200*
6311	RW	TC6 level I protection supplementary output	BITMAP	0x0000 to 0x0007 (see note 1), 0x0000*
6312	RW	TC6 level II protection config	UINT16	0=Off*, 1=Trip, 1=Alarm, 3=Trip+Alarm
6313	RW	TC6 level II protection pickup	UINT16	200-1500 (x0.1°C), 1000*
6314	RW	TC6 level II protection delay	UINT16	0-9999 (x0.01s), 200*
6315	RW	TC6 level II protection supplementary output	BITMAP	0x0000 to 0x0007 (see note 1), 0x0000*
6316	RW	Insulation resistance protection config	UINT16	0=Off*, 1=Trip, 1=Alarm, 3=Trip+Alarm
6317	RW	Insulation resistance protection pickup	UINT16	1-500 (x0.1MΩ), 10*
6318	RW	Insulation resistance protection supplementary output	BITMAP	0x0000 to 0x0007 (see note 1), 0x0000*

Table 5-13 Protection Setting

Notes:

1. The bit value of Bit0 to Bit2 for supplementary output register represent the status of R1 to R3 supplementary outputs, where “1” means configured, and “0” means not configured.
2. Please refer to **Section 4.4.4.5** to set a proper Tc and Iov for the Thermal Model based on the motor nameplate information.
3. The **Thermal overload return threshold** is valid only when **Thermal overload cooling method** (register **6158**) is set to **Delay**.
4. Please refer to **Section 4.4.4.6** to set a proper Tp value for tE Time protection based on the motor nameplate information.
5. The following table illustrates all the protection options for Block When Start with a bit value of “1” meaning Block and “0” meaning Unblock.

BIT	Protection	BIT	Protection	BIT	Protection	BIT	Protection
Bit0	Thermal Overload	Bit4	Imbalance	Bit8	tE Time	Bit12	Residual Current level I
Bit1	Jam	Bit5	Under Power	Bit9	Overload	Bit13	Residual Current level II
Bit2	Ground Fault	Bit6	Short Circuit	Bit10	Interlock	Bit14	Negative Sequence
Bit3	Phase Current Loss	Bit7	Underload	Bit11	Phase Reversal		

Table 5-14 Protection options for Block When Start

5.7.4 Control Setting

Register	Property	Description	Format	Range/option, default*	
6350	RW	Starter function	UINT16	0=Direct-on-line*, 1=Reduce-voltage start, 2=FWD-REV, 3=2-speed 4=Inverter Coordinated Control 5=High-power Motor Auxiliary Control 6=Circuit Breaker Control 7=Motorized Value Control	
6351	RW	Undervoltage restart config	UINT16	0=Off*, 1=On	
6352	RW	Quick start time ¹	UINT16	0-999 (x0.01s), 250* (0 means disabled)	
6353	RW	Undervoltage restart preset DO close	UINT16	0=OFF, 1=ON*	
6354	RW	Undervoltage restart delay ¹	UINT16	1-9999 (x0.1s), 2*	
6355	RW	Allowed time ¹	UINT16	5-9999 (x0.1s), 200*	
6356	RW	Dip threshold	UINT16	30-95 (x0.01Ue), 75*	
6357	RW	Recover voltage	UINT16	80-160 (x0.01Ue), 85*	
6358	RW	Undervoltage restart auxiliary DO	UINT16	0=N/A*, 1-6: DO1-DO6	
6359	RW	Undervoltage restart auxiliary DO delay	UINT16	0-9999 (x0.01s), 0*	
6360	RW	DO motor running pulse width	UINT16	0-3000 (x0.01s), 10*	
6361	RW	Block Time	UINT16	0-9999 (x0.1s), 0*	
6362	RW	Device autorestart config	UINT16	0=Off*, 1=On	
6363	RW	Device autorestart mode	UINT16	0=Restart, 1=Recover*	
6364	RW	Device autorestart delay	UINT16	10-9999 (x0.01s), 10*	
6365	RW	Motor autorestart config	UINT16	0=Off*, 1=On	
6366	RW	Motor autorestart mode	UINT16	0=Restart, 1=Recover*	
6367	RW	Motor autorestart delay	UINT16	10-9999 (x0.01s), 250*	
6368	RW	Reduce-voltage start mode	UINT16	0=BBM (break-before-make)*, 1=MBB (make-before-break)	
6369	RW	Reduce-voltage start delay	UINT16	100-9999 (x0.01s), 2500*	
6370	RW	Reduce-voltage lset	UINT16	0-300 (x0.01Ie), 0 (0 means disabled)	
6371	RW	2-Speed I1 (Inominal for speed 1)	UINT16	20-500 (x0.01Ie), 100*	
6372	RW	2-Speed I2 (Inominal for speed 2)	UINT16	20-500 (x0.01Ie), 50*	
6373	RW	2-Speed minimum switching delay	UINT16	100-9999 (x0.01s), 500*	
6374	RW	FWD-REV minimum switching delay	UINT16	100-9999 (x0.01s), 500*	
6375	RW	Inverter Coordinated Control start delay	UINT16	100-9999 (x0.01s), 500*	
6376	RW	High-power Motor Auxiliary Control start delay	UINT16	100-9999 (x0.01s), 1000*	
6377	RW	Start control - start block time	UINT16	0-9999 (s), 0* (0 means disabled)	
6378	RW	Start control - stop block time	UINT16	0-9999 (s), 0* (0 means disabled)	
6379	RW	Start control - max. start count	UINT16	0-20, 0* (0 means disabled)	
6380	RW	Start control - interval	UINT16	1-9999 (min), 30*	
6381	RW	Stop DI trigger trip output mode	UINT16	0=Latched*, 1=Pulse	
6382	RW	CMD mode	UINT16	0=Edge Trigger*, 1=Level Trigger	
6383	RW	DP control config	UINT16	0=Off*, 1=On	
6384	RW	DP control delay	UINT16	1-9999 (x0.1s), 50*	
6385	RW	Motorized Value Control	Control Timeout	UINT16	0-60000 (x0.1s), 200*
6386	RW		Start Timeout	UINT16	0-60000 (x0.1s), 80*
6387	RW		DI Emergency	UINT16	0=Off*, 1=On

Table 5-15 Protection and Control Setting

Notes:

1. The **Allowed Time** shall be longer than the accumulation of **Quick Start Time** and **Auto-start Delay**.

5.7.5 DI Setting

Register	Property	Description	Format	Range/Options, Default*
6500	RW	DI1 Mode	UINT16	0~28 (See Note 2), 0
6501	RW	DI1 Type	UINT16	0=NO* (Normally Open), 1=NC (Normally Closed)
6502	RW	DI1 Debounce Time	UINT16	20~9999 (ms), 40*
6503	RW	DI1 Excitation Source	UINT16	0=DC*, 1=AC, 2=External

...	RW	...	UINT16	
6544	RW	DI12 Mode	UINT16	0~28 (See Note2), 0
6545	RW	DI12 Type	UINT16	0=NO* (Normally Open), 1=NC (Normally Closed)
6546	RW	DI12 Debounce Time	UINT16	20~9999 (ms), 40*
6547	RW	DI12 Excitation Source	UINT16	0=DC*, 1=AC, 2=External

Table 5-16 DI Setting

Notes:

- The DI11 and DI12 are valid only when the PMC-KT module is equipped and enabled. It is recommended to configure the DI11 and DI12 with Common State, QF State, Reset Protection and Position function mode.
- The following table illustrates the options for DI Mode. For Local/Remote control switch, KMA State, KMB State and QF State, only one DI can be configured with the same function.

Value	Option	Value	Option	Value	Option	Value	Option
0	Common State	8	Local Start B	16	Remote FWD	24	Position
1	Local/Remote	9	KMA State	17	Remote REV	25	Open Limit Signal
2	Interlock	10	KMB State	18	Emergency Start A	26	Close Limit Signal
3	Stop	11	QF State	19	Emergency Start B	27	Open Over Torque
4	Emergency Stop	12	Start Block	20	Local FWD	28	Close Over Torque
5	Remote Start A	13	Remote Stop	21	Local REV		
6	Remote Start B	14	Local Stop	22	FWD		
7	Local Start A	15	Reset Protection	23	REV		

Table 5-17 DI Mode Options

- Set the **DIx Excitation Source** to **External** if the DI is energized with the PMC-KI Converter.

5.7.6 DO Setting

Register	Property	Description	Format	Range/Options, Default*
6600	RW	DO1 Mode	UINT16	0~11 (See Note 2), 1* (Trip Contactor)
6601	RW	DO1 Pulse Width	UINT16	1~9999 (x0.01s), 100* (0 means Latch mode)
6602	RW	DO2 Mode	UINT16	0~11 (See Note 2), 2* (Self-check)
6603	RW	DO2 Pulse Width	UINT16	1~9999 (x0.01s), 100* (0 means Latch mode)
6604	RW	DO3 Mode	UINT16	0~11 (See Note 2), 3* (Start A)
6605	RW	DO3 Pulse Width	UINT16	1~9999 (x0.01s), 100* (0 means Latch mode)
6606	RW	DO4 Mode	UINT16	0~11 (See Note 2), 6* (Trip Air Circuit Breaker)
6607	RW	DO4 Pulse Width	UINT16	1~9999 (x0.01s), 100* (0 means Latch mode)
6608	RW	DO5 Mode	UINT16	0~11 (See Note 2), 5* (Alarm)
6609	RW	DO5 Pulse Width	UINT16	1~9999 (x0.01s), 100* (0 means Latch mode)
6610	RW	DO6 Mode	UINT16	0~11 (See Note 2), 0* (Spare)
6611	RW	DO6 Pulse Width	UINT16	1~9999 (x0.01s), 100* (0 means Latch mode)

Table 5-18 DO Setting

Notes:

- The DO6 is valid only when the PMC-KT module is equipped and enabled.
- The following table illustrates the options for DO Mode.

Value	Option	Value	Option	Value	Option	Value	Option
0	Spare	3	Start A	6	Trip Air Circuit Breaker	9	R2
1	Trip Contactor	4	Start B	7	Trip Cooler/S-Motor	10	R3
2	Self-check	5	Alarm	8	R1	11	Motor Running

Table 5-19 DO Mode Options

5.7.7 AO Setting

Register	Property	Parameter	Format	Range/Options, Default*
6650	RW	AO parameter	UINT16	0=Ia (A), 1=Ib (A), 2=Ic (A), 3=P (kW), 4=IR (mA), 5=I0 (A), 6=Iavg, 7=Ullavg, 8=VARA1
6651	RW	Zero scale	INT32	-999,999 to 999,999, 40*
6653	RW	Full scale	INT32	-999,999 to 999,999, 200*
6655	RW	AO hold time	UINT16	0-50 (x0.1s), 0* (0 means that the relay will stop the analog output signal immediately if power is lost)

Table 5-20 AO Setting

5.7.8 Insulation Test Setting

Register	Property	Parameter	Format	Range/Options, Default*
6680	RW	Insulation test config	UINT16	0=Off*, 1=Manual, 2=Auto
6681	RW	Interval	UINT16	1-30000 (x0.1h), 10*

Table 5-21 Insulation Test Setting

Notes:

- The Interval setting is only valid when the Insulation test config is set to **Auto**.

5.7.9 Programmable Logic Setting

5.7.9.1 Programmable Logic Event Description

Register	Property	Description	Format	Notes
8000-8006	RW	Programmable logic trip event 1 description	CHAR	Less than 14 characters
8007-8013	RW	Programmable logic trip event 2 description	CHAR	Less than 14 characters
8014-8020	RW	Programmable logic trip event 3 description	CHAR	Less than 14 characters
8021-8027	RW	Programmable logic alarm event 1 description	CHAR	Less than 14 characters
8028-8034	RW	Programmable logic alarm event 2 description	CHAR	Less than 14 characters
8035-8041	RW	Programmable logic alarm event 3 description	CHAR	Less than 14 characters
8042-8048	RW	Programmable logic trip ACB event 1 description	CHAR	Less than 14 characters
8049-8055	RW	Programmable logic trip ACB event 2 description	CHAR	Less than 14 characters
8056-8062	RW	Programmable logic trip ACB event 3 description	CHAR	Less than 14 characters
8063-8069	RW	Programmable logic event 1 description	CHAR	Less than 14 characters
8070-8076	RW	Programmable logic event 2 description	CHAR	Less than 14 characters
8077-8083	RW	Programmable logic event 3 description	CHAR	Less than 14 characters

Table 5-22 Programmable Logic Event Description

5.7.9.2 Programmable Logic Configurable Variable

Register	Property	Description	Format	Range, Default*
8100	RW	mbCtrlD1	UINT32	0~0xFFFFFFFF, 0*
8102	RW	mbCtrlD2	UINT32	0~0xFFFFFFFF, 0*
8104	RW	mbCtrlD3	UINT32	0~0xFFFFFFFF, 0*
8106	RW	mbCtrlD4	UINT32	0~0xFFFFFFFF, 0*

Table 5-23 Programmable Logic Configurable Variable

5.7.9.3 Programmable Logic Control Command

Register	Property	Description	Format	Range/Option
8200	WO	mbCtrlC1	UINT16	0xFF00/0x0000
8201	WO	mbCtrlC2	UINT16	0xFF00/0x0000
8202	WO	mbCtrlC3	UINT16	0xFF00/0x0000
8203	WO	mbCtrlC4	UINT16	0xFF00/0x0000
8204	WO	mbCtrlC5	UINT16	0xFF00/0x0000
8205	WO	mbCtrlC6	UINT16	0xFF00/0x0000
8206	WO	mbCtrlC7	UINT16	0xFF00/0x0000
8207	WO	mbCtrlC8	UINT16	0xFF00/0x0000

Table 5-24 Programmable Logic Control Command

5.8 Data Logging

5.8.1 Protection Log

The **Protection log pointer** (register 0000) points to the location within the **Protection Log** where the next event will be stored. The following formula is used to determine the register address of the most recent protection event referred by **Protection log pointer** value: Register Address = 10000 + Modulo [**Protection log pointer**-1] / 64] *22.

Register	Property	Description	Format
10000-10021	RO	Event 1	See Table 5-26
10022-10043	RO	Event 2	
10044-10065	RO	Event 3	
...	RO	...	
11386~11407	RO	Event 64	

Table 5-25 Protection Logs

Note:

1. Protection log data structure.

Offset	Properties	Description	Format	Note
+0	RO	High-order Byte: Event Classification	UINT16	See Appendix A
		Low-order Byte: Sub-Classification		See Appendix A
+1	RO	High-order Byte: Year	Timestamp	0-99 (Year-2000)
		Low-order Byte: Month		1 to 12
+2	RO	High-order Byte: Day		1 to 31
		Low-order Byte: Hour		0 to 23
+3	RO	High-order Byte: Minute		0 to 59
		Low-order Byte: Second	0 to 59	
+4	RO	Millisecond		0 to 999
+5	RO	High-order Byte: Protection Level: 0=Normal, 1=Alarm, 2=Trip	UINT16	
		Low-order Byte: Status (1/2)		
+6~+19	RO	Event Value		See Appendix A

+20	RO	High-order Byte: Protection Type Low-order Byte: Error Code	See Table 5-27
+21	RO	Reserved	

Table 5-26 Protection log data structure

Protection Type	Error Code	Description
1=Phase Current Loss	1	Loss of IA
	2	Loss of IB
	3	Loss of IC
3=Ground Fault	1	Phase A Ground Fault
	2	Phase B Ground Fault
	3	Phase C Ground Fault
	4	Phase AB Ground Fault
	5	Phase BC Ground Fault
	6	Phase CA Ground Fault
	7	Phase ABC Ground Fault
4=LOP	1	Loss of UA
	2	Loss of UB
	3	Loss of UC
	4	Loss of UAB
	5	Loss of UBC
	6	Loss of UCA
	7	ABC Phase Loss
5=Short Circuit	1	Phase A Ground Fault
	2	Phase B Ground Fault
	3	Phase C Ground Fault
	4	Phase AB Ground Fault
	5	Phase BC Ground Fault
	6	Phase CA Ground Fault
	7	Phase ABC Ground Fault
	8	Phase AB P-P Short
	9	Phase BC P-P Short
	10	Phase CA P-P Short
	11	Phase ABC Short Circuit
8=Phase Reversal	1	Voltage Phase Sequence Error
	2	Current Phase Sequence Error
	3	Voltage/Current Phase Sequence Error

Table 5-27 Protection Diagnostic Code

5.8.2 SOE Log

The **SOE log pointer** (register 0002) points to the location within the **SOE Log** where the next event will be stored. The following formula is used to determine the register address of the most recent event referred by **SOE log pointer** value: Register Address = 13000 + Modulo [SOE log pointer-1] / 64] * 8.

Register	Property	Description	Format
13000~13007	RO	Event 1	See Table 5-29
13008~13015	RO	Event 2	
13016~13023	RO	Event 3	
...	RO	...	
13504~13511	RO	Event 64	

Table 5-28 SOE Log

Note:

- SOE log data structure.

Offset	Properties	Description	Format	Note
+0	RO	High-order Byte: Event Classification	UINT16	See Appendix A
		Low-order Byte: Sub-Classification		See Appendix A
+1	RO	High-order Byte: Year	Timestamp	0-99 (Year-2000)
		Low-order Byte: Month		1 to 12
+2	RO	High-order Byte: Day		1 to 31
		Low-order Byte: Hour		0 to 23
+3	RO	High-order Byte: Minute		0 to 59
		Low-order Byte: Second	0 to 59	
+4	RO	Millisecond		0 to 999
+5	RO	High-order Byte: Protection Level (0=Normal, 1=Alarm, 2=Trip)	UINT16	
	RO	Low-order Byte: DI/DO Operation (1=Open, 2=Close)		
+6~+7	RO	Event Value		See Appendix A

Table 5-29 SOE Log Data Structure

5.8.3 Start Report

The **Start pointer** (register 0004) points to the location within the **Start Report** where the next report will be stored. The following formula is used to determine the register address of the most recent Start Report referred by **Start Report pointer** value: Register Address = 15000 + Modulo [**Start Report pointer**-1] / 64] * 12.

Register	Property	Description	Format
15000~15011	RO	Report 1	See Table 5-31
15012~12023	RO	Report 2	
15024~15035	RO	Report 3	
...	RO	...	
15756~15767	RO	Report 64	

Table 5-30 Start Report

Note:

1. Start Report data structure.

Offset	Properties	Description	Format	Note
+0	RO	High-order Byte: Event Classification (6=Start)	UINT16	--
		Low-order Byte: Trigger Source		See Table 5-32
+1	RO	High-order Byte: Year	Timestamp	0-99 (Year-2000)
		Low-order Byte: Month		1 to 12
+2	RO	High-order Byte: Day		1 to 31
		Low-order Byte: Hour		0 to 23
+3	RO	High-order Byte: Minute		0 to 59
		Low-order Byte: Second		0 to 59
+4	RO	Millisecond	0 to 999	
+5	RO	High-order Byte: Reserved	UINT16	--
		Low-order Byte: motor status after start (0=stop, 1=start, 2=running, 3=FWD, 4=REV, 5=Speed 1, 6=Speed 2)		
+6	RO	Maximum starting current (x0.001A)	UINT32	
+8	RO	Motor start time (x0.01s)	UINT32	
+10	RO	Minimum starting voltage (x0.01V)	UINT32	

Table 5-31 Start Report Data Structure

2. The following table illustrates all the motor start trigger source.

Value	Control Source	Value	Control Source	Value	Control Source	Value	Control Source
1	DI1 Control	7	DI7 Control	17	HMI Control	23	External Source
2	DI2 Control	8	DI8 Control	18	Modbus Control	24	Quick Start
3	DI3 Control	9	DI9 Control	19	Profibus Control	25	Profinet Remote Control
4	DI4 Control	10	DI10 Control	20	PL Control		
5	DI5 Control	11	DI11 Control	21	Undervoltage Restart		
6	DI6 Control	12	DI12 Control	22	AutoRestart		

Table 5-32 Start Trigger Source

5.8.4 Stop Report

The **Stop pointer** (register 0006) points to the location within the **Stop Report** where the next report will be stored. The following formula is used to determine the register address of the most recent Stop Report referred by **Stop Report pointer** value: Register Address = 18000 + Modulo [**Stop Report pointer**-1] / 64] * 12.

Register	Property	Description	Format
18000~18011	RO	Report 1	See Table 5-34
18012~18023	RO	Report 2	
18024~18035	RO	Report 3	
...	RO	...	
18756~18767	RO	Report 64	

Table 5-33 Stop Report

Notes:

1. Stop Report data structure.

Offset	Properties	Description	Format	Note
+0	RO	High-order Byte: Event Classification (7=Stop)	UINT16	
		Low-order Byte: Trigger Source		See Table 5-35
+1	RO	High-order Byte: Year	Timestamp	0-99 (Year-2000)
		Low-order Byte: Month		1 to 12
+2	RO	High-order Byte: Day		1 to 31
		Low-order Byte: Hour		0 to 23
+3	RO	High-order Byte: Minute		0 to 59
		Low-order Byte: Second		0 to 59
+4	RO	Millisecond	0 to 999	
+5	RO	Reserved	--	--

+6	RO	IA (x0.001A)	UINT32	
+8	RO	IB (x0.001A)	UINT32	
+10	RO	IC (x0.001A)	UINT32	

Table 5-34 Stop Report Data Structure

2. The following table illustrates all the motor stop trigger source.

Value	Control Source	Value	Control Source	Value	Control Source	Value	Control Source
1	DI1 Control	8	DI8 Control	19	Profibus Control	26	Change Speed
2	DI2 Control	9	DI9 Control	20	PL Control	27	Start Block
3	DI3 Control	10	DI10 Control	21	External Source	28	Protection Trip
4	DI4 Control	11	DI11 Control	22	Voltage Interruption	29	Motorized Valve Control
5	DI5 Control	12	DI12 Control	23	DP Comm. Interrupt	30	Profinet Control
6	DI6 Control	17	HMI Control	24	Control Para. Update		
7	DI7 Control	18	Modbus Control	25	Switch Direction		

Table 5-35 Stop Trigger Source

5.8.5 Insulation Log

The relay can store up to 500 entries insulation test log. Retrieve the newest insulation logs through writing the entry number which you can get from **Insulation log pointer (register 0012)** into **Insulation log index (register 21000)**. For example, if the value for **Insulation log pointer** is 10500, then you can write 10500 to 10001 into 21000 register where 10500 means the newest logs and 10001 means the oldest logs.

Register	Property	Description	Format	Note
21000	RW	Insulation log Index	UINT32	
21002	RO	High-order Byte: Event Classification	UINT16	8=insulation log
		Low-order Byte: Trigger Source		1=auto, 2=manual
21003	RO	High-order Byte: Year	Timestamp	0-99 (Year-2000)
		Low-order Byte: Month		1 to 12
21004	RO	High-order Byte: Day		1 to 31
		Low-order Byte: Hour		0 to 23
21005	RO	High-order Byte: Minute		0 to 59
		Low-order Byte: Second		0 to 59
21006	RO	Millisecond		0 to 999
21007	RO	Reserved	--	
21008	RO	High-order Byte: test result	UINT16	1-successful, 2=fail
		Low-order Byte: fail reason	UINT16	see note 1
21009	RO	Insulation Resistance (x0.01kΩ)	UINT16	

Table 5-36 Insulation Log Structure

Notes:

1. The following table illustrates the possible fail reasons for an insulation test fail event.

Value	Reason	Value	Reason
1	Communication to the PMC-KR is fail.	7	Motor is starting
2	Hazardous voltage (>30V) on the test lead is detected.	8	Motor is running
3	Insulation resistance calculation is over time	9	Motor is in undervoltage restarting
4	Manual stop	10	Motor is in motor auto restarting
5	Communication is interrupted	11	Motor is in device auto restarting
6	Start command is received	12	Motor will stop

Table 5-37 Reason Code for Insulation Test Fail

5.8.6 Waveform Log

The relay can store up to 16 entries waveform log. Retrieve the newest waveform logs through writing the entry number which you can get from **Waveform log pointer (register 0010)** into **Waveform log index (register 35000)**. For example, if the value for **Waveform log pointer** is 17, then you can write 17 to 2 into 35000 register where 17 means the newest logs and 2 means the oldest logs.

Register	Property	Description	Format	Note/Range	
35000	RW	Waveform log Index	UINT32		
35002-35098	--	Reserved	--		
35100	RO	Start time	Ho: Year	UINT8	0-99 (Year-2000)
			Lo: Month	UINT8	1 to 12
35101	RO	Start time	Ho: Day	UINT8	1 to 31
			Lo: Hour	UINT8	0 to 23
35102	RO	Start time	Ho: Minute	UINT8	0 to 59
			Lo: Second	UINT8	0 to 59
35103	RO	Start time	Millisecond	UINT16	0 to 999
35104	RO	Trigger time	Ho: Year	UINT8	0-99 (Year-2000)
			Lo: Month	UINT8	1 to 12
35105	RO	Trigger time	Ho: Day	UINT8	1 to 31

			Lo: Hour	UINT8	0 to 23
35106	RO	Trigger time	Ho: Minute	UINT8	0 to 59
			Lo: Second	UINT8	0 to 59
			Millisecond	UINT16	0 to 999
35108	RO	Trigger Source	Ho: Event classification	UINT16	See Appendix A
			Lo: Sub-classification		
35109	RO	Ho: Protection Level (0=Normal, 1=Alarm, 2=Trip)		UINT16	
		Lo: DI/DO Operation (1=Open, 2=Close)			
35110	RO	System frequency		UINT16	
35111	RO	Number of samples		UINT16	
35112	RO	Sampling rate for 1 st sample		UINT16	
35113	RO	Stop for 1 st sample		UINT16	
35114-35118	--	Reserved		--	
35119	RW	Recording channel		UINT16	See note 2
35120	RO	Primary value (x0.01A / x0.01V)		INT32	
35122	RO	Secondary value (x0.001A / x0.001V)		INT32	
35124-35129	--	Reserved		--	
35130-36829	RO	RMS value (total 1700 samples)		INT16	

Table 5-38 Waveform Log

Note:

1. The value of registers 35120 to 36829 shall be updated once the value of register 35119 (Recording Channel) has been written.
2. The following table illustrates the channel ID with the corresponding waveform recording channel.

ID	Channel (scale, unit)	ID	Channel (scale, unit)
1	UAB (x0.1V)	5	IB (x0.01A)
2	UBC (x0.1V)	6	IC (x0.01A)
3	UCA (x0.1V)	7	3IO (x0.01A)
4	IA (x0.01A)		

Table 5-39 Recording Channel for Waveform Log

5.9 Remote Control

The Alarm/DO Control registers are implemented as both “Write-Only” Modbus Coil Registers (0XXXXX) and Modbus Holding Registers (4XXXXX), which can be controlled with the Force Single Coil command (Function Code 0x05) or the Preset Multiple Hold Registers (Function Code 0x10). The relay does not support the Read Coils command (Function Code 0x01) because Alarm/DO Control registers are “Write-Only”. The DO Status register 0017 should be read instead to determine the current DO status.

The relay adopts the ARM before EXECUTE operation for the remote control of its Digital Outputs if this function is enabled through the **DO Remote** Setup register (41031), which is disabled by default. Before executing an OPEN or CLOSE command on a Relay Output, it must be “Armed” first. This is achieved by writing the value 0xFF00 to the appropriate register to “Arm” a particular DO operation. The DO will be “Disarmed” automatically if an “Execute” command is not received within 15 seconds after it has been “Armed”. If an “Execute” command is received without first having received an “Arm” command, the meter ignores the “Execute” command and returns the 0x04 exception code.

Register	Property	Description	Format	Note
9100	WO	Arm DO1 Close	UINT16	Writing “0xFF00” to the register to execute the described action.
9101	WO	Execute DO1 Close	UINT16	
9102	WO	Arm DO1 Open	UINT16	
9103	WO	Execute DO1 Open	UINT16	
9104	WO	Arm DO2 Close	UINT16	
9105	WO	Execute DO2 Close	UINT16	
9106	WO	Arm DO2 Open	UINT16	
9107	WO	Execute DO2 Open	UINT16	
9108	WO	Arm DO3 Close	UINT16	
9109	WO	Execute DO3 Close	UINT16	
9110	WO	Arm DO3 Open	UINT16	
9111	WO	Execute DO3 Open	UINT16	
9112	WO	Arm DO4 Close	UINT16	
9113	WO	Execute DO4 Close	UINT16	
9114	WO	Arm DO4 Open	UINT16	
9115	WO	Execute DO4 Open	UINT16	
9116	WO	Arm DO5 Close	UINT16	
9117	WO	Execute DO5 Close	UINT16	
9118	WO	Arm DO5 Open	UINT16	
9119	WO	Execute DO5 Open	UINT16	
9120	WO	Arm DO6 Close	UINT16	
9121	WO	Execute DO6 Close	UINT16	

9122	WO	Arm DO6 Open	UINT16
9123	WO	Execute DO6 Open	UINT16
9124~9139	--	Reserved	--
9140	WO	Arm Protection Reset ¹	UINT16
9141	WO	Execute Protection Reset ¹	UINT16

Table 5-40 DO Control

Note:

- To execute the Protection Reset on the relay, it is required to send an “Arm Protection Reset” request first. And within 15 seconds, the “Execute Protection Reset” request must be received subsequently.

5.10 Manual Operation

Register	Property	Description	Format	Note
9700	WO	Remote start A	UINT16	Writing “0xFF00” to the register to execute the described action.
9701	WO	Remote start B	UINT16	
9702	WO	Remote stop	UINT16	
9703	WO	Clear all logs	UINT16	
9704	WO	Clear energy	UINT16	
9705	WO	Clear statistics	UINT16	
9706	WO	Clear start report	UINT16	
9707	WO	Clear stop report	UINT16	
9708	WO	Clear waveform recorder	UINT16	
9709	--	Reserved	--	
9710	WO	Clear insulation test log	UINT16	
9711	WO	Manual trigger waveform recorder	UINT16	
9712	--	Reserved	--	
9713	WO	Start insulation test	UINT16	
9714	WO	End insulation test	UINT16	

Table 5-41 Manual Operation Registers

5.11 Time Registers

There are two sets of Time registers supported by the relay - Year/Month/Day/Hour/Minute/Second (Registers # 60000 to 60002 for 6-digit addressing and Registers # 9000 to 9002 for 5-digit addressing) and UNIX Time (Registers # 60004 to 60005 for 6-digit addressing and Registers # 9004 to 9005 for 5-digit addressing). When sending time to the relay over Modbus communications, care should be taken to only write one of the two Time register sets. All registers within a Time register set must be written in a single transaction. If registers 60000 to 60004 (or 9000 to 9004 for 5-digit addressing) are being written to at the same time, both Time register sets will be updated to reflect the new time specified in the UNIX Time register set 60004 (9004) where the time specified in registers 60000 to 60003 (9000-9003 for 5-digit addressing) will be ignored. Writing to the Millisecond register 60003 (9003 for 5-digit addressing) is optional during a Time Set operation. When broadcasting time, the function code must be set to 0x10 (Pre-set Multiple Registers). Incorrect date or time values will be rejected by the meter.

Register	Property	Description	Format	Note
60000	9000	RW	High-order Byte: Year	10-90 (Year-2000)
			Low-order Byte: Month	1 to 12
60001	9001	RW	High-order Byte: Day	1 to 31
			Low-order Byte: Hour	0 to 23
60002	9002	RW	High-order Byte: Minute	0 to 59
			Low-order Byte: Second	0 to 59
60003	9003	RW	Millisecond	0 to 999
60004 ~ 60005	9004 ~ 9005	RW	UNIX Time	0x386D4380 to 0xf48656FF The corresponding time is 2000.01.01 00:00:00 to 2037.12.31 23:59:59 (GMT 0:00 Time Zone)

Table 5-42 Time Registers

5.12 Device Information

Register	Property	Description	Format	Note
9800	RO	Meter Model	CHAR	See Note 1
9820	RO	Firmware Version	UINT16	e.g. 10000 shows the version is V1.00.00
9821	RO	Modbus Version	UINT16	e.g. 10 shows the version is V1.0
9822	RO	Firmware Date: Year-2000	UINT16	e.g. 130709 means July 9, 2013
9823	RO	Firmware Date: Month	UINT16	
9824	RO	Firmware Date: Day	UINT16	
9825	RO	Serial Number	UINT32	
9827	RO	Feature Code	BITMAP	Bit0 (System Frequency): 0=50Hz, 1=60Hz Bit1 (Language): 0=Chinese, 1=English Bit2-Bit3(I/O): 0=10DI+5DO, 1=10DI+5DO+AO Other bits are reserved

9828	RO	DP Version	UINT16	e.g. 10 shows the version is V1.0
9829	RO	DP Date: Year-2000	UINT16	e.g. 130709 means July 9, 2013
9830	RO	DP Date: Month	UINT16	
9831	RO	DP Date: Day	UINT16	
9832	RO	Profibus Version	UINT16	e.g. 10 shows the version is V1.0
9833	RO	Programmable Logic Version	UINT16	e.g. 100 shows the version is V1.00

Table 5-43 Device Information

Notes:

- The **Meter Model** appears in registers 60200 to 60219 and contains the ASCII encoding of the string "PMC-550D" as shown in the following table.

Register	Value(Hex)	ANSII
60200	0x50	P
60201	0x4D	M
60202	0x43	C
60203	0x2D	-
60204	0x35	5
60205	0x35	5
60206	0x30	0
60207	0x44	D
60208~60219	0x20	(space)

Appendix A – SOE and Protection Log Classifications

Classification	Sub-Classification	Status	Description	Event Value
1=I/O Change	1	1/2	DI1 open / DI1 close	DIx Function (INT32): 0~24 See Table 5-17 DI Mode Options
	2	1/2	DI2 open / DI2 close	
	3	1/2	DI3 open / DI3 close	
	4	1/2	DI4 open / DI4 close	
	5	1/2	DI5 open / DI5 close	
	6	1/2	DI6 open / DI6 close	
	7	1/2	DI7 open / DI7 close	
	8	1/2	DI8 open / DI8 close	
	9	1/2	DI9 open / DI9 close	
	10	1/2	DI10 open / DI10 close	
	11	1/2	DI11 open / DI11 close	
	12	1/2	DI12 open / DI12 close	
	21	1/2	DO1 return / DO1 act	DOx Function (INT32): 0~11 Table 5-19 DO Mode Options
	22	1/2	DO2 return / DO2 act	
	23	1/2	DO3 return / DO3 act	
	24	1/2	DO4 return / DO4 act	
	25	1/2	DO5 return / DO5 act	
26	1/2	DO6 return / DO6 act		
	40	1/2	PMC-KR module is online/offline	--
	41	1/2	PMC-KT module is online/offline	--
2=Protection Log	1	1/2	Reduce-voltage start succeed/fail	Record Value: +0 (INT32): IA (x0.001A) +2 (INT32): IB (x0.001A) +4 (INT32): IC (x0.001A) +6 (INT32): UAB (x0.01V) +8 (INT32): UBC (x0.01V) +10 (INT32): UCA (x0.01V) +12 (INT32): Reserved
	2	2	FWD-REV start fail	Record Value: +0 (INT32): IA (x0.001A) +2 (INT32): IB (x0.001A) +4 (INT32): IC (x0.001A) +6 (INT32): UAB (x0.01V) +8 (INT32): UBC (x0.01V) +10 (INT32): UCA (x0.01V) +12 (INT32): Reserved
	3	2	2-Speed start fail	Record Value: +0 (INT32): IA (x0.001A) +2 (INT32): IB (x0.001A) +4 (INT32): IC (x0.001A) +6 (INT32): UAB (x0.01V) +8 (INT32): UBC (x0.01V) +10 (INT32): UCA (x0.01V) +12 (INT32): Reserved
	6	1/2	Undervoltage restart succeed/fail	Record Value: +0 (INT32): UAB Start (x0.01V) +2 (INT32): UBC Start (x0.01V) +4 (INT32): UAB End (x0.01V) +6 (INT32): UBC End (x0.01V) +8 (UINT32): Dip Duration (x0.01s) <hr/> +10 (BITMAP): Bit0~Bit11 stands for DI1~DI12 status, Bit16~Bit21 stands for DO1~DO6 status 0 means Open while 1 means Close <hr/> +12 (UINT32): Fail Reason 1=Dip duration exceeds the allowed time 2=Dip duration + restart delay > allowed time 3=No Voltage, 4=DI KMA/KMB Close, 5=Motor le <> 0
	7	1	Quick restart fail	Record Value: +0 (INT32): IA (x0.001A) +2 (INT32): IB (x0.001A) +4 (INT32): IC (x0.001A) +6 (INT32): UAB (x0.01V)
	8	1	Device auto restart	+0 (INT32): IA (x0.001A) +2 (INT32): IB (x0.001A) +4 (INT32): IC (x0.001A) +6 (INT32): UAB (x0.01V)

				+8 (INT32): UBC (x0.01V) +10 (INT32): UCA (x0.01V) +12 (INT32): 3I0 (x0.001A)
9	2	Invalid start command		Record Value: +0 (UINT32): Start Command Type 1=Start A, 2=Start B <hr/> +2 (UINT32): Start trigger source See Table 5-32 Start Trigger Source <hr/> +4 (UINT32): Result 1=Succeed 2=Fail-Permission Mismatch 3=Fail-Motor Started/Running 4=Fail-Start Block 5=Fail-Start Mismatch
10	2	Invalid stop command		Record Value: +0 (UINT32): Stop Command Type 3=Stop <hr/> +2 (UINT32): Stop Command Source See Table 5-35 Stop Trigger Source <hr/> +4 (UINT32): Result 1=Succeed, 2=Fail-Permission Mismatch
11	1	Motor auto restart		Record Value: +0 (INT32): IA (x0.001A) +2 (INT32): IB (x0.001A) +4 (INT32): IC (x0.001A) +6 (INT32): UAB (x0.01V) +8 (INT32): UBC (x0.01V) +10 (INT32): UCA (x0.01V) +12 (INT32): 3I0 (x0.001A)
30	2	Contact protection act		Record Value: +0 (INT32): IA (x0.001A) +2 (INT32): IB (x0.001A) +4 (INT32): IC (x0.001A) +6 (INT32): UAB (x0.01V) +8 (INT32): UBC (x0.01V) +10 (INT32): UCA (x0.01V) +12 (INT32): 3I0 (x0.001A)
31	2	Long start protection act		
32	2	Thermal overload protection act		
33	2	Jam protection act		
34	2	Ground fault protection act		Record Value: +0 (INT32): 3I0 (x0.001A) +2 (INT32): IA (x0.001A) +4 (INT32): IB (x0.001A) +6 (INT32): IC (x0.001A) +8 (INT32): UAB (x0.01V) +10 (INT32): UBC (x0.01V) +12 (INT32): UCA (x0.01V)
35	2	Phase current loss act		Record Value: +0 (INT32): IA (x0.001A) +2 (INT32): IB (x0.001A) +4 (INT32): IC (x0.001A) +6 (INT32): UAB (x0.01V) +8 (INT32): UBC (x0.01V) +10 (INT32): UCA (x0.01V) +12 (INT32): 3I0 (x0.001A)
36	2	Imbalance protection act		Record Value: +0 (INT32): Imbalance (x0.01%) +2 (INT32): IA (x0.001A) +4 (INT32): IB (x0.001A) +6 (INT32): IC (x0.001A) +8 (INT32): UAB (x0.01V) +10 (INT32): UBC (x0.01V) +12 (INT32): UCA (x0.01V)
37	2	Under power protection act		Record Value: +0 (INT32): kW total (W) +2 (INT32): IA (x0.001A) +4 (INT32): IB (x0.001A) +6 (INT32): IC (x0.001A) +8 (INT32): UAB (x0.01V) +10 (INT32): UBC (x0.01V) +12 (INT32): UCA (x0.01V)
38	2	Short circuit protection act		Record Value: +0 (INT32): IA (x0.001A)

				+2 (INT32): IB (x0.001A) +4 (INT32): IC (x0.001A) +6 (INT32): UAB (x0.01V) +8 (INT32): UBC (x0.01V) +10 (INT32): UCA (x0.01V) +12 (INT32): 3I0 (x0.001A)
39	2	Undervoltage protection act		Record Value: +0 (INT32): UAB (x0.01V) +2 (INT32): UBC (x0.01V) +4 (INT32): UCA (x0.01V) +6 (INT32): IA (x0.001A) +8 (INT32): IB (x0.001A) +10 (INT32): IC (x0.001A) +12 (INT32): 3I0 (x0.001A)
40	2	Oversvoltage protection act		
41	2	Underload protection act		Record Value: +0 (INT32): IA (x0.001A)
42	2	tE time protection act		+2 (INT32): IB (x0.001A)
43	2	Overload protection act		+4 (INT32): IC (x0.001A) +6 (INT32): UAB (x0.01V) +8 (INT32): UBC (x0.01V) +10 (INT32): UCA (x0.01V) +12 (INT32): 3I0 (x0.001A)
44	2	Interlock protection act		
45	2	LOP alarm		Record Value: +0 (INT32): UAB (x0.01V) +2 (INT32): UBC (x0.01V) +4 (INT32): UCA (x0.01V) +6 (INT32): IA (x0.001A) +8 (INT32): IB (x0.001A) +10 (INT32): IC (x0.001A) +12 (INT32): 3I0 (x0.001A)
46	2	Phase reversal protection act		Record Value: +0 (INT32): 3I0 (x0.001A) +2 (INT32): IA (x0.001A) +4 (INT32): IB (x0.001A) +6 (INT32): IC (x0.001A) +8 (INT32): UAB (x0.01V) +10 (INT32): UBC (x0.01V) +12 (INT32): UCA (x0.01V)
47	2	Closed-loop Abnormal protection act		Record Value: +0 (INT32): IA (x0.001A) +2 (INT32): IB (x0.001A) +4 (INT32): IC (x0.001A) +6 (INT32): UAB (x0.01V) +8 (INT32): UBC (x0.01V) +10 (INT32): UCA (x0.01V) +12 (INT32): 3I0 (x0.001A)
48	2	Contactoer abnormal protection act		Record Value: +0 (INT32): IA (x0.001A) +2 (INT32): IB (x0.001A) +4 (INT32): IC (x0.001A) +6 (INT32): UAB (x0.01V) +8 (INT32): UBC (x0.01V) +10 (INT32): UCA (x0.01V) +12 (INT32): Reserved
49	2	Emergency stop alarm		Record Value: +0 (INT32): IA (x0.001A) +2 (INT32): IB (x0.001A) +4 (INT32): IC (x0.001A) +6 (INT32): UAB (x0.01V) +8 (INT32): UBC (x0.01V) +10 (INT32): UCA (x0.01V) +12 (INT32): 3I0 (x0.001A)
50	2	MTA failure alarm		Record Value: +0 (BITMAP): Bit0: Phase A, Bit1: Phase B, Bit2: Phase C 0=Normal, 1=Abnormal +2 (INT32): IA (x0.001A) +4 (INT32): IB (x0.001A) +6 (INT32): IC (x0.001A) +8 (INT32): UAB (x0.01V) +10 (INT32): UBC (x0.01V) +12 (INT32): UCA (x0.01V)

51	2	Contactors failure protection act	Record Value: +0 (INT32): IA (x0.001A) +2 (INT32): IB (x0.001A) +4 (INT32): IC (x0.001A) +6 (INT32): UAB (x0.01V) +8 (INT32): UBC (x0.01V) +10 (INT32): UCA (x0.01V) +12 (INT32): 3I0 (x0.001A)
52	2	ACB trip contactor	
53	2	Residual current level I protection act	Record Value: +0 (INT32): IR (x0.001A) +2 (INT32): IA (x0.001A) +4 (INT32): IB (x0.001A) +6 (INT32): IC (x0.001A) +8 (INT32): UAB (x0.01V) +10 (INT32): UBC (x0.01V) +12 (INT32): UCA (x0.01V)
54	2	Residual current level II protection act	
55	2	Negative sequence protection act	Record Value: +0 (INT32): I2 (x0.001A) +2 (INT32): IA (x0.001A) +4 (INT32): IB (x0.001A) +6 (INT32): IC (x0.001A) +8 (INT32): UAB (x0.01V) +10 (INT32): UBC (x0.01V) +12 (INT32): UCA (x0.01V)
56	2	Thermo protection act	Record Value:
57	2	Thermo short cct. alarm	+0 (INT32): R (x0.001kΩ) +2 (INT32): IA (x0.001A) +4 (INT32): IB (x0.001A) +6 (INT32): IC (x0.001A) +8 (INT32): UAB (x0.01V) +10 (INT32): UBC (x0.01V) +12 (INT32): UCA (x0.01V)
58	2	Thermo open cct. alarm	
59	2	TC1 level I protection act	(INT32): TC1 (x0.1°C)
60	2	TC1 level II protection act	
61	2	TC2 level I protection act	(INT32): TC2 (x0.1°C)
62	2	TC2 level II protection act	
63	2	TC3 level I protection act	(INT32): TC3 (x0.1°C)
64	2	TC3 level II protection act	
65	2	TC4 level I protection act	(INT32): TC4 (x0.1°C)
66	2	TC4 level II protection act	
67	2	TC5 level I protection act	(INT32): TC5 (x0.1°C)
68	2	TC5 level II protection act	
69	2	TC6 level I protection act	(INT32): TC6 (x0.1°C)
70	2	TC6 level II protection act	
71	1/2	TC1 sensor is restored/abnormal	--
72	1/2	TC2 sensor is restored/abnormal	--
73	1/2	TC3 sensor is restored/abnormal	--
74	1/2	TC4 sensor is restored/abnormal	--
75	1/2	TC5 sensor is restored/abnormal	--
76	1/2	TC6 sensor is restored/abnormal	--
77	1/2	Insulation protection act	Record Value: +0 (INT32): R (x0.001kΩ) +2 (INT32): IA (x0.001A) +4 (INT32): IB (x0.001A) +6 (INT32): IC (x0.001A) +8 (INT32): UAB (x0.01V) +10 (INT32): UBC (x0.01V) +12 (INT32): UCA (x0.01V)
78	1/2	Thermal Overload Alert	Record Value: +0 (INT32): IA (x0.001A) +2 (INT32): IB (x0.001A) +4 (INT32): IC (x0.001A) +6 (INT32): I1 (x0.001A) +8 (INT32): I2 (x0.001A) +10 (INT32): 3I0 (x0.001A) +12 (INT32): Ieq (x0.001A)
100	2	PLC1 trip	Record Value:
101	2	PLC2 trip	+0 (INT32): IA (x0.001A) +2 (INT32): IB (x0.001A) +4 (INT32): IC (x0.001A)
102	2	PLC3 trip	
103	2	PLC1 alarm	+4 (INT32): IC (x0.001A) +6 (INT32): UAB (x0.01V)
104	2	PLC2 alarm	

	105	2	PLC3 alarm	+8 (INT32): UBC (x0.01V) +10 (INT32): UCA (x0.01V) +12 (INT32): 3I0 (x0.001A)
	106	2	PLC1 trip ACB	
	107	2	PLC2 trip ACB	
	108	2	PLC3 trip ACB	
	109	2	PLC Event 1	
	110	2	PLC event 2	
	111	2	PLC event 3	
	112	2	Limit Position Abnormality	
	113	2	Dual Limit Fault	
	114	2	Motorized Valve Stall	
	115	2	Dual Over Torque Fault	
	116	2	Motorized Valve Control Timeout	
	250	2	Manual trigger WFR	
	251	2	PLC trigger WFR	
3=Operation Log	1	--	Power off	
	2	--	Power on	
	3	--	Clear SOE and Protection log	
	4	--	Clear Energy	
	5	--	Clear Statistics	
	6	--	Clear Start Report	
	7	--	Clear Stop Report	
	8	--	Clear Waveform Recorder	
	9	--	Reserved	
	10	--	Clear Insulation Log	
	11	--	Reset Protection via HMI module	
	12	--	Reset Protection via comm.	
	13	--	Preset Energy	
	14	--	Change Date/Time	
	15	--	Change Password	
	16	--	Restore Device Parameters	
	17	--	Calibration Reset	
	18	--	Factory Reset	
	19	--	Set System Parameters	
	20	--	Set DI Parameters	
	21	--	Set DO Parameters	
	22	--	Set Communication Parameters	
	23	--	Set Protection Parameters	
	24	--	Set Control Parameters	
	25	--	Set AO Parameters	
	26	--	Reserved	
	27	--	Set Insulation Test Parameters	
	28	1/2	Enter/Exit Comm. Test	
	29	1/2	Enter/Exit Logic Test	
	30	--	Trigger WFR Remotely	
	31	--	Manual Trigger WFR via HMI	
4=Diagnostic Log	1	--	First power-up	
	2	--	Metering Error	UINT32: Ho – DC bias voltage (x0.001V) Lo – error channel (1=abnormal, 0=normal) BIT16: UAB, BIT17: UBC, BIT18: IA BIT19: IB, BIT20: IC, BIT21: IR
	3	--	Device Parameter Error	
	4	--	Factory Parameter Error	
	5	--	FRAM Error	
	6	--	FLASH Error	

Appendix B – Ordering Guide

 Version 20250730	
Product Code	Description
PMC-550D	Low-voltage Motor Protection and Control Device with a Remote Display module, 1xResidual Current Input and 1xNTC/PTC Input (for Thermo Resistance Calculation)
Language	
E	English
Input Voltage	
6	400VLN/690VLL
Power Supply	
A	95-250V AC/DC ± 10%, with 30 seconds of ride through
System Frequency	
5	50Hz
6	60Hz
DI/DO	
A~	10xDI (Dry Contact), 5xDO
B	10xDI (220VAC/DC), 5xDO
AO	
A	1xAnalog Output (4-20mA DC)
Communications	
B	2xRS-485 Port
C*	1xPROFIBUS DP Port (Either DB9 terminal or 3 Position Terminal Block) + 1xRS-485 Port (Modbus RTU)
D*	1xPROFIBUS DP Port (Either DB9 terminal or 3 Position Terminal Block) + 1xRS-485 Port (Either Modbus RTU or PROFIBUS DP)
E*	2x10/100BaseT Ethernet Port + 1xRS-485 Port
F*	2xPROFINet over Ethernet Port + 1xRS-485 Port
DO2 Type	
A	Normally Open
B	Normally Closed
HMI	
B	Standard Display Module
H*	Color LCD Module
PMC-550D - E 6 A 5 A A B A - B	PMC-550D-E6A5AABA-B (Standard Model)

*Additional charges apply

- The 3-phase Current Input requires an external MTA Current Transducer. Refer to the MTA Current Transducers sheet for detailed information.
 - I Residual Protection requires an external I Residual CT. Refer to the MIR Current Transducers for detailed information.
 - For the I/O options, default by following:
 - DO1=Normally Closed, DO2-5=Normally Open;
 - AO with Internal 24VDC Power Supply.
 - Optionally, the PMC-550D can be equipped with a PMC-KT module featuring 6xNTC Input, 1xDO (Form C) and 2xDI (Dry Contact). Detailed information is available in the Expansion Modules and NTC Thermistor sheets.
 - Optionally, the PMC-550D can be equipped with a PMC-KR module for insulation monitoring. Refer to the Expansion Modules sheet for more information.
- ~ For the DI/DO 'Option A', the Dry Contact DI can be used with the PMC-KI module to convert 110V/220V excitation voltage to Dry Contact Output. Refer to the Expansion Modules sheet for further details.

Appendix C – Technical Specification

Voltage Inputs (VA, VB, VC)		
Standard (Ue)	240VLN/415VLL	
Range (ULL)	10V to 828V	
Overload	1.2xVn continuous, 2.0xVn for 10s	
Burden	<0.75VA per phase	
Measurement Category	CAT III 300VLL	
Frequency	50Hz/60Hz	
Current Inputs		
Plug-in Current Sensor PMC-MTAs (IA, IB, IC, IN)		
Ie	1A/5A/25A/100A/300A/400A/800A	
Range	5% to 120% Ie	
Overload	2xIe continuous, 10xIe for 10s, 40xIe for 1s	
Burden	<0.05VA per phase @5A Input	
Residual Current Sensor PMC-MIR (-IR, IR)		
Primary (In)	1A	
Secondary	1V	
I _{max}	5In continually	
Power Supply (L/+, N/-)		
Standard	95-250VAC/DC with Enhanced power supply (ride-through capability)	
Burden	<6W	
Overvoltage Category	OVC III 300VLN	
Digital Inputs (DIC, DI1, DI2, DI3, DI4, DI5, DI6, DI7, DI8, DI9, DI10)		
Standard	Internally wetted (dry contact) with 24VDC	
Optional	Externally wetted with 220VAC/DC	
Debounce Time	20~9999ms programmable	
Relay Outputs (DO11, DO12, DO21, DO22, DO31, DO32, DO41, DO42, DO51, DO52)		
Type	DO1 Form B (NC), DO2 Form A (NO) or Form B (NC), DO3 to DO5 Form A (NO)	
	DO1 to DO4	DO5
Contact Rating	250VAC/24VDC, 8A	250VAC/30VDC, 5A
Max. Switching Voltage	400VAC/30VDC	277VAC/30VDC
Max. Carrying Current	10A	5A
Max. Switching Power	2000VA/192W	1250VA/150W
Operate Time	<10ms	<10ms
Release Time	<5ms	<10ms
Service Life	>20,000,000 cycles (Mechanical) >100,000 cycles (Electrical at rated load)	>5,000,000 cycles (Mechanical) >100,000 cycles (Electrical at rated load)
Internal Clearance/Creepage	>8mm (Safety Insulation up to 250VAC) (EN61810-1, Pollution Degree 3)	>6mm (Safety Insulation up to 250VAC) (EN61810-1, Pollution Degree 2)
Analog Output (AO+, AO-)		
Load	750 ohms	
Range	4 to 20 mA	
Thermo Input (TC11, TC12)		
Type	PTC or NTC	
Range	0.03kΩ to 32.00kΩ	
Terminals Max. Torque		
Power Supply, DI, DO, IR, TC, AO, DP, RS-485	0.49N.m / 5 kgf.cm / M3 / 4.34 lb-in	
Environmental Conditions		
Operating Temperature	-25°C to 70°C	
Storage Temperature	-40°C to 85°C	
Humidity	5% to 95% non-condensing	
Atmospheric Pressure	70kPa to 106kPa	
Mechanical Characteristics		
HMI Module Panel Cutout	44.0x65.0 mm	
Unit Dimensions	108.0x95.0x122.5 mm	
IP Rating	40	

PMC-550D-HMI Module	
Display (Power and Communications)	
Power	Max. 60mA, 5VDC
Interface	RJ45
Data Transmission	RS-232
Optional PMC-KT Expansion Module	
Expansion (Power and Communications)	
Power	Max. 70mA, 5VDC
Interface	RJ45
Data Transmission	RS-485
Digital Input (DI1, DI2)	
Standard	Dry contact, internally wetted with 24VDC
Debounce Time	20~9999ms programmable
TC Input (TC11, TC12, TC21, TC22, TC31, TC32, TC41, TC42, TC51, TC52, TC61, TC62)	
Type	NTC
Range	0 to 150 °C
Digital Output (DO61, DO62, DO63)	
Type	Form C Mechanical Relay
Contact Rating	250VAC/30VDC, 5A
Max. Switching Voltage	277VAC/30VDC
Max. Carrying Current	5A
Max. Switching Power	1250VA/150W
Operate Time	<10ms
Release Time	<10ms
Service Life	>5,000,000 cycles (Mechanical) >100,000 cycles (Electrical at rated load)
Internal Clearance/Creepage	(EN61810-1, Pollution Degree 2)
Optional PMC-KR Expansion Module	
Power Supply (L/+, N/-)	
Standard	95-250VAC/DC
Burden	<3W
Insulation Resistance Test (V, G)	
Test Voltage	550VDC / 1000VDC
Resistance Range	100kΩ to 100MΩ
Expansion	
Data Transmission	RS-485
Optional PMC-KI Converter Module	
Voltage Input (1, 2, 3, 4)	
Rated Voltage	110VAC/DC or 220VAC/DC
Rated Current	0.45mA (for 110VAC/DC input) or 0.21mA (for 220VAC/DC input)
Output (5, 6, 7, 8)	
Max. Forward Voltage	40V
Max. Forward Current	50mA

Appendix D – Accuracy Specification

Parameters	Accuracy	Resolution
Voltage (U)	±0.5%	0.001V
IA, IB, IC	±0.5%	0.001A
IR	20mA to 1200mA: ±1.0%	1mA
	1200mA to 5000mA: ±3.0%	
kW, kvar, kVA	±1.0%	0.001kx
kWh	±1.0%	0.01kWh
kvarh	+2.0%	0.01kvarh
Power Factor	±1.0%	0.001
Frequency	±0.02Hz	0.001Hz
Analog Output	±0.5%	--
Harmonics	IEC 61000-4-7 Class II	0.01%
Insulation Resistance	±0.5%	0.1MΩ
Thermal Resistance	1% or 10Ω	0.01Ω
NTC Input	0 to 80 °C: ±1.0°C	0.1°C
	80 to 150 °C: ±2.0°C	

Appendix E – Relay Elements Specifications

Thermal Overload Stage: Off, Alarm, Trip, Trip & Alarm Iov Setting Range: 1.00 - 10.00 x Ie Tc Setting Range: 0.10 - 99.99 seconds Alert Threshold: Off, 0 - 99% x Heat Capacity Return Threshold: 0 - 100% Accuracy: (≤ 3 seconds) ± 100 ms (> 3 seconds) $\pm 5\%$ of pickup	Long Start Stage: Off, Alarm, Trip, Trip & Alarm Time Dial: 0.10 - 99.99 seconds Accuracy: (≤ 3 seconds) ± 60 ms (> 3 seconds) $\pm 2\%$ of pickup
Jam Stage: Off, Alarm, Trip, Trip & Alarm Setting Range: 1.00 - 10.00 x Ie Accuracy: ± 50 mA or $\pm 3\%$ of pickup Time Dial: 0.10 - 99.99 seconds Accuracy: (≤ 3 seconds) ± 60 ms (> 3 seconds) $\pm 2\%$ of pickup	Ground Fault Stage: Off, Alarm, Trip, Trip & Alarm Setting Range: 0.10 - 10.00 x Ie Accuracy: ± 50 mA or $\pm 3\%$ of pickup Time Dial: (Start State) 0 - 99.99 seconds (Run State) 0 - 99.99 seconds Accuracy: (≤ 3 seconds) ± 60 ms (> 3 seconds) $\pm 2\%$ of pickup
MTA Failure Stage: Off, Alarm Time Dial: 0.10 - 99.99 seconds Accuracy: (≤ 3 seconds) ± 60 ms (> 3 seconds) $\pm 2\%$ of pickup	Phase Current Loss Stage: Off, Alarm, Trip, Trip & Alarm Time Dial: 0.10 - 99.99 seconds Accuracy: (≤ 3 seconds) ± 60 ms (> 3 seconds) $\pm 2\%$ of pickup
Imbalance Stage: Off, Alarm, Trip, Trip & Alarm Setting Range: 10% - 100% Accuracy: $\pm 3\%$ of pickup Time Dial: 0.10 - 99.99 seconds Accuracy: (≤ 3 seconds) ± 60 ms (> 3 seconds) $\pm 2\%$ of pickup	Under Power Stage: Off, Alarm, Trip, Trip & Alarm Setting Range: -999.9 - 999.9 kW Accuracy: $\pm 5\%$ of pickup Time Dial: 0.50 - 99.99 seconds Accuracy: (≤ 3 seconds) ± 60 ms (> 3 seconds) $\pm 2\%$ of pickup
Short Circuit Stage: Off, Alarm, Trip, Trip & Alarm Setting Range: 1.00 - 10.00 x Ie Start Multiple: 1.00 - 2.00 Accuracy: ± 50 mA or $\pm 3\%$ of pickup Time Dial: 0 - 99.99 seconds	Undervoltage Stage: Off, Alarm, Trip, Trip & Alarm Setting Range: 0.30 - 0.95 x Ue Accuracy: ± 2 V or $\pm 3\%$ of pickup Time Dial: 0.10 - 99.99 seconds Accuracy: (≤ 3 seconds) ± 60 ms (> 3 seconds) $\pm 2\%$ of pickup
Overvoltage Stage: Off, Alarm, Trip, Trip & Alarm Setting Range: 1.05 – 1.60 x Ue Accuracy: ± 2 V or $\pm 3\%$ of pickup Time Dial: 0.10 – 99.99 seconds Accuracy: (≤ 3 seconds) ± 60 ms (> 3 seconds) $\pm 2\%$ of pickup	Underload Stage: Off, Alarm, Trip, Trip & Alarm Setting Range: 0.10 – 1.00 x Ie Accuracy: ± 50 mA or $\pm 3\%$ of pickup Time Dial: 1 – 9999 seconds Accuracy: (≤ 3 seconds) ± 60 ms (> 3 seconds) $\pm 2\%$ of pickup
tE Time Stage: Off, Alarm, Trip, Trip & Alarm Tp Setting Range: 0.01 – 99.99 seconds Accuracy: (≤ 3 seconds) ± 100 ms (> 3 seconds) $\pm 5\%$ of pickup	Overload Stage: Off, Alarm, Trip, Trip & Alarm Setting Range: 1.00 – 10.00 x Ie Accuracy: ± 50 mA or $\pm 3\%$ of pickup Time Dial: 0.10 – 99.99 seconds Accuracy: (≤ 3 seconds) ± 60 ms (> 3 seconds) $\pm 2\%$ of pickup
Interlock Stage: Off, Alarm, Trip, Trip & Alarm Time Dial: 0 – 99.99 seconds Accuracy: (≤ 3 seconds) ± 60 ms (> 3 seconds) $\pm 2\%$ of pickup	Closed-loop Abnormal Stage: Off, Alarm, Trip, Trip & Alarm Time Dial: 0.10 – 5.00 seconds Accuracy: (≤ 3 seconds) ± 60 ms (> 3 seconds) $\pm 2\%$ of pickup

LOP	Phase Reversal
Stage: Off, Alarm	Stage: Off, Alarm, Trip, Trip & Alarm
Contactors Protection	Contactors Failure
Stage: Off, On Setting Range: 4.0 – 20.0 x I _e Accuracy: ±50mA or ±3% of pickup	Stage: Off, On Setting Range: 0.10 – 5.00 x I _e Accuracy: ±50mA or ±3% of pickup Time Dial: 0.10 – 99.99 seconds Accuracy: (≤ 3 seconds) ±60ms (> 3 seconds) ±2% of pickup
ACB Trip Contactors	Contactors Abnormal
Stage: Off, On Time Dial: 0.10 – 99.99 seconds Accuracy: (≤ 3 seconds) ±60ms (> 3 seconds) ±2% of pickup	Stage: Off, Alarm, Trip, Trip & Alarm Time Dial: 0.10 – 99.99 seconds Accuracy: (≤ 3 seconds) ±60ms (> 3 seconds) ±2% of pickup
Residual Current	Negative Sequence
Stage: Off, Alarm, Trip, Trip & Alarm Setting Range: 20.0 – 5000.0 mA Accuracy: ±50mA or ±3% of pickup Time Dial: 0.00 – 99.99 seconds (Trip) 0.0 – 99.9 seconds Accuracy: (≤ 3 seconds) ±60ms (> 3 seconds) ±2% of pickup	Stage: Off, Alarm, Trip, Trip & Alarm Setting Range: 0.10 – 10.00 x I _e Accuracy: ±50mA or ±3% of pickup Time Dial: 0.10 – 99.99 seconds Accuracy: (≤ 3 seconds) ±60ms (> 3 seconds) ±2% of pickup
Thermo	Insulation Resistance
Stage: Off, Alarm, Trip, Trip & Alarm Setting Range: 0.10 – 30.00 kΩ Accuracy: ±3% of pickup Time Dial: 0.10 – 99.99 seconds Accuracy: (≤ 3 seconds) ±60ms (> 3 seconds) ±2% of pickup	Stage: Off, Alarm, Trip, Trip & Alarm Setting Range: 0.1 – 50.0 MΩ Accuracy: ±3% of pickup
Overtemperature	Emergency Stop Alarm
Stage: Off, Alarm, Trip, Trip & Alarm Setting Range: 20.0 – 150.0 °C Accuracy: ±3% of pickup Time Dial: 0.00 – 99.99 seconds Accuracy: (≤ 3 seconds) ±60ms (> 3 seconds) ±2% of pickup	Stage: On, Off

Appendix F – Standard of Compliance

Safety Requirements	
CE LVD 2014 / 35 / EU	EN 61010-1: 2010 + A1: 2019 EN IEC 61010-2-030: 2021
Insulation AC Voltage: 2kV @ 1 minute Insulation Resistance: > 100MΩ Impulse Voltage: 5kV, 1.2/50us	IEC 60255-5: 2000 EN 61010-1:2010+A1:2019 EN IEC 61010-2-030:2021
EMC Compatibility CE EMC Directive 2014 / 30 / EU (EN IEC 61326: 2021)	
Immunity Test	
Electrostatic Discharge	EN 61000-4-2: 2009
Radiated Fields	EN 61000-4-3: 2020
Fast Transients	EN 61000-4-4: 2012
Surges	EN 61000-4-5: 2014 + A1: 2017
Conducted Disturbances	EN 61000-4-6: 2014
Power Frequency Magnetic Fields	EN 61000-4-8: 2010
Pulsed Magnetic Fields	EN 61000-4-9: 2016
Damped Oscillatory Magnetic Fields	EN 61000-4-10: 2017
Voltage Dips and Interruptions	EN IEC 61000-4-11: 2020
Ripple on DC Input Power Port	EN 61000-4-17: 1999 + A2: 2009
Damped Oscillatory Wave	EN IEC 61000-4-18: 2019
Power Frequency Immunity on Binary Inputs	IEC 60255-26: 2013 Class A
Gradual Shut Down / Start-up Tests	IEC 60255-26: 2013
Emission Test	
Limits and Methods of Measurement of Electromagnetic Disturbance Characteristics of Industrial, Scientific and Medical (ISM) Radio-Frequency Equipment	EN 55011: 2016 + A1: 2017 + A2: 2021
Electromagnetic Compatibility of Multimedia Equipment - Emission Requirements	EN 55032: 2015 + AC: 2016 + A11: 2020
Limits for Harmonic Current Emissions for Equipment with Rated Current ≤ 16 A	EN IEC 61000-3-2: 2019 + A1: 2021
Limitation of Voltage Fluctuations and Flicker in Low-Voltage Supply Systems for Equipment with Rated Current ≤ 16 A	EN 61000-3-3: 2013 + A1: 2019 + A2: 2021
Emission Standard for Industrial Environments	EN IEC 61000-6-4: 2019
Mechanical Test	
Vibration Test (Response/Endurance)	IEC 60255-21-1: 1988 Level I
Shock Test (Response/Endurance)	IEC 60255-21-2 Level II
Bump Test (Response Endurance)	IEC 60255-21-2 Level I

Contact us

CET Electric Technology Inc.

Email: support@cet-global.com

Web: www.cet-global.com